

J U L Y 1 9 2 9

Desk

# BROADCAST

PUBLISHED FOR THE RADIO INDUSTRY



The A. C. vs. the Battery Set—A Sales Comparison

New Ideas on Retailing Radio

How One Dealer Solved the Trade-In Problem

Other Features: The 245-Type Tube · Measuring Loud Speakers · Engineering Descriptions of  
Sley, Fada, and Silver Sets · The Future of the A.C. Screen-Grid Tube · The Experimenter's Armchair.

T H I R T Y F I V E C E N T S

PUBLISHED BY DORAN & CO., INC. ♦ GARDEN CITY, NEW YORK

# TRIAD

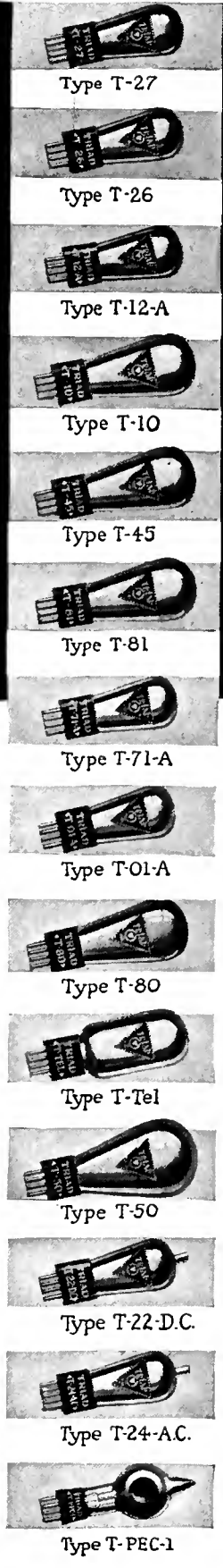

**INSTANT... nation-wide popularity**  
**...won on quality alone!**

**T**HE demand for TRIAD is sweeping along to tremendous proportions—and TRIAD quality has done it! Quality that eliminates all guesswork from tube buying and selling; quality backed by an actual bonafide guarantee of six month's perfect service or a satisfactory adjustment. Every dealer *knows* what that means—*reduced service calls*, easier and quicker sales, greater profits and

absolute satisfaction for him and his customer. Here is the greatest achievement in radio tube history—accomplished by a group of nationally-known pioneers in the industry. The TRIAD Line is complete, including even Television and Photo-Electric Cells. Don't delay—send in your stock order *now*. TRIAD customers won't accept substitutes.

*Call your jobber or write us direct for complete Triad dealer information*

**TRIAD MANUFACTURING CO., INC.**

Triad Building  
 Blackstone, Middle and Fountain Sts.  
 Pawtucket, R. I.





# A MARVELOUS **NEW** IMPROVEMENT IN RADIO TUBES

## EVEREADY RAYTHEON TUBES

### GIVE A SUPERLATIVE DEGREE OF PERFORMANCE

INSTALL a set of new Eveready Raytheon Tubes in your radio receiver and note the unusually clear reception, greater volume and sensitivity. Quick heating and quick acting.

Behind all this is a revolutionary improvement in construction. The elements in each Eveready Raytheon Tube are firmly supported by *four strong pillars*, cross-anchored top and bottom. They are accurately spaced within one-thousandth of an inch when they are made. And so rigidly braced that the spacing cannot change with the knocks and jolts of shipment and handling.

In tubes of the 280 type and the 224 screen-grid type, which have heavier elements, this rugged Eveready Raytheon *4-Pillar construction* is of particular importance.

Only with Eveready Raytheon Tubes can you have this improved construction advantage. It is exclusive and patented. Eveready Raytheon Tubes come in every type, including tubes for television transmission and reception.

Eveready Raytheon Tubes are sold by dealers everywhere.

NATIONAL CARBON CO., INC.  
New York, N. Y.

Unit of  and Carbon Corporation



Showing the exclusive patented Eveready Raytheon 4-Pillar construction. Note the sturdy four-cornered glass stem through which the four heavy wire supports pass, and the rigid mica sheet at the top.



Eveready Raytheon ER 224 Screen Grid Tube. The 4-Pillar construction permanently holds the four heavy elements of this super-sensitive tube in the perfect relation which assures laboratory performance.



# SPECIAL TEST EQUIPMENT

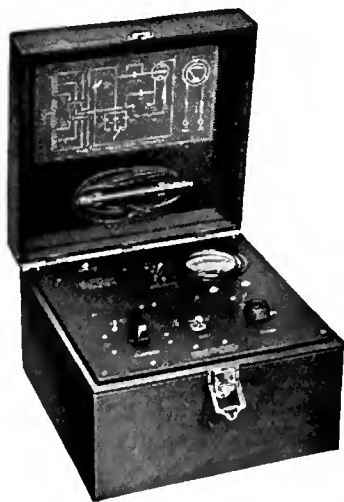

for use in the service laboratory is soon to be announced. This will include an oscillator for measuring the over-all response characteristics of a receiver for the entire broadcast band. It will be inexpensive, compact, and of General Radio quality.

Write for Bulletin G-1

## GENERAL RADIO COMPANY

30 State Street  
Cambridge, Massachusetts

274 Brannan Street  
San Francisco, California



### MODEL 489 D. C. PORTABLE THREE-RANGE VOLTMETER

750 - 250 - 10 Volts  
1000 Ohms per Volt Resistance

A STURDY, miniature instrument, suitable for home or laboratory use—popular because of its small size and unusual electrical characteristics. A truly professional instrument, with all the niceties of design and construction which make a "Weston" so desirable.

Solid black bakelite case, convenient pin jacks, and test cables equipped with pin terminals for insertion in the jacks. Reasonably priced.

Weston Electrical Instrument Corp.  
604 Frelinghuysen Ave., Newark, N. J.

# WESTON RADIO INSTRUMENTS

## WHY POLYMET-EQUIPPED RADIOS ARE WORTH MORE



Here are some of the advertisements we have been running in the Saturday Evening Post—interesting, instructive messages, that acquaint the non-technical public with the functions of the condensers and resistances we manufacture, and, at the same time, awaken a nation-wide consumer acceptance of, and preference for, sets equipped with well-known Polymet Products. That's why these sets are worth more to radio manufacturer, jobber and dealer.

**POLYMET MFG. CORPORATION**  
837 East 134th St. New York City  
**POLYMET PRODUCTS**

Jensen Patents allowed and pending. Licensed under Lektophone Patents

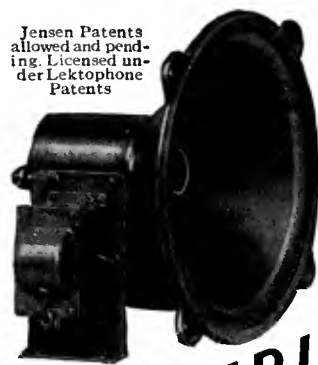

# ANSWERING the demand of an INDUSTRY the new **Jensen** CONCERT DYNAMIC

Peter L. Jensen has applied entirely new and original principles in the design of this new dynamic. The cone is 10 inches in diameter. The moving coil represents an innovation in design. The sensitivity is greater than that ever attained in any previous dynamic speaker, and the ability to reproduce enormous volume is exceeded only by the Jensen Auditorium Dynamic.

The Concert Dynamic definitely sets a new standard of excellence. For along with the musical reproduction of bass notes as low as 30 cycles, the higher frequencies are reproduced with extraordinary brilliance. In fact the entire musical scale is reproduced with a brilliance and firmness of quality never acquired before.

There is no need of a "side by side" comparison to appreciate the superiority of this new speaker. Wherever it is heard its performance is both startling and impressive.

Write for complete information and ask for a frequency response curve of this new speaker if you are interested. Ask also about the new Jensen Imperial, a beautiful cabinet equipped with either the Concert or Auditorium Unit.

## NEW LOW PRICES

JENSEN CONCERT DYNAMIC  
with 10 inch cone  
D7AC, \$35.00 D7DC, \$27.50

JENSEN AUDITORIUM DYNAMIC  
with 12 inch cone  
DA5AC, \$70.00 DA5, \$55.00 DA4, \$55.00

JENSEN PATENTS ALLOWED AND PENDING  
LICENSED UNDER LEKTOPHONE PATENTS

JENSEN RADIO MFG. CO.  
6601 S. Laramie Ave., Chicago, Ill.  
212 Ninth St., Oakland, Calif.

The Oldest  
 Manufacturer of  
**SCREEN-GRID**  
 Receivers  
 Presents



# SILVER

McMurdo Silver..  
 Designer and Builder  
 of **SCREEN-GRID**  
 RADIO Since 1927

# RADIO

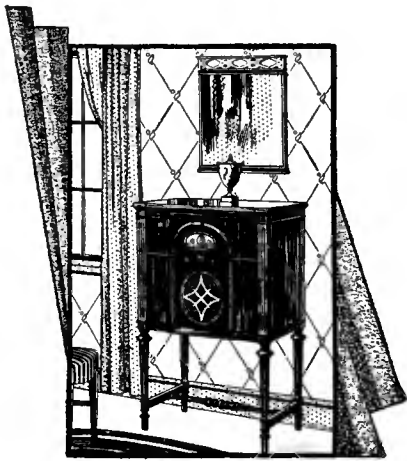

### Silver Radio Features

No aerial, no loop, no installation bother. 8-tube, all-electric. 4 screen-grid tubes; two 245 power tubes in push-pull. Screen-grid power detector. Matched impedance dynamic speaker. Overtone switch for static reduction. **\$160**  
 Sheraton Lowboy, walnut finish as illustrated, *Less tubes*

Also sliding-door Highboy, \$195  
 (Prices slightly higher west of the Rockies)

—the direct descendant of those custom-built screen-grid radios of last season whose remarkable performance has been primarily responsible for the present sharp trend toward the screen-grid principle.

—Silver Radio is the only screen-grid receiver which has back of it 25,000 successful screen-grid sets, and nearly two years of screen-grid manufacturing experience.

—at the R.M.A. Show in Chicago, screen-grid receivers predominated. This proves our prediction that "1929 will be a screen-grid year."

—make it your business to HEAR Silver Radio. If you're a dealer, mail the coupon and we'll arrange it with your nearest distributor.

SILVER-MARSHALL, Inc.  
 6443 West 65th Street, Chicago, U. S. A.

Please ask our nearest distributor to arrange for a demonstration of SILVER RADIO.

Firm Name .....

Address .....

Individual .....

**SM**

Manufactured by  
**SILVER-MARSHALL, Inc.**

6443 West 65th Street

Chicago, Illinois, U. S. A.



# A Finer Screen-Grid Instrument

Browning & Millen Designed—NATIONAL Built

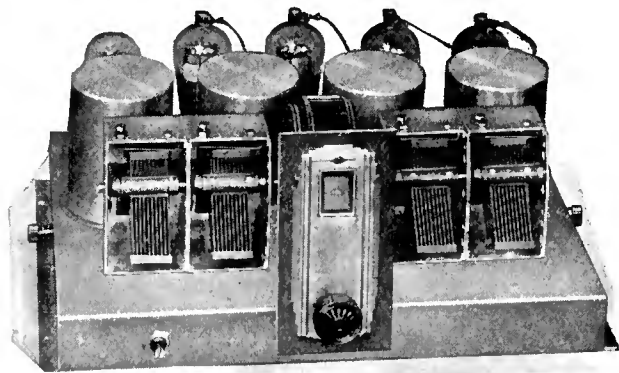

The MB-29 with its 4 A. C. Screen Grid Tubes and 227 detector, with its beautiful shielded aluminum chassis in frosted finish—with the Newest NATIONAL Weld-Built Condensers and the 1930 Model Velvet Vernier Projector Dial—offers the Large Scale Custom Set Builder, as well as the Radio owner and the Experimenter, a fine, engineered, R. F. Tuner of enormous gain and selectivity—ready for combination with power supply and audio—especially suited for consoles, and radio-phonograph combinations. Write for Bulletin BB-7, to-day.

The NATIONAL VELVETONE AMPLIFIER-POWER SUPPLY is especially designed for use with the NATIONAL MB-29

## NATIONAL

SCREEN-GRID MB-29 TUNER  
NATIONAL CO. INC., Malden, Mass.

Est. 1914

# Potter Condensers

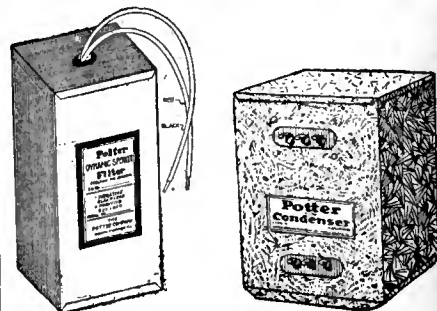

Potter Dynamic Speaker Filter .. \$4.75

### POTTER FILTER BLOCKS

- T-2900 Condenser Block for the single 250 type tube amplifier..... \$20.00
- T-2950 Condenser for the push-pull 250 type tube amplifier..... \$22.50
- T-2098 Condenser Block for single 210 type tube amplifier..... \$20.00
- T-280-171 Condenser Block for power pack with 280 type tube rectifier. \$18.00
- SM-673 Condenser Block for Silver-Marshall power amplifier and power supply units.... \$20.00
- RR-245 Condenser Block for single and push-pull 245 type tube amplifier. \$19.75

### The Potter Co.

North Chicago, Illinois

A National Organization at Your Service

A Good SUMMER SELLER!

**CORWICO VULCAN**  
Lightning Arrester



List \$1.00

The CORWICO VULCAN LIGHTNING ARRESTER not only protects a radio receiver against lightning but it also dissipates accumulated static charges. Corwico Vulcan is the best value lightning arrester on the market. It is big—it is colorful, an attractive dark green shade, and it is packed in an eye-catching, two-color box.

#### \$100 GUARANTEE

Inclosed in every box is a guarantee to repair up to a cost of \$100, any radio set protected by a CORWICO VULCAN LIGHTNING ARRESTER that is damaged by lightning. Stock this item now for quick sales and profits.

If Your Jobber Cannot Supply You, Order A Sample Direct.

**CORNISH WIRE COMPANY**  
30 Church Street, New York City

Makers of  
Corwico BRAIDITE Hook-Up Wire

The HAMMARLUND R. F. CHOKE COIL Is Better Built

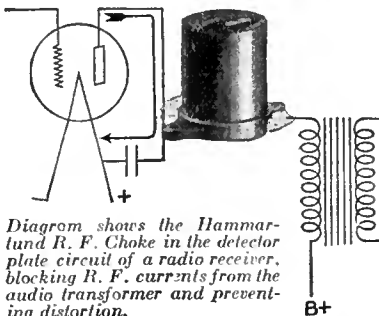

Diagram shows the Hammarlund R. F. Choke in the detector plate circuit of a radio receiver, blocking R. F. currents from the audio transformer and preventing distortion.

A specially developed method of winding and impregnating gives the Hammarlund R. F. Choke an extremely high impedance to all frequencies in the broadcast range. Having no pronounced natural period, its action is uniform throughout the broadcast frequencies.

Compact and completely shielded with a handsome Bakelite case. Current capacity, 60 milliamperes. Two sizes: 85 and 250 millihenries.

Write Dept. RB7 for special R. F. Choke data, showing important uses in modern receivers

HAMMARLUND MANUFACTURING CO.  
424-438 W. 33rd St., New York, N. Y.

For Better Radio  
**Hammarlund**  
PRECISION PRODUCTS

attention service men

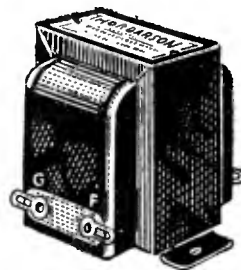

A quality replacement audio transformer for the service man. Possesses the same high degree of performance which characterizes all Thordarson audio units.

Provides highest amplification consistent with quality reproduction.

**Unique Mounting Feature**—The mounting bracket of this transformer is designed to fit all standard mountings without the necessity of drilling additional holes. May be mounted either on end or side or may be used as bracket to support sub-panel.

**Remember:** Thordarson radio transformers are Supreme in musical performance.

R-100 - - - List Price \$2.25

THORDARSON ELECTRIC MFG. CO.

Transformer Specialists Since 1895  
Huron, Kingslury & Larrabee Sts., Chicago

# THORDARSON

replacement audio transformer

# SM

## Is There No Limit To What an S-M Receiver Will Do?

### Australia to New York On Six Tubes

**M**ORE and more astounding are the records of long-distance reception with Silver-Marshall screen-grid receivers. First the S-M 710 (Sargent-Rayment Seven) made itself famous as the one set which, in California, could be relied on to bring in Japanese broadcasting stations in any kind of favorable conditions—and often when conditions were otherwise. Later, reports began to be published of reception across the Pacific with the S-M 720 Screen-Grid Six—using only three screen-grid r.f. stages instead of four. Then, in March, came the publication of verified reception in New York City, from 2BL at Sydney, with the 710.

And now the Australia-to-New York record has been duplicated with the 720 Screen-Grid Six.

Not every one, perhaps, has the necessary skill to bring in stations from half way around the globe—but the hard-to-please listener, wherever he may be, soon finds that screen-grid tubes, combined with Silver-Marshall engineering, are the ultimate answer to every demand for superlative radio reception.

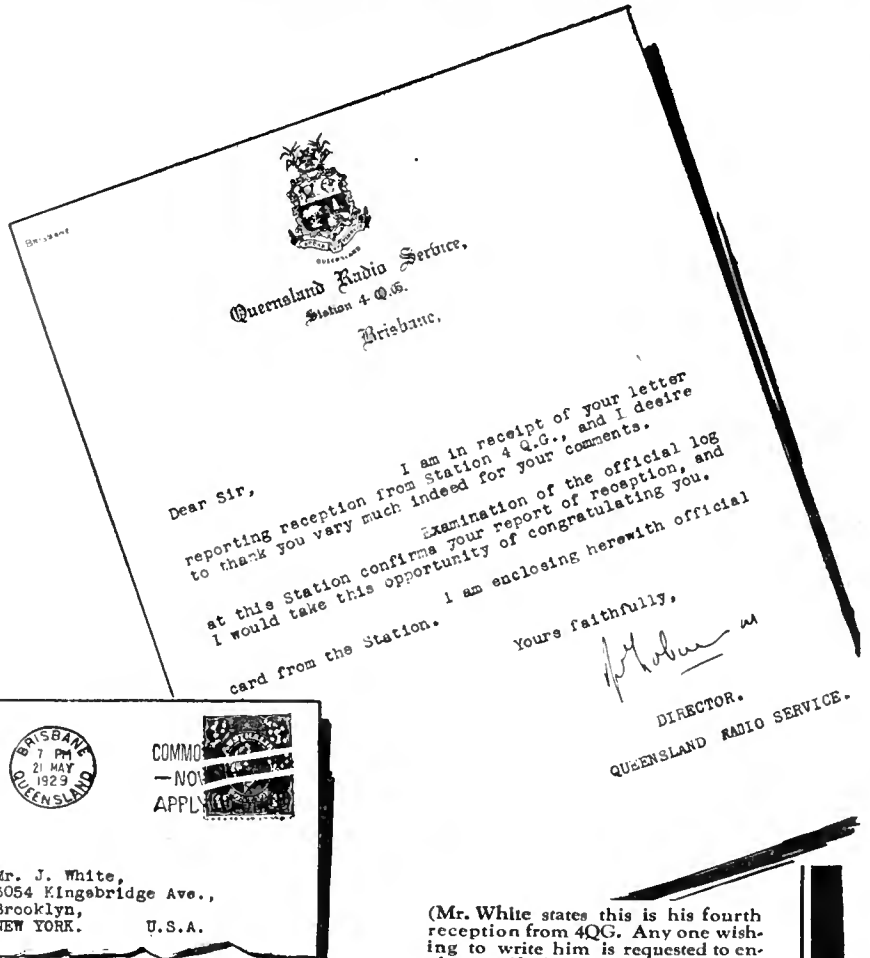

(Mr. White states this is his fourth reception from 4QC. Any one wishing to write him is requested to enclose a self-addressed envelope.)

### Never-Equalled Tone Fidelity With S-M Audio Transformers

Equally startling records for faithful musical reproduction have been made this season by S-M Clough System audio transformers. These remarkable instruments, practically eliminating hysteretic distortion in all types of radio receivers, are now available in a full line of models. The tremendously popular 255 and 256 straight audio types cost only \$3.60 NET, and correspondingly low net prices have been set on all other types, including push-pull and output transformers and chokes.

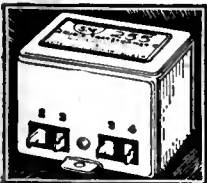

Setbuilders who have taken advantage of the unique franchises granted by Silver-Marshall, Inc., to Authorized S-M Service Stations have found that the building of radio sets and amplifiers from S-M standard parts is a highly profitable as well as an interesting business. If you build professionally, and have not investigated the Service Station proposition, ask about it now. And in any case, do not miss the monthly S-M "RADIO-BUILDER"; every issue contains big news for setbuilders. Use the coupon.

**SILVER-MARSHALL, Inc.**  
6403 West 65th St., Chicago, U. S. A.

### New List Prices (NET) on S-M Sets That Have Made History

S-M No.	Name	Scr.-Gr. Tubes	Wired Receiver	Component Parts Total
710	Sargent-Rayment Seven..	4	\$113.40*	\$78.84*
720	Screen-Grid Six.....	3	66.30*	44.79
720AC	Screen-Grid Six (A. C)..	3	70.20*	47.07
730	"Round-the-World" Four.	1	42.90*	31.71*
731	"Round-the-World" Adapter.....	1	30.00*	22.86*
740	"Coast-to-Coast" Four.....	1	48.60*	30.96
740AC	"Coast-to-Coast" 4 (A. C.)	1	50.70*	32.97

\*Price includes metal shielding cabinet.

Silver-Marshall, Inc.  
6403 W. 65th St., Chicago, U. S. A.

... Please send me, free, the new "NET-PRICE" S-M Catalog; also copy of the RADIOBUILDER.

For enclosed..... in stamps, send me the following:

... 50c Next 12 issues of The Radiobuilder

... \$1.00 Next 25 issues of The Radiobuilder

S-M DATA SHEETS as follows, at 2c each:

... No. 1. 670B, 670ABC Reservoir Power Units

... No. 2. 685 Public Address Unipac

... No. 3. 730, 731, 732 "Round-the-World" Short Wave Sets

... No. 4. 223, 225, 226, 256, 251 Audio Transformers

... No. 5. 720 Screen Grid Six Receiver

... No. 6. 740 "Coast-to-Coast" Screen Grid Four

... No. 7. 675ABC High-Voltage Power Supply and 676 Dynamic Speaker Amplifier

... No. 8. Sargent-Rayment Seven

... No. 9. 678PD Phonograph Amplifier

... No. 10. 720AC All-Electric Screen-Grid Six.

... No. 12. 669 Power Unit (for 720AC)

Name.....

Address.....

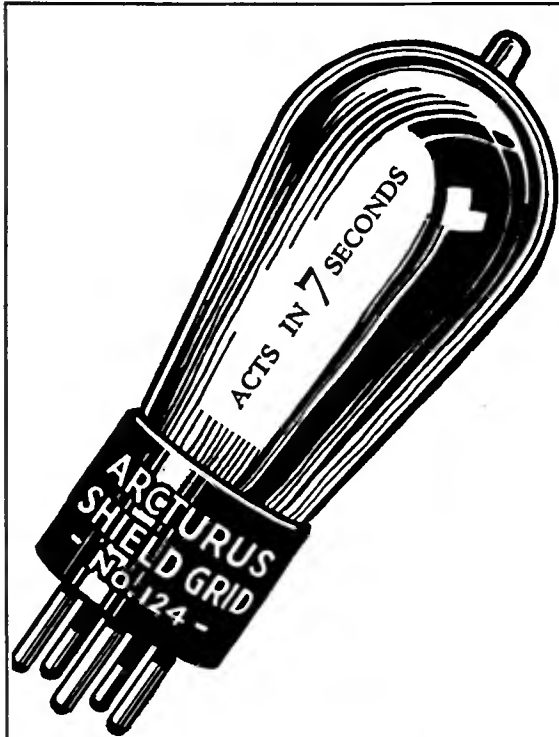

The **PIONEER**  
of the new  
A-C Screen-Grid Tube

**A YEAR AGO**—the Arcturus A-C Screen-Grid Tube was placed with set manufacturers. **TODAY**—leading set manufacturers use this new Arcturus A-C Screen-Grid Tube as standard equipment.

Arcturus *pioneered* this latest A-C Radio Tube development and is now building into the No. 124 A-C Screen-Grid Tube a full year's experience. Arcturus Tubes act in 7 seconds, give clearer reception as hum is banished, and they hold the world's record for long life.

Insist on Arcturus *Blue* A-C Tubes in your A-C set. Your dealer has an Arcturus A-C Tube for every socket. Try them today—you'll be amazed at the vast improvement.

ARCTURUS RADIO TUBE CO.  
220 ELIZABETH AVE. ~ NEWARK, N. J.

**ARCTURUS**  
BLUE LONG-LIFE TUBES

Jenkins & Adair

**Level Indicator Panel**  
Type B (Calibrated)



For Broadcasting, Electrical Recording, and Power Speaker Systems

The Type B Level Indicator Panel is designed for direct reading of the voice level on any 500-ohm telephone circuit, the range being from minus 10 TU to plus 20 TU, in steps of 2 TU each. The parts consist of an accurately built input transformer, a specially designed potentiometer, a filter retard and condenser, and direct current galvanometer calibrated for this work.

The use of this panel is essential wherever a specific level must be maintained. The calibration is highly accurate, and cannot alter while the tube constants remain normal. The potentiometer is built up of nichrome wire units, held to an accuracy of 1/10 of 1%. The panel is extremely simple in operation, is direct reading in TU's, and minimizes the change of load on the measured circuit when the level settings are changed. This last feature is a great improvement over present types.

The dimensions of this panel are 19 x 7 1/2 in. It is of 5/16 in. black sanded bakelite and weighs, complete, 18 lbs. It operates on 12 volt A battery and 135 volts B battery, and requires a 102E tube (not furnished by us). The parts of this panel are NOT sold separately. Bulletin 8 gives a more complete description and will be mailed on request. The net price in the United States and Canada is \$250.00 f. e. b. Chicago.

J. E. JENKINS & S. E. ADAIR  
Engineers  
1500 N. Dearborn Parkway  
Chicago U. S. A.  
Manufacturers of Recording Amplifiers

**TRUE VOLTAGE VALUES**

**TRUVOLT All-Wire Resistances**  
For eliminators and power packs, sell and recommend TRUVOLTS. Air-cooled, compact, sturdy and accurate. The fixed Truvolt has an exclusive feature—a sliding clip which permits adjustment to exact value desired. Stock sizes.

**TRUVOLT Variables**  
Distinctive Truvolt construction with a convenient knob for fine adjustment. Contact wires, giving unusual smoothness and longer life. One hole mounting. Simplifies eliminator construction. Avoids complicated calculations. 22 stock sizes.

Electrad, Inc., Dept. R B 7,  
175 Varick Street, New York, N. Y.  
Please send TRUVOLT literature.  
Name \_\_\_\_\_ Address \_\_\_\_\_

**ELECTRAD**  
INC.

**FROST-RADIO Brass Tack Talks on Rheostats**



Let's talk brass tacks on rheostats. You'll agree that the primary requisites in a rheostat are a character of design and a sturdiness of construction that will mean long life and

thoroughly satisfactory service. Rheostats must be designed *right* and built *right*. Frost-Radio Rheostats are mechanically and electrically *right*. They are built with the highest grade resistance wire wound on die-cut threaded flexible strips of genuine Bakelite. The German silver contact arm and spring are specially designed to give maximum pressure with minimum wear and absolute smoothness of action. All exposed metal parts are nickel plated and buffed. Arrow pointer knob is genuine Bakelite.

Every detail of Frost Rheostat design is the result of long study and of thousands of tests under all classes of service. As a result, our rheostats are eminently practical, good-looking, and serviceable to the Nth degree. We could not build them better if we sold them for several times our prices. In use they give a splendid account of themselves over long periods of time, with an entire absence of any sort of trouble. When you know how good they are you'll never order any other make except Frost-Radio Rheostats.

**HERBERT H. FROST, Inc.**  
Elkhart, Indiana  
160 North La Salle Street, Chicago, Ill.  
The World's Largest Manufacturers of High Grade Rheostats

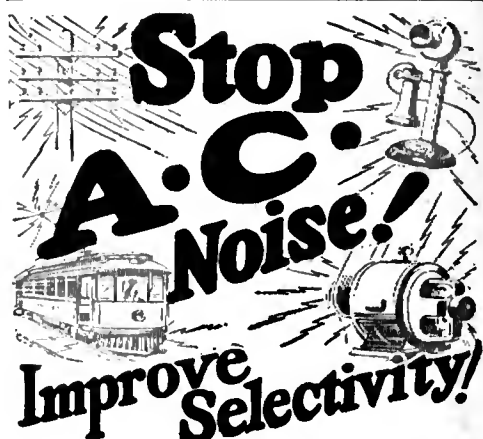

**PLUG** in a Falck Claroceptor between wall socket and radio set and eliminate "static" from motors, street cars, telephones and electrical appliances. This new improvement by a pioneer radio parts manufacturer grounds and thus blocks out line interference noise and radio frequency disturbances. *Also improves selectivity and distance.* Requires no changes in set. Measures just 3 1/2 x 5 1/2 x 2 1/2 inches. Thousands now all over America use the Claroceptor for clearer A. C. reception. Get one right away—at radio parts dealers. Write for descriptive folder.

**Falck**  
**CLAROCEPTOR**  
Built by ADVANCE ELECTRIC CO.  
1260 W. Second St. Los Angeles, Calif.  
JOBBER and DEALERS, GET OUR PROPOSITION



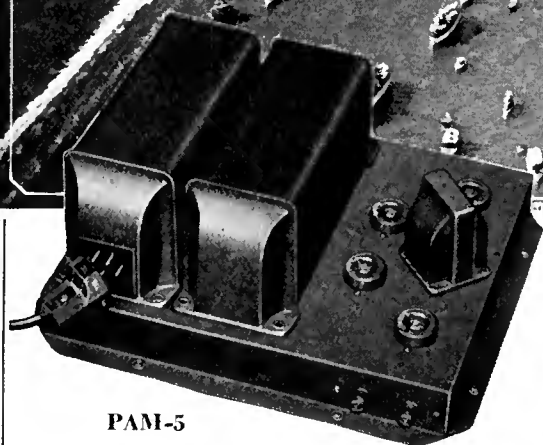
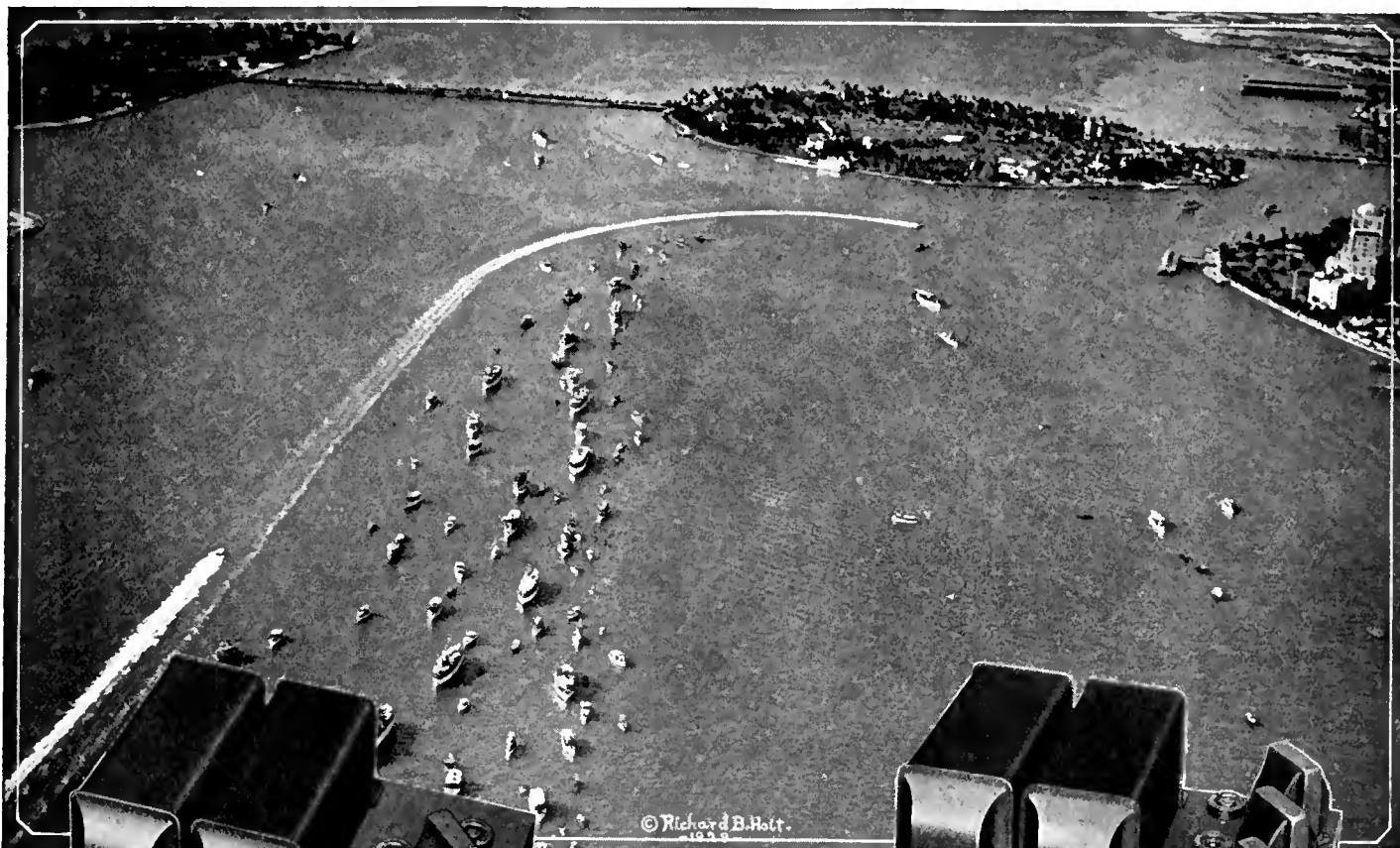

PAM-5

# PAM

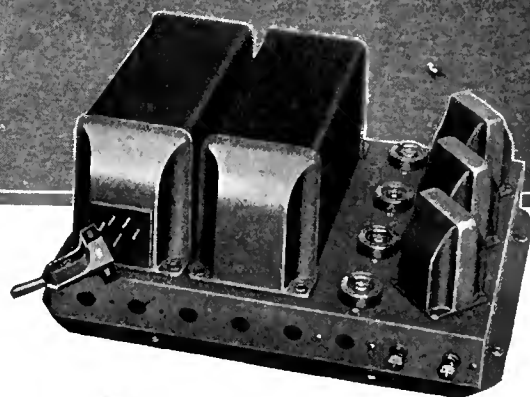

PAM-25

## Keeps Pace with the Best

PAMs kept thousands along the shore of Biscayne Bay in constant touch with every phase of the International Boat Race pictured above. The voice of the announcer was easily heard above the roar of the giant motors used by Gar Wood and Seagrave.

Wherever speed kings reign—on track, or ice, or sea—in this and other lands, there you will find PAMs which tell the crowds every detail of the contest.

Pictured above are two new PAMs, the PAM-5 which uses one 227, one 280 and two 112s, and is designed to work out of the detector tube of a radio set, a magnetic phonograph pickup, or microphone amplifier. Its output is such that it will feed any number of PAM-25s according to power output required for a particular installation. The PAM-25 uses two 281s and two 250s. When used in conjunction with a PAM-5,

it has a power output of 14 watts. Multiples of this undistorted output can be had by the addition of each PAM-25.

A new 16-page bulletin giving mechanical and electrical characteristics, representative installations, and many new amplifiers will be sent upon receipt of 10c in stamps to cover postage. Ask for bulletin No. RB8 when writing.

Main Office:  
Canton, Mass.

*Samson Electric Co.*

Manufacturers Since 1882



Factories at Canton  
and Watertown, Mass.

# RADIO BROADCAST

WILLIS KINGSLEY WING . . . . . Editor  
KEITH HENNEY . . . . . Director of the Laboratory  
HOWARD E. RHODES . . . . . Technical Editor  
EDGAR H. FELIX . . . . . Contributing Editor



VOL. XV, NO. 3

PUBLISHED FOR THE RADIO INDUSTRY

## Contents for July, 1929

Questions the Trade Show Answered - - - - -	132
Selling the Romance of Radio - - <i>Howard W. Dickinson</i>	133
The March of Radio - - - <i>An Editorial Interpretation</i>	136
Commission's Personnel Completed	Local Dealer Associations
Trends in Radio Merchandising	International Program Exchange
Educational Possibilities of Radio	European Radio Population Grows
Radio's Toughest Sales Problem - <i>Harry P. Bridge, Jr.</i>	138
What They Say - - - - <i>The Month's Best Letters</i>	141
The Trade-In Problem	Interference Haters
Analyzing the 1928 Radio Survey - - - <i>T. A. Phillips</i>	142
Professionally Speaking - - - - - <i>Keith Henney</i>	144
Needed—A Simple Battery Set	The New General-Purpose Tube
Value of Fundamental Knowledge - - <i>John S. Dunham</i>	145
In the Radio Marketplace - - - - <i>News of the Trade</i>	148
Loud Speaker Response Measurements - <i>P. H. Tartak</i>	152
Book Reviews - - - - -	153-168
Strays from the Laboratory - - - - <i>Technical Shorts</i>	154
Data on Foreign-Made Pentodes	Fluorescence in Radio Vacuum Tubes
Symbols Used in Technical Writing	
Engineering Behind a Crosley Set - <i>Kenneth W. Jarvis</i>	155
A Simple Line-Up Oscillator - - <i>Glenn H. Browning</i>	158
"Radio Broadcast's" Set Data Sheets - - - - -	159
The Majestic Model 180	The Sonora Model A-36
The Colonial Model 31 A.C.	The Freed-Eiseemann Model NR-78 A.C.
New Features in the Silver Radio - - <i>McMurdo Silver</i>	161
Why A.F. Transformers Burn Out <i>Herbert M. Isaacson</i>	164
The Experimenter's Armchair - - - <i>Robert S. Kruse</i>	165
Skip-Distance and Range Table - - - <i>L. C. Young</i>	166
Engineering Features of the UX-245 - - - <i>F. H. Engel</i>	167
"Radio Broadcast's" Home-Study Sheets - - - - -	169
No. 25. Buzzers in Radio Experiments	No. 26. Coupled Circuits
Design Details of the Fada Set - - - - <i>E. A. Uehling</i>	171
The Serviceman's Corner - - - - -	174
Radio Broadcast Laboratory Information Sheets	<i>Howard E. Rhodes</i>
No. 288 Index	No. 293 Regenerative R. F. Amplifiers
No. 289 Index (continued)	
No. 290 Filter Circuit Data	No. 294 Regenerative R. F. Amplifiers
No. 291 Voltage Doubling Circuits	No. 295 Tube Testing Circuits
No. 292 Voltage Doubling Circuits	
The Tube Business - - - - -	177

The contents of this magazine is indexed in *The Readers' Guide to Periodical Literature*, which is on file at all public libraries

## ... among other things

THE TRADE SHOW is over. It is of no importance to discuss whether it was "biggest and best" but it was certainly the most business-like of any we have yet attended. The arrangements this year provided for exhibitions and demonstrations in three hotels and, although they are quite close together, we believe it was generally agreed that the arrangement was a mistake. It is hoped that next year a location and city can be chosen where it will be possible to have exhibitions and demonstrations under one roof. We noticed among the dealers present an air of seriousness, a business-like attitude that appeared to have been less apparent in previous years. It seemed to us that those of the selling profession who attended were more interested in the merits of the merchandise shown than in more superficial matters. Dealers appeared more interested in technical features of the various offerings than in discounts. The Show was excellently managed by Clayton Irwin, Jr. and responsibility for the smoothness of the whole affair can largely be laid at his door.

AS FOR TRENDS—that word, we fear is almost becoming a bromide—there were many. These we have summarized on another page. It is without doubt, a screen-grid year. The engineers have seized upon the a.c. screen-grid tube because of its great technical advantages; the merchandisers have seized on the tube as a fine wedge to developing a new public appeal. Consumers everywhere are asking, What is this screen-grid? What does it mean? Dealers must be prepared to answer these questions and in a compelling reply will lie many new set sales. Undoubted public interest has been aroused by the screen-grid tube and it is the dealer who bears the greatest burden of translation. If 1928 showed the rise of the console cabinet, the 1929 show brings the console to its zenith. Table models were literally snowed under. All in all, it looks like a big year for radio.

OUR AUGUST ISSUE will contain the new special section devoted to the tube industry, a second article by our research department on the figures on the radio business, continuing the one in this issue, and a number of especially interesting analyses of business methods of successful dealers. In our engineering section will appear a technical description of the new Stromberg-Carlson set, J. M. Stinchfield of Cunningham writes on detection, and we will present a technical description of the Hazeltine Laboratories' system of uniform amplification.

—WILLIS KINGSLEY WING.

TERMS: \$4.00 a year; single copies 35 cents; All rights reserved. Copyright, 1929, in the United States, Newfoundland, Great Britain, Canada, and other countries by

DOUBLEDAY, DORAN & COMPANY, INC., Garden City, New York

MAGAZINES . . . . .  
COUNTRY LIFE . . . . . WORLD'S WORK . . . . . THE AMERICAN HOME . . . . . RADIO BROADCAST . . . . . SHORT STORIES . . . . . LE PETIT JOURNAL . . . . . EL ECO . . . . . WEST  
BOOK SHOPS (Book of all Publishers) . . . . .

NEW YORK: <LORD & TAYLOR, JAMES MCCREERY & COMPANY, PENNSYLVANIA TERMINAL, 166 WEST 32ND ST., 848 MADISON AVE., 51 EAST 44TH STREET, 420, 526, and 819 LEXINGTON AVENUE, GRAND CENTRAL TERMINAL, 10 WALL STREET> ATLANTIC CITY: <2807 BOARDWALK> CHICAGO: <75 EAST ADAMS STREET> ST. LOUIS: <223 N. 8TH ST. and 4914 MAYLAND AVE.> CLEVELAND: <HIGBEE COMPANY> SPRINGFIELD, MASS: <MEEKINS, PACKARD & WHEAT.

OFFICES . . . . .

GARDEN CITY, N. Y. NEW YORK: 244 MADISON AVENUE. BOSTON: PARK SQUARE BUILDING. CHICAGO: PEOPLES GAS BUILDING. SANTA BARBARA, CAL. LONDON: WM. HEINEMANN, LTD. TORONTO: DOUBLEDAY, DORAN & GUNDEY, LTD.

OFFICERS . . . . .

F. N. DOUBLEDAY, Chairman of the Board; NELSON DOUBLEDAY, President; S. A. EVERITT, Vice-President; GEORGE H. DORAN, Vice-President; RUSSELL DOUBLEDAY, Secretary; JOHN J. HESSIAN, Treasurer; LILLIAN A. COMSTOCK, Ass't Secretary; L. J. MCNAUGHTON, Ass't Treasurer . . . . .

# Announcing the **NEW**

## WRIGHT-DE COSTER REPRODUCER *Even More Wonderful*

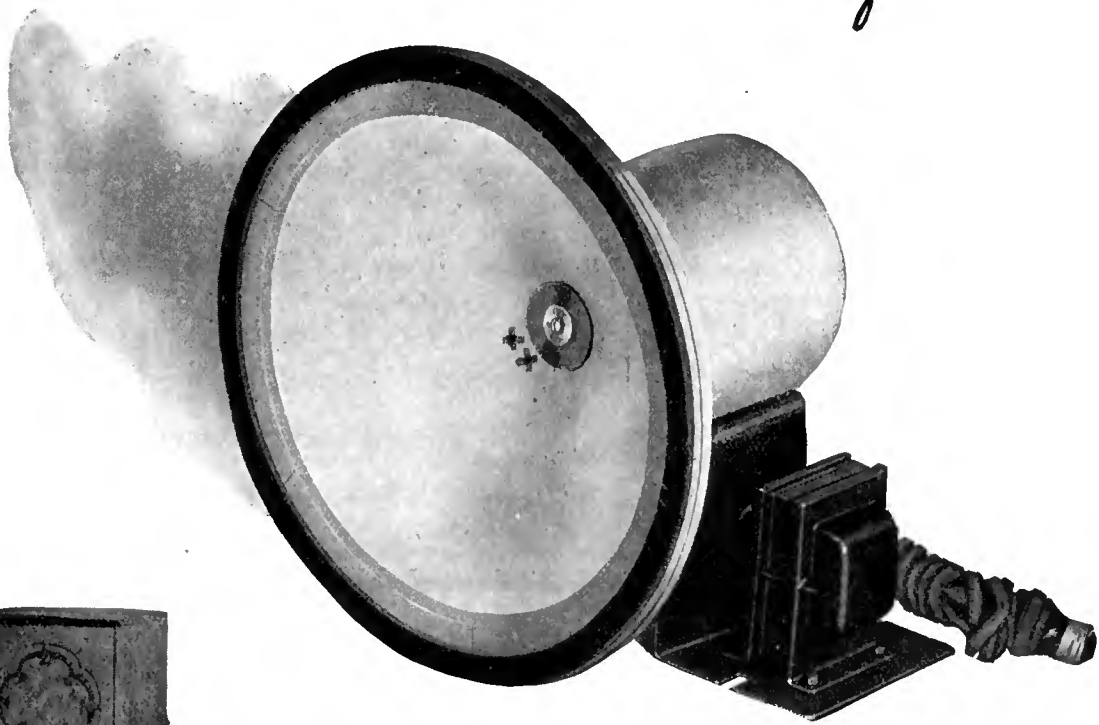

"E" Cabinet  
Small Console Model

*The Speaker of the year*

**NO HUM**

**D**ID you hear this speaker at the "R. M. A." show? Clear, distinct enunciation—no hum—Soft Mellow Music. Write Department R for descriptive matter and address of nearest district sales office. If you are in a hurry for a sample speaker order one at the same time.

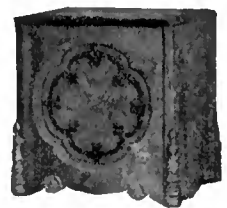

"D" Cabinet  
Table Model

**WRIGHT DE COSTER, INC.**

MAIN OFFICE AND FACTORIES

ST. PAUL, MINN.®



# Questions the Trade Show Answered

**A**LL eyes in the industry were turned toward the Trade Show in June and now the question is what did it mean, what are the lessons? A complete canvass of all the showings was made by RADIO BROADCAST in order to determine the trends and a summation of the set manufacturers' offerings. This summary, we present here. This summary is to be taken only for what it is—a tabloid rendering of the June exhibits. Many makers will have new models before September and by that time or before, some of the models involved in this tabulation will be altered in appearance, and design.

Reprinting of any part of this summary must not be made without our written permission.

**1. How many sets are using screen-grid tubes?**  
A large number, considering this is the first year that these tubes have been available. Out of the 215 models covered by our survey, 98 sets—45 per cent.—use screen-grid tubes and 117 do not. It looks like a landslide, doesn't it?

**2. What about the 245 power tube?**  
Consumers have complained about lack of power but now they will have lots of it. Out of 202 models, 156—77 per cent.—use 245-type tubes in push pull. Such amplifiers are 6.5 times as powerful as last year's sets which used a single 171 tube. The output of two 245's in push pull is 4.5 watts!

Only 8 per cent. of the sets use 250-type tubes, 13 per cent. use the 171-type, and 2 per cent. use the 112 type. The sets using 112-type tubes are battery operated.

**3. Consoles or table models?**  
Figures can't lie—only 16 per cent. of the sets at the Show were table models; the rest—84 per cent.—were consoles!

**4. How many tubes per set?**  
Of the new sets, 40 per cent. use 8 tubes, 27 per cent. employ 9 tubes, 23 per cent. have 7 tubes, and only 10 per cent. use 6 tubes.

**5. How many tubes will 1929 sets require?**  
A total of approximately twenty-four million tubes will be required for initial installations in new sets, figuring a sale of three million receivers averaging eight tubes each.

**6. How many screen-grid tubes will be needed?**  
At least half of the sets to be sold this year will use screen-grid tubes, it is estimated, and this will call for between 3 and 4 million of these tubes for initial installations.

**7. How much will sets cost in 1929?**  
Out of 212 models, 17 per cent. are priced at \$100 or less, 17 per cent. at \$100 to \$150, 31 per cent. between \$150 and \$200, 21 per cent. between \$200 and \$300, and 14 per cent. over \$300. Your customers can spend \$1000 or more for a receiver.

**8. What about the 226 tube?**  
Out of every 100 sets 74 will not use 226-type tubes—224- and 227-type tubes are being used almost exclusively.

**9. Push pull versus single amplifier tube?**  
Push-pull amplification is being used in 199 out of 202 models. The reasons are: quieter operation, better fidelity, and more power.

**10. Does the dynamic loud speaker hold its own?**  
Yes, in 97 per cent. of the models.

**11. How many phonograph radio combinations?**  
There are 22 such combination receivers out of the 202 models displayed. Generally speaking, they cost between \$300 and \$400. A few are lower in price.

TUBES			
Type of Tube	No. of models classified	No. of models using tube	No. of models not using tube
Screen-Grid Tube	215	98	117
245 Power Tube	202	156	46
226 A. C. Tube	202	53	149

PRICES OF RECEIVING SETS (Number of models below)					
No. of models classified	\$49.95-\$100	\$100-\$150	\$150-\$200	\$200-\$300	\$300 up
212	36	36	66	45	29

NUMBER OF TUBES USED IN SETS (Number of models using)				
No. of models classified	6 tubes	7 tubes	8 tubes	9 or more tubes
190	18	44	77	51

CABINETS		
No. of models classified	No. of consoles	No. of table models
198	166	32

LOUD SPEAKERS		
No. of models classified	No. using dynamic loud speakers	No. not using dynamics
215	209	6

POWER TUBES				
No. of models classified	No. using 245's	No. using 250's	No. using 171's	No. using 112A's
202	156	16	26	4

PUSH PULL		
No. of models classified	No. using push pull	No. not using push pull
202	199	3

AVERAGE PRICES OF VARIOUS TYPES	
Type of Receiver	Average Price
All models	\$204.00
All table models	80.60
All console models	240.00
All screen-grid table models	120.00
All screen-grid console models	235.00

**12. How about d.c. sets and receivers requiring batteries?**  
The industry has gone a.c.—at the show there were only 9 d.c. sets out of 190 models; these included both battery-operated and d.c. light-socket-operated receivers.

**13. Can chassis be purchased separately?**  
Twelve out of 46 set manufacturers will sell the chassis separately. The idea, of course, is for the dealer to install the chassis in a cabinet selected by the customer.

**14. What is the price range of new sets?**  
The cheapest set is a small table model for \$49.95; the highest priced set, a combination radio-phonograph, lists at \$2500. The average price of all sets is \$204.

**15. What are the new features?**  
Various forms of automatic and semi-automatic tuning control were evident. Three manufacturers showed a remote tuning control device which allows the user to control one receiver from almost any home location. Eight stations on the average can be tuned-to and the remote control also in each case allows for remote control of volume as well. One maker featured a remote control allowing not only pre-adjustment to eight stations but also provided for remote control of the entire movement of the condenser gang in both directions with provisions for stopping at any point. Automatic volume control is evident in the higher-price field, but the trend is not yet general. Some indication that the local-distance switching arrangement is returning to popularity was evident and this feature was noted chiefly in screen-grid sets. Cabinet design is best described as good, but uneventful. Ease of servicing has been considered by the majority of makers and without exception, receiver design is more simple, more sturdy. Unit construction, in which the tuning unit is separate from the power-audio units for ease of servicing is a very distinct trend. Prices have come down as our summary shows.



HOWARD W.  
DICKINSON

writes on—

## How the Dealer Can Improve His Point of View

The author of this article, Howard W. Dickinson, is a merchandiser of the widest experience. For many years he was executive vice-president of the George Batten Company, one of the best known of our advertising agencies. Here, he was in constant touch with business problems in a wide variety of fields, notable among which was radio. While connected with Batten, Mr. Dickinson among others was in charge of the advertising account of the DeForest Radio Company and the Cliquot Club Ginger Ale Company. The famous Cliquot Club "Eskimo" program was begun by him and his experience with radio matters goes back into the early history of the business. Mr. Dickinson is now spending his entire time in writing about his special field of knowledge—merchandising—and his articles appear regularly in *Printers' Ink*, *Advertising and Selling*, and many other general publications. He is the author of two books, *The Primer of Promotion* and *Crying Our Wares*. When Mr. Dickinson writes about radio merchandising, he knows whereof he speaks and we are sure his articles will be read with the widest interest.—THE EDITOR.

## SELLING THE ROMANCE OF RADIO

**I**F I WERE to be asked what one thing the radio retailer needs most of all to help him in his business, I should say a great increase in ability to gloat a bit, nicely of course, over the importance of his business and the charm of the things which he sells.

He is very practical and scientific. It may pay him immensely to learn the art of telling some of the true fairy tales which his industry is full of.

Maybe someone else can tell you the proper relation between inventory and annual sale. I can't, and I am not sure that anyone else can in exact terms.

Somebody else may tell you a whole lot more about window display than I can. I only know when I like to look at a show window. I have found two types of windows that I like to look at. One is the kind that is filled up with tools or other things which interest me. The other kind is where genuinely artistic effects of color and form demand attention and admiration. Beautiful as the second kind may be, I am apt to be just entertained by it, while the display of real things often compels me to go in and buy. A combination of the two is irresistible.

### *The Average Dealer's Viewpoint*

**I**HAVE BEEN in many a radio shop. I always feel as if the proprietor or even the man behind the counter is my superior in one very important respect. He knows a great deal about a very interesting subject of which I know but little. He is a magician to me. He deals with one of the most fascinating and delightful fruits of scientific magic. What is a mystery to most of us is an open book to him.

He knows the fascinating labyrinth of wires and coils. He knows how the tiniest force imaginable is caught, focussed, and

amplified. He knows the multiple function of the vacuum tube. And he calls it all a "Hook-Up."

Respect and admire him as I do, I am a little bit ashamed of him too. I do not dare to voice my enthusiasm to him. He looks so sophisticated and practical. He seems to be selling diamonds by the pound and not by their lustre and quality.

He seems to have left me to pick up the romance of radio wherever I will—if I do pick it up at all; he is willing to sell me a machine.

### *The Radio Dealer's Position*

**N**OW I AM supposed to be an advertising man, a practical chap, and one might wonder why I talk like this. In this article, and the few which may follow it, I want to help make a better salesman out of the radio retailer. So far, it seems to me, he has been pretty much in the position of the coffee and sandwich man just outside the gate through which a hungry crowd is pouring. He hasn't been obliged to sell for he happens to have things which people wish to buy. There is a difference. The radio dealer has been a purveyor to actual demand. He hasn't been compelled to stimulate general demand as have merchants in many lines. For example, how many radio dealers make the slightest effort to help sell broadcasting itself or give the slightest thought to the matter of helping people to enjoy radio.

Look in the window of an office for selling transportation over the Great Northern or the Canadian Pacific. Get their folders and you are treated to wonderful views of Glacier Park or the Canadian Rockies—things to see and the fun of seeing them.

Radio broadcasting is full of interesting things and interesting personalities. You are in a fascinating and romantic business. Why not make that fact pay you bigger profits by



learning how to stress it? Radio has developed fast but it is by no means an "old story." The romance of it is still there. Are you so completely scientific that you can talk only in terms of "selectivity," "distance," "elimination of static," "one-dial control," and so on? Are you so completely practical with respect to price, durability, current consumption, and such things that you can't encourage the very practical sales art of sympathizing with the romance that is in the soul of the set buyer just as the romance of lakes and mountains is in the soul of the trans-continental traveller?

### *Promoting Your Business*

**A**H, I AM really afraid that you have a superiority complex. I come to you about something you know much more about than I do. I show my respect for your knowledge, then you feel that you must be an oracle and in your kindly but positive way talk down to me. You can still show your knowledge, but, if in addition to your superiority in knowledge you have the art of sympathizing with me as a real or possible radio nut, you can make more money out of me. Really, aren't you the least bit inclined to "high-hat" me because I am an ignorant dub about hook-ups and such things in which you are wise?

Can't you realize that if I just have a radio set in the house because every one does, and that I have brought it to you for repair because my daughter said I must, it might pay you to get a bit of enthusiasm pumped into me about radio and the fun I can have with it myself? If you succeed in that I am not going to be satisfied with this old set that needs repair every few months. You must be a salesman to get the most

out of your business, and salesmanship is largely a matter of understanding the customer.

Promotion of your business is what I am talking about. If you can in the course of time get fifty of your customers to realize that you are interested in the quality of broadcasting, the fun of listening in, and selectivity with reference to *programs*, then you may make more sales than you now expect to. To you the important thing is the quality and price of instruments, to me the really important thing is radio programs. If you jump that gap yourself and get on my side of the ditch your influence with me will double. I'll still know and admire your scientific qualities and your technical skill. Yes, even more than ever because you sense my need and I recognize that you are a broad man.

A dealer is rather bound by the established routine of buying and selling. Sometimes that is rather drab and uninteresting. Selling easily gets into a stupid rut. Sometimes a single dealer and sometimes a group of dealers make a plunge into a profitable cultivation of the spirit of romance—that imperishable spark which lives in us all, even in this sophisticated age.

### *Romance in Other Industries*

**S**AY IT WITH FLOWERS." A great industry has united to spread this romantic touch, and it has done so with enormous profit. Even the old substantial Western Union has branched out into romance, and, strange as it may seem, has made a Cupid out of the messenger boy who delivers thousands of love notes sent by wire. Greeting cards, particularly at Christmas, have offered incense on the altar of romance, good



*Following Mr. Dickinson's ideas, the actual show window pictured above has been designed to suggest a radio installed in the home. It causes the observer to consider radio as a practical utility rather than a complicated mechanical device.*

wishes for years now—and more than ever will go out next Christmas.

That same chummy, friendly, human element is in radio. Radio is full of it. People like to talk about it. Do you use it for all it is worth? Do you perhaps pride yourself in being *only* on the mechanical side of this industry? Do you fail to interest yourself in the art side? Do you fail to realize that the art of selling canned salmon is a very different art from that of selling flowers, or pearls, or pictures, or radio?

### *If I Operated a Radio Store*

**W**HAT WOULD I do about it if I operated a radio shop? A fair enough question. Specifically, I don't know. Generally speaking, I'd try to get some of the atmosphere of broadcasting into my shop. I doubt if I'd do it by having a loud speaker over my door with its noises mixing with the street noises into a blend of discord. If I fancied the microphone work of Graham MacNamee or some other famous announcer, I think I'd try to have his picture in my shop. I'd expect it to start some conversation which might make a sale. If I had pictures about I'd have some good ones of announcers and artists. I'd make all the "hook-up" I could with the broadcasting side of radio. Separate parts of an industry are very prone to isolate themselves from each other to their mutual detriment.

I believe I would employ a store decorator and tell him or her that I wanted a genuine atmosphere of broadcasting as well as of the mechanics of radio. I'd consult that decorator and try to work out something fine. If a manufacturer who sold me goods should also send me cheap-john lithographs I'd send them back and tell him what was wrong with them.

I'd study the problem from all angles, consult authorities if I could find them, and try to work out something which gave to my shop the physical aspects of romance, the existent romance which radio still means. I'd show graphically, in any way I could, the news values and the educational facilities which radio offers as well as the art values.

"Everybody knows all about radio." Guess again. Nobody knows all about radio, and the majority know but very little. It is easy to show most anyone how much more fun and profit he can have from radio.

### *Keeping Radio Alive*

**D**ON'T LET the romance of radio be absent from your shop! We will keep radio alive and growing by keeping its romance alive. We have to assume that our dealer knows the elements of retailing, knows how and what to buy, and how to mark up to make a profit. What we are concerned about particularly is the extra chance of business, maybe 20 per cent.,



*Your customer's interest is in programs. If you jump the gap and get on his side of the ditch your influence with him will double*

maybe more, in which profits lie. That extra chance lies in the personality of a business, its artistic and social good will, its ability to be friendly and instructive.

Put an understanding of the fine points in human relationships on top of the knowledge which a radio merchant must have and his selling chances begin to increase rapidly. If I could give the radio man a phrase to remember about his business it would go something like this: "Commonplace and familiar to me, very interesting to others." I think our dealer is apt to know so much about his trade that he forgets the fact that others do not know so much, and that they can be interested easily in anything pertaining to radio. He knows much about it. If he keeps that knowledge all in his head he misses a big chance to use it at a profit. If he makes his shop a fascinating place to visit, more people will visit it. If they are shown things there more people will buy.

Simple? Yes, but easily forgotten, and the radio dealer has this advantage to a greater degree than most others. He has a more interesting product to sell than most others.

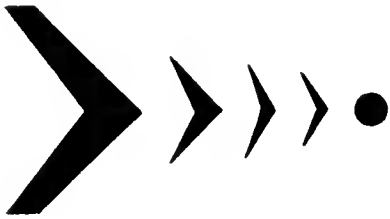

# The MARCH

New Hope for Clearing the Ether  
The Rural Radio Dealer's Problem

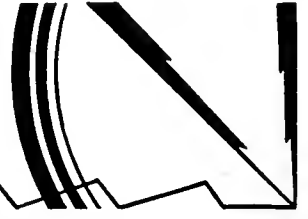

## Commission's Personnel Completed

**W**HETHER A MORE forceful policy will be adopted by the Commission, now that its personnel has been completed by the appointment of General Charles McK. Saltzman for the Fourth Zone and William D. L. Starbuck for the First, only experience will determine. We may take slight comfort from the fact that four minor stations have been denied renewal of their licenses and a few others placed on probation. Threats have been made regarding frequency deviations, but we must confess that warnings by the Federal Radio Commission have been issued too frequently in the past without being followed up to warrant taking them seriously.

It is obvious to any unbiased observer with a sensitive receiver that the clear and the better regional channels render such greatly superior service, as compared with that of the local and poorer regional channels, that any move to crowd these channels, further is absolutely contrary to the dictates of common sense. Nevertheless, new licenses continue to be issued and power increases are permitted on the regional channels. We earnestly hope that some of the serious experiments now being conducted in synchronization will help to reduce the number of heterodynes on the shared channels. Apparently it is a vain hope to rely upon the Federal Radio Commission to undertake the prime function for which it was originally organized, namely the drastic reduction of the number of stations operating, and hence synchronization is the only remaining hope for improved conditions.

In dictating strict adherence to frequency stability and staunchly defending the clear channel, the Commission may still serve an important and useful purpose because it is only a matter of time before engineering advances in synchronization will help materially in improving the quality of reception provided on the crowded channels. But even this hope will be destroyed if too many new stations are licensed and too many power increases are allowed on local and regional channels.

## Trends in Radio Merchandising

**I**T IS AS much the concern of the radio receiver manufacturer as of the radio dealer that retail merchandising shall be profitable. Receiver manufacture has proved a profitable and satisfying enterprise for most of those engaged in it with adequate capital and sales and engineering ability. However, if the dealer who retails the receiver does not enjoy this same prosperity, his failure will soon be reflected in the profits of the manufacturer.

With quantity production, drastically lower prices, and a great increase in the number of effective selling outlets, the lot of the smaller dealer in the radio field, particularly in the less-populous communities, has become more and more difficult. The unit of sale grows smaller and, although the turnover is increasing, it [is not sufficient to counteract completely the smaller profits per sale now



made. The average sale has fallen to about \$158. This still leaves an ample margin for efficiently conducted radio businesses. Efficiency implies low overhead per dollar of sale and that, in turn, depends upon a considerable turnover. Where large sales volume is not attainable, the dealer may operate without profit. There is much complaint to this effect at every dealer's meeting. Usually the answer lies in lack of sales ability, poor selection of lines, or excessive competition.

Nevertheless, there are locations where none of these factors account for the dealer's failure to show profit. In such cases, sales are made almost entirely in low-priced merchandise, but population and economic conditions preclude the building up of adequate sales volume.

In the smaller community, the answer to the dealer's problem lies in the development of a more comprehensive business by the sale of allied non-radio products. A manufacturer who would ingratiate himself with dealers serving rural areas could very profitably make a study of the economic position of the rural dealer with a view to point out solutions for his individual problems.



## Educational Possibilities of Radio

**A**BRIEF REVIEW of the British Broadcasting Corporation's latest edition of *Talks and Lectures*, a leaflet issued periodically to assist in taking advantage of its comprehensive educational lecture service, is sufficient to convince any American listener that we are overlooking many of the richest possibilities of radio broadcasting. While no educational lecture is greeted with enthusiasm by a majority of the audience, those whom it does serve are served significantly and the benefit accruing to them is of far greater permanent value than could possibly be derived from the type of program which is the stand-by of American listeners.

We have to blame the economic system upon which our broadcasting is based for its lack of genuine service value. There is no progressive or comprehensive plan to take advantage of the educational opportunities which the microphone offers. Morning talks, presented for women, are little more than blatant and direct advertising of the most forlorn and discouraging type. Since the support for broadcasting is obtained on the strength of the good will accruing to national advertisers, it is natural that features should be presented which attract as broad a cross section of the listening audience as possible. This precludes any serious educational effort and levels all programs to a standard level of appreciation.

Radio is principally a serviceable instrument for securing a background of music in the home with a minimum of effort. There is sufficient variety to appeal to any average musical desire. During political campaigns and outstanding sporting events, radio serves very acceptably as a news reporting device. But this is about as far as it goes and the serious constructive purposes served are highly exaggerated.

There is just as great a field in child and adult education in languages, dramatic, and literary criticism, travel, history,

# OF RADIO

## Advantages of Dealer Cooperation American-British Radio Programs

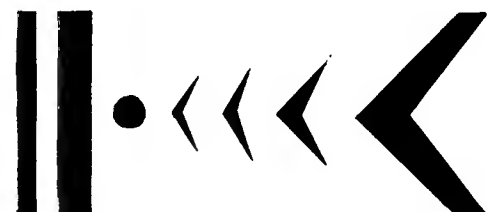

and home economics as there is in broadcasting classical music. This the British Broadcasting Corporation has adequately recognized; in fact, it has probably gone as far in stressing these subjects too much as we have in relegating them to obscure hours. Talks are not compressed into five or eight minutes; they are half-hour lectures, presented by outstanding speakers. They use not only our conventional

hour of 10:45 A. M., addressed to women, 3:30 P. M. to women and children, but also such evening hours as 6:00., 6:30, 7:00, 7:25, 8:15, and 9:15 for regularly planned lectures.

The presentation of such programs would not appeal to the national advertiser because there is no educational subject which interests a broad cross section of society, and serving only a part of the audience well does not have the good will value of serving a larger part in an insignificant way.

The broadcasting companies should make some effort in the direction of educational programs as sustaining and good-will features. "Sustaining" programs, however, have begun to designate fill-in periods which cannot be sold commercially rather than any effort to embellish the radio fare.

A close scrutiny of available educational features from all stations serving the more-populous radio areas does indicate that a fairly broad range of subjects is discussed before the microphone, but this is done in such a disorganized manner and at such hours that the listener who concentrates upon two or three stations for his program service hardly has occasion to know that there is anything of an educational nature on the air. The newspapers have taken to publishing programs in a rather sketchy and uninformative manner so that they serve as but little more than a reference guide to those already familiar with the nature of the features offered.

A dealer might serve a useful purpose by sending a regular bulletin to his customers and prospects giving in some detail the educational features which the listener in his territory has available through his radio receiver. This information, conscientiously collected, would have a surprising amount of sales appeal not only among highbrows but among all classes of listeners. The desire for self-education is strongly inherent throughout the American public as anyone familiar with the enormous enrollment of correspondence schools from all classes of society can testify.

### Local Dealer Associations

IN MOST cities of less than a hundred thousand population, the number of dealers is too small to warrant a local dealer's association and the mutual problems which such an association might discuss are hardly suited to cooperative action. But, in larger cities, there are many fields for useful cooperation. Local man-made interference can be tackled effectively by such a body; cooperation with



local broadcasting stations effectively maintained, trade abuses corrected, and delegates sent to national conventions of dealers so that the whole community may be benefited by their report. This department would welcome correspondence with successful local dealer associations in order that their experiences may be made of benefit to other communities which have not yet appreciated the potential value of a local dealer organization.

### International Program Exchange

THE RECENT trip through Europe, taken by Merlin H. Aylesworth, president of the National Broadcasting Company, can be counted on to produce some significant results in international broadcasting. While the technical problems must first be solved, the value of the impetus given

by personal contact of the leaders in broadcasting on both sides of the water is certain to spur on the efforts of the engineers. C. W. Horn, recently appointed general engineer of the N. B. C., is encouraging technical progress in the same

manner that Mr. Aylesworth is cementing the executive relations of the two principal broadcasting systems of the world, the N. B. C. and the B. B. C. There is a romantic tinge to international re-broadcasting which is certain to increase the market for radio receivers in both countries.

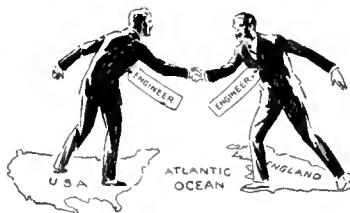

### European Radio Population Grows

CONTINUED INCREASE in the number of licensed listeners in European countries is indicated by statistics for the years of 1927 and 1928. The total number of license holders rose from 5,897,000 to 7,163,000 or 21.4 per cent. The British total, on January 1, 1929, was 2,684,941; the German, 2,635,537. The following is a tabulation of the number of licensed radio receivers per 1000 inhabitants:

	1927	1928
Denmark . . . . .	57.05	76.42
Sweden . . . . .	54.68	63.47
Great Britain . . . . .	56.91	59.48
Austria . . . . .	47.79	53.31
Germany . . . . .	33.49	43.92
Norway . . . . .	22.9	22.9
Hungary . . . . .	10.41	20.1
U. S. (estimated) . . . . .		68.1-90.9



New powerful broadcasting stations are likely to make significant changes in several European countries during the next year.

The estimated number of radio receivers per thousand population in the United States lies between 68.1 and 90.9, per thousand, according to the enthusiasm of the statistician. If he is trying to estimate the market for receiving sets, it is the former figure; if he is trying to sell radio advertising, it is the latter. The smaller figure, however, is probably very much closer than the latter.

—E. H. F.





*Used set display of the Germantown Radio Co. Note that every set is plainly tagged, the low price at which they are offered being a decided asset in promoting their ready sale.*

## *What to do With Used Sets*

---

# RADIO'S TOUGHEST SALES PROBLEM

---

By HARRY P. BRIDGE, JR.



TO TRADE or not to trade?

This, says H. G. Emsley, of the Germantown Radio Company, 5431 Germantown Avenue, Philadelphia, Penn., is the question. More than that, this matter of accepting old sets as partial payment for new ones is his toughest sales problem.

"The trade-in market is a big one," says Mr. Emsley. "That is one reason why it is so hard to find just how to tackle it. The dealer who rushes headlong at it is apt to see only the opportunities and overlook the pitfalls. I've stepped into a few of them and almost stepped into a lot more."

He adds: "Almost every radio set owner, other than those who have sets of the most modern light-socket-operated type, is a good replacement prospect. That's one of the good features about the radio business. New developments are coming along all the time to make repeat buyers out of old customers and thus stave off the saturation point in sales that is so much of a worry to a lot of long-established industries. The really big problem in this connection is not how to interest present set owners in the latest and best but rather how to make the old sets pay their way. As long as a set works, an owner won't

scrap it. Chances are, he has an exalted idea of its trade-in value. What is more, the dealer who does take it in at a fair price still has a goodly share of his profit on the new set tied up in the old one until it is satisfactorily moved."

Mr. Emsley is not given to personal publicity and self praise. It was hard to get him to talk about his solution of this problem—not because he was loath to pass along any ideas he might have but for the simple reason that he can see little of an outstanding nature in what he has done in this respect. Perhaps that is so. The fact remains that he has built up a surprisingly stable year 'round business selling radio alone—also that his ability to handle trade-ins has been responsible for his success in no small part.

This dealer has been in business in this prosperous Quaker City suburb for more than six years. Each year has shown a substantial increase in his business, and the business has been good from the start. Last year showed a 20 per cent. increase over that of the year before and he is planning on a similar growth in 1929. It is not unusual for him to sell as many as 30 or 40 used receivers in a week. Moreover, he does it without any advertising other than that given by frequent window displays. No high-pressure selling is used



to persuade set owners to trade in old sets on new ones, and therein lies the story of Mr. Emsley's solution to the problem. He has found that this is not necessary to get all of this business he can safely handle.

As he has already hinted, one of the greatest difficulties came in knowing where to stop in dealing with the replacement market. Piles of old and hopelessly unsaleable sets on dealers' shelves plus a generally soured outlook on the part of the proprietors concerning trade-ins are mute evidence that many have failed. In going over the new sales they have over-estimated their ability to re-sell the old sets and sell them at a profit.

Early in the game, this dealer decided three things: first, that haste must be made "slowly" in the handling of trade-ins—that to tap the market any faster than the old sets could be resold would be both foolish and unprofitable; second, that definite policies with regard to used sets must be formulated in order to take this end of the business out of the hit-or-miss class, and, third, that it is just as important to build consumer confidence in the second-hand outfits as it is in the new ones.

It may seem somewhat paradoxical to say that Mr. Emsley does not aggressively seek trade-in business, yet this is merely a natural development of his policy. He does, however, have a definite and straight-forward proposition to put to every trade-in prospect and he knows exactly what to do with a used set after he gets it. As a consequence, he has become widely known as headquarters for the radio owner who wants to trade in his old set on a new one. More than that, his store is something of a mecca for the man who wants to buy a good reconditioned outfit at a reasonable price and with a reasonable guarantee of satisfactory operation.

At least one prominent radio manufacturer bases his yearly production largely on the number of sets he has made the year before. He knows that a good set is its own best advertisement and feels that one satisfied customer will beget many more.

### *Fair Deal Brings Trade*

SO IT is with the trade-in business, Mr. Emsley has found. One customer who gets fair value for his old radio is quick to tell a friend who likewise becomes a good prospect. And so it goes. Consequently, by conscientious handling of the

business, Mr. Emsley has built a substantial volume—and, by putting something of a curb on his original ambition to cut a wide swath through the used set market, he has avoided the danger point which lies in having more used sets on the shelves than there are buyers to be found. By "making haste slowly" he is progressing steadily year by year, and he learns rapidly as he goes without paying a high price for the experience or jeopardizing his future.

The fact that he has sold as many as five sets to a single customer in a comparatively short space of time is indicative not only of his success but also of the manner in which the market may be made come to the dealer under these methods.

Allowances for used sets represented a ticklish problem.

"There are exceptions to all rules," says Mr. Emsley, "but one of the most rigid rules a dealer should have is that of refusing to accept an old set unless it can be resold. More than that, I have found that it is not safe to base trade-in allowances on the original cost of the set. The one and only thing to be considered is its resale value. If that doesn't amount to a little more than you'll be called on to give for it, then it had best be let alone.

"To take a used set with the idea of discarding it and figuring the allowance as part of the cost of making the new sale is just another way of cutting prices. I never felt it was sound business to cut prices literally and I don't believe it is sound business to do it this way, either. Besides, in the long run, I have found it isn't necessary."

As a consequence, some of the most profitable business, so this dealer says, is the business he doesn't get at all.

If he can't make a sale produce a profit, then he is content to pass up the sale in favor of any other dealer who sees fit to make it. Prospects who insist that they can get a better allowance elsewhere are told politely but convincingly that the company's offer was carefully estimated and is the best that can be made.

"Naturally," says the proprietor, "the best allowance you can possibly make on a set often seems mighty low to a customer who doesn't realize that radio is pretty much in the same class as automobiles in this respect—perhaps more so. Frequently, people of this kind can be made see the 'light'—sometimes not. In a number of cases, I have been successful

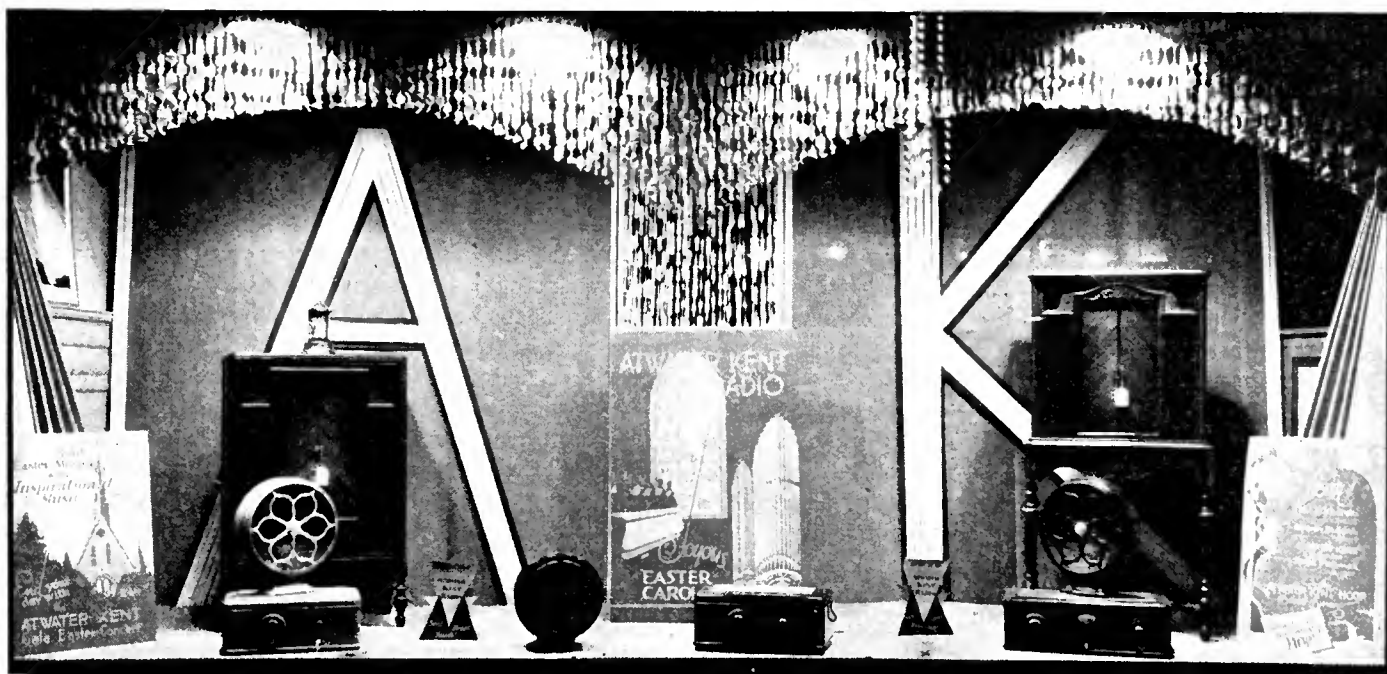

*An attractive window showing how new sets are displayed by the Germantown Radio Co.*

in getting these folks to dispose of the sets themselves. They can do this by advertising them in the classified columns of the local newspapers or giving them to friends or relatives. Many people are susceptible to the latter suggestion, especially when it is put to them that the satisfaction of giving a radio to a deserving party would likely be worth far more than even the best trade-in allowance."

Emphasis is placed on the service on new outfits offered by the Germantown Radio Company and no attempt is made to beat around the bush in showing that this is made possible only by fair profits on every sale. Through the years, Emsley service has become so well known that this argument usually swings the doubtful sale.

### Importance of Service

**T**OO MUCH stress cannot be laid on this particular point for Mr. Emsley feels that prompt, efficient service has been the most important factor, not only in building up his business generally but particularly in making it possible for him to gain such a large used set volume. While other dealers were still debating as to the handling of service, and while some were rendering more or less indifferent service only on the sets they had sold, Mr. Emsley had this end of his business unusually well organized.

Whether radio owners who called for assistance were customers of his mattered not at all. All received visits from skilled men in 24 hours or less. A fleet of trucks not only made it possible to extend this work over a large territory but effected worthwhile economics as well. These same trucks are equally useful in facilitating new installations.

Sets sold by this company are serviced for three months without charge while the service cost to others is decidedly moderate. Almost from the start, this department has paid its way directly. Even more important have been the indirect results. People who did not buy their receivers from the Germantown Radio Company originally did come when they were ready to get new ones.

"If there's any one factor that is important in building for success," says Mr. Emsley, "it certainly is the right kind of a service department. It is particularly indispensable if you handle used sets for that is when you reap the full benefits."

No old sets are accepted "sight unseen" nor are allowances based on the prospect's description of them. Estimates are sometimes given in this manner but a definite offer is never made until a serviceman has visited the home and passed expert judgment on the outfit in question.

Particular pains are taken to create a feeling of confidence in the concern's used sets and, consequently, to create a broader market for them. Every old radio that comes in is gone over carefully by the service department and put in the best possible condition. Tubes, batteries, power-supply units, and other accessories are carefully checked and replaced where necessary. Frequently, cabinets are refinished. Dubious trade-ins are never sold for the company will not accept a radio it cannot pass on with a genuine assurance of value received to the customer.

In the isolated instances when complaints do come in, no

time is lost in making good providing they are made within a reasonable time and also providing that the fault lies in the set and not in a customer who expects too much of it.

Used sets are sold for just what they are—no more, no less. As with new radios, customers are not led to anticipate the exceptional in distant reception, performance, and the like. They are led to realize that, while no radio is perfect, the right kind of an outfit properly operated and properly serviced offers a truly delightful orchestra seat at the "Theatre of the Air." That, says Mr. Emsley, is the only way to insure lasting and widespread consumer satisfaction.

All used sets are sold for cash only—and they are sold quickly. There is no carrying over of large stocks from month to month, much less from year to year. This dealer has long recognized the importance of prompt turnover and is just as alert in applying this experience to trade-ins as to his general stock. As soon as a supply begins to accumulate, into the window they go. Thanks to the combination of his splendid location on a busy main thoroughfare plus the enviable reputation he has built through the years, no other sales impetus has been necessary.

Old sets are never displayed in the window for more than a week at a time. The fact is, sets are sold directly from the window and as fast as one is sold another old one is displayed in its place. However, even in this manner used set displays are not kept in the window for more than a week. From ten to fifteen sets (depending upon their size) are kept in the window at a time, all being plainly marked with price tags. During the October season last year Mr. Emsley

sold his complete stock of used receivers (about forty sets) in three complete displays within a week.

Resale prices on used sets at the Germantown Radio Company run from \$8 to \$25 with the average being in the neighborhood of \$15. Radios priced at the latter figure are generally the most saleable. Occasionally a used set is sold for as much as \$50 but such a case is the exception rather than the rule.

The best seasons for disposing of used sets are during the Fall and immediately after Christmas. Mr. Emsley explains that they sell particularly well at the latter time, either to people who did not receive the radio set they wanted for Christmas or to those who received a little money which was insufficient for the purchase of a new set.

Although he frequently does not make as much on the sale of second-hand equipment as he does on the sale of new, Mr. Emsley sees to it that the resale price allows for a fair margin. Otherwise he figures he would be making two sales to produce a single profit. Once in a while, it is found necessary to reduce the price on a used set to bring about its ready removal in line with the proprietor's ideas on turnover. He realizes that the longer a set remains unsold the greater is its cost to him.

Do not misunderstand the nature of the business of the Germantown Radio Company through a reading of this article. Despite the fact that he regards trade-ins as his toughest problem, Mr. Emsley's aim is first, last, and always the sale of new sets. His is not a business in second-hand material. He has found, however, that the ability to handle trade-ins in a high-grade, strictly ethical manner has greatly increased his market for new sets and consequently enlarged the profits of his store.

### Please Note—

*What a successful dealer does with trade-in sets. See page 138.*

*Applying a new idea to retailing radio. See page 133. Percentages by states of a.c. and battery set sales for 1928. See page 142.*

*Will the screen-grid a.c. tube displace the 227 type as a general-purpose tube? See page 144.*

*All the facts about the 245-type tube. See page 167. How good servicemen have reduced the number of return no-charge calls. See page 145.*

*Technical data on Crosley, Silver, and Fada receivers. See pages 155, 161, and 171.*

# what they say

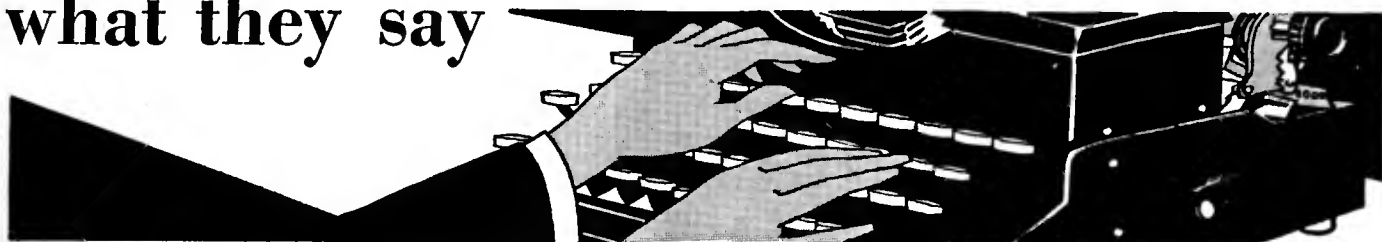

## The Trade-In Problem

THE DESIRABILITY of establishing a workable trade-in mechanism has long been appreciated by leaders of the radio industry. If such a system were developed it would be beneficial to the buyers and sellers of used sets, to radio dealers, and to manufacturers. A study of existing conditions, however, shows that there are many delicate problems which must be solved before the desired result may be obtained. In this connection, Curtiss Abbott, sales manager, Radio Division, National Carbon Company, makes a number of pertinent remarks:



### To the Editor:

Realization of the fact that trade-in value exists in his old set is a decided incentive for the owner to purchase a new and modern receiver. Therefore, a standardized trade-in policy would be of decided benefit to the industry. To this end the most obvious course is to establish a set of valuations for the more recent models of radio receivers.

The value of an old receiver is determined by three major factors: (a) its value in service to the buyer; (b) The degree of technical development involved in its design as compared with current models; and (c) the law of supply and demand.

In establishing trade-in values it is especially important that they be made as fair as possible. If used sets are priced too low it is a reflection on the products of past years and does not encourage trade-ins; excessive valuations are the same as reducing the prices of new receivers.

Giving the trade-in valuation of a receiver on the basis described above may often prove embarrassing to a dealer when faced with a customer to whom he sold the set originally three or four years back. In such cases it must be explained that half of the original investment was represented in the cost of accessories and supplies which are no longer of value, and then the dealer must point out how the improved appearance, selectivity, sensitivity, tone range, and operation of new sets affects the price of old sets. In addition, the improved convenience of new sets, namely, a.c. operation, has placed a very marked handicap on the value of old sets.

From the viewpoint of the dealer, the used set business is dangerous unless it is handled expertly. Giving substantially large allowances provided only a false stimulation of business and in extreme cases result in converting the stock of new models into one consisting of second-hand obsolete sets—and it is not a demonstrated fact that large numbers of used sets may be sold. At present the value of the turned-in product is depressed greatly by the superiority of current models, and great activity in the sale of old sets cannot be expected for two or three years, at which time a.c. sets will be turned in.

A possible solution of the dealer's problem is the establishment of regular channels for the distribution of old sets. At the present time it is customary for each dealer to dispose of his own second-hand stock, which is unsatisfactory in many cases because of the character of his clientele. On the other

hand, the situation might be improved by moving these sets to large cities where there are prospects of a type which would be more interested in the opportunity of buying old receivers at a low price.

H. CURTISS ABBOTT.

## Interference Hunters

MANY AGGRESSIVE dealers have found that the best way to create good will in their vicinity is to give complete service and this may be considered to include the elimination of interference throughout the town. This trend has created a demand for data on the design of interference-hunting receivers. RADIO BROADCAST has received several letters from dealers on this subject, and the one which follows is especially interesting as it outlines the essential electrical and mechanical characteristics of such a piece of apparatus.

### To the Editor:

While I cannot claim to be an expert in the field of interference hunting, I have done some experimenting—enough so that I know what an interference hunter should do, and how it should be built. Therefore, I am taking the liberty of mentioning a few of the points which I deem desirable:

1. The outfit should be complete with batteries and a self-contained loop, it should weigh not more than 20 pounds, and should be very compact, say, not more than 4 to 5 inches thick, perhaps 12 inches wide, and not exceed 14 to 15 inches in length. It should be carried by means of a shoulder strap, and it should be possible to operate it while it is being carried.

2. Interference hunters should have a minimum number of controls, one tuning dial, a volume knob, and a switch being an ideal combination. The tuning mechanism should offer enough resistance to changes so that its setting is not altered while being carried. The volume control should be across the output so that it may function as an audibility meter. An output meter is desirable for comparing signal intensities and should be included together with a push button for connecting it. A filament voltmeter and rheostat is also desirable in order to insure constant voltage during a test.

3. A set consisting of one stable r.f. stage, a fixed detector, and two a.f. stages is probably best suited for this work as it can be made compact and light in weight. C batteries should be used for the power supply to reduce the weight.



I also wish to point out a few of the disadvantages of the average interference hunter. In the first place, most of them are too heavy and have to be set down, opened, and adjusted before a reading can be taken. Usually the setting has changed or cannot be duplicated and, as a result, it is impossible to obtain an accurate comparison. With the receiver I have in mind, the operator can take a reading in one location, turn off the set, walk a block, and then take another reading without readjusting the dial. The output meter would indicate accurately the relative intensity at each location.

H. J. GODDARD.

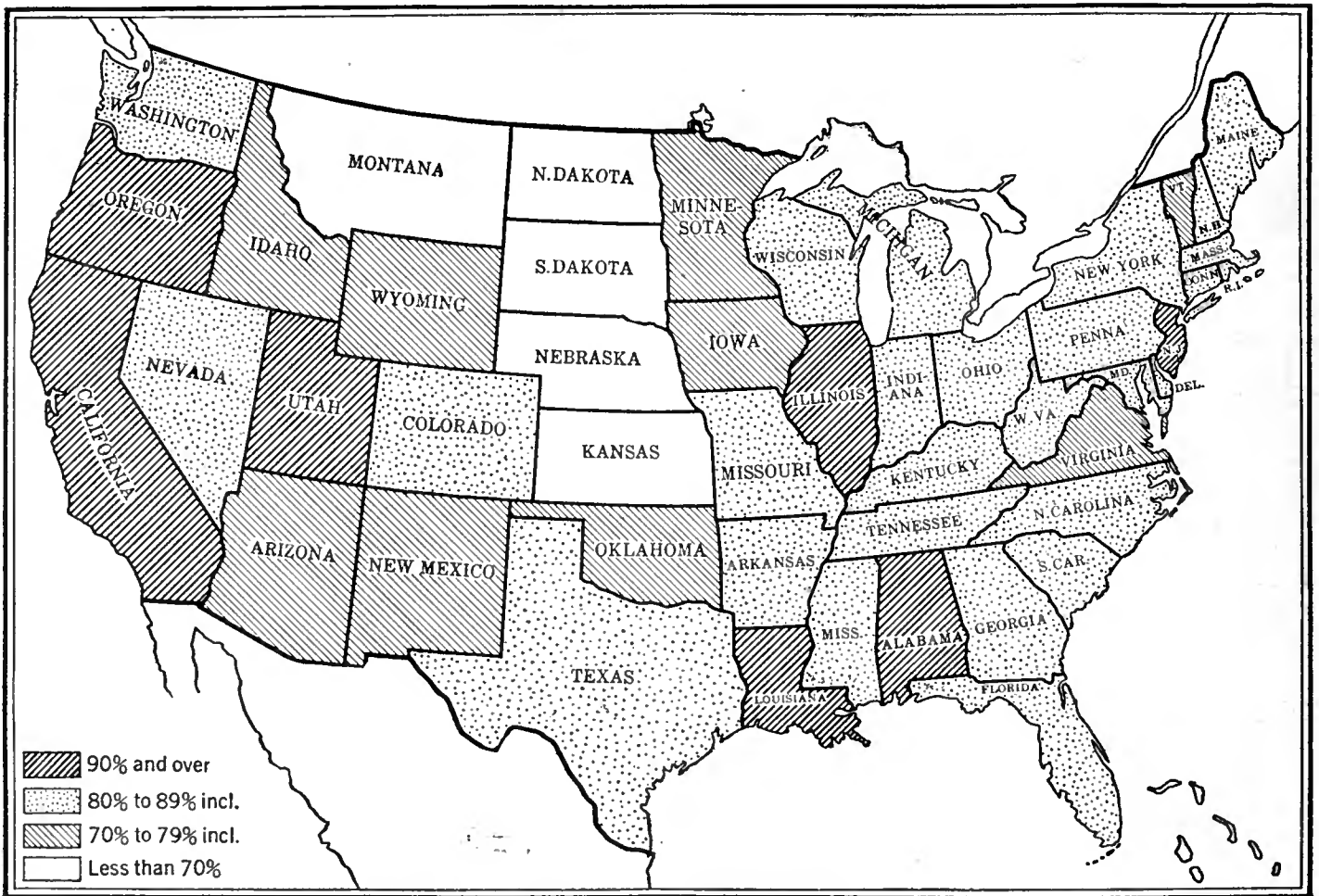

This map of the United States shows how the popularity of the a.c. receiver has increased in various sections of the country. The figures give the percentage of the total sales for the year of 1928 which is represented by the a.c.-operated receiver.

## How A.C. and Battery Set Sales Compare—I

# ANALYZING THE 1928 RADIO SURVEY

By T. A. PHILLIPS

Manager, Research Division, Doubleday, Doran and Co., Inc.

**T**HIS is the first of a series of three articles, analyzing the 1928 radio survey compiled by the Electrical Equipment Division of the Bureau of Foreign and Domestic Commerce. This survey is probably the most complete and important study concerning the radio market made this year. A casual inspection of the report fails to disclose the many significant facts lost in a great mass of detail. This series of articles will analyze the important facts.

A recent study made by the National Carbon Company discloses the fact that there are ten million homes that are not wired for electricity. Of this astounding number very few are not potential customers for radio sets. The following figures taken from the Bureau of Foreign and Domestic Commerce reports show the relative importance of these two types of receivers.

### Dealers' Stocks on Hand

	Battery Sets	A. C. Sets
January 1, 1928	72%	28%
January 1, 1929	20%	80%

### Number of Sets Sold

	Battery	A. C.
1927	74%	26%
1928	14%	86%
Last quarter 1928	11%	89%

### Sales By Population Groups, 1928

Population	Battery	A. C.
Less than 10,000	25%	75%
10,000 to 25,000	16%	84%
25,000 to 50,000	14%	86%
50,000 to 100,000	11%	89%
100,000 to 200,000	8%	92%
200,000 to 300,000	8%	92%
300,000 to 500,000	8%	92%
500,000 to 1,000,000	6%	94%
1,000,000 and over	11.6%	88.4%

### Discussion of Figures

**T**HE MAP of the United States on this page presents geographically the relative sales of battery and a.c. sets by states. The figures show that in Kansas, Nebraska, South Dakota, North Dakota, and Montana, battery sales still represent a significant portion of total number of sets sold. New Jersey, Illinois, Alabama, Louisiana, Utah, California, the District of Columbia, and Oregon are mighty poor sales territory for battery sets; more than nine out of every ten are a.c. sets, but even in these territories there are still an important number of homes not equipped with electricity. For example, in the District of Columbia 28,300 homes are unwired.

An analysis of the population groups shows that with the increases in population there is a relative decrease in the sale



of battery sets, with one exception. In New York, Philadelphia, Chicago, and the District of Columbia battery sets still find a good market. This may be accounted for by the fact that these cities are the stamping grounds of gyp dealers selling obsolete sets, and also because these large cities contain many homes supplied with direct current and houses in old sections which have never been wired.

A study of the sales for the fourth quarter of 1928 will show sales managers, those states where battery sets are still holding their own as well as the states where they are losing ground. The survey showed an average increase of 3 per cent. in a.c. sets over battery sets for the last quarter compared with the entire year. The following states showed less than a 3 per cent. increase:

- |                      |                |           |
|----------------------|----------------|-----------|
| Alabama              | Louisiana      | Oregon    |
| California           | Maine          | Tennessee |
| Colorado             | Missouri       | Texas     |
| District of Columbia | Nevada         | Utah      |
| Kentucky             | North Carolina |           |

DEALERS STOCK ON HAND

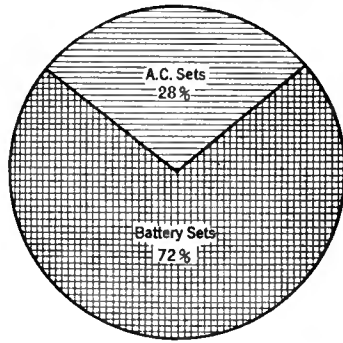

January 1, 1928

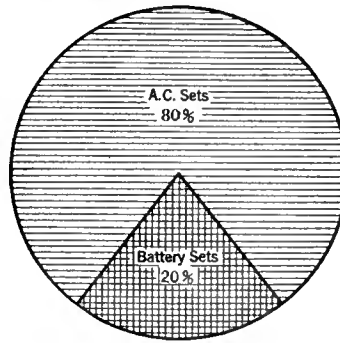

January 1, 1929

These charts show the extent to which the a.c.-operated receiver has replaced the battery set on the shelves of the average radio dealer during the year of 1928.

The following states showed the greatest increases:

- |              |     |
|--------------|-----|
| Arizona      | 12% |
| Idaho        | 7%  |
| Kansas       | 7%  |
| Maryland     | 8%  |
| New Mexico   | 7%  |
| North Dakota | 8%  |
| Ohio         | 7%  |
| Oklahoma     | 9%  |
| Pennsylvania | 8%  |
| Vermont      | 9%  |
| Virginia     | 13% |
| Wyoming      | 8%  |

The intelligent progressive dealer will not lose sight of the fact that regardless of his locality he is bound to pass up some good prospects if he does not have a supply of good battery sets. In addition to those radio users who are still unconvinced that the a.c. sets gives them as good, or better reception, there will always be an important number of homes not equipped to use a.c.-operated radio receivers.

Sales managers, using these figures as a basis, should make careful studies of their territories to determine those localities where battery sets must be sold, if radios are to be sold at all, regardless of the improvements or popularity of a.c. receivers.

Sales By States

(Grouped according to sales for entire year of 1928)

GROUP	ENTIRE YEAR, 1928		4TH QUARTER, 1928		GROUP	ENTIRE YEAR, 1928		4TH QUARTER, 1928				
	Battery	A. C.	Battery	A. C.		Battery	A. C.	Battery	A. C.			
GROUP A—OVER 90% A. C. SETS	District of Columbia	4%	96%	3%	97%	Mississippi	16%	84%	13%	87%		
	Utah	4%	96%	3%	97%	New Hampshire	16%	84%	13%	87%		
	California	5%	95%	4%	96%	New York	16%	84%	12%	88%		
	Louisiana	8%	92%	6%	94%	Kentucky	17%	83%	15%	85%		
	Alabama	9%	91%	7%	93%	Michigan	17%	83%	11%	89%		
	New Jersey	9%	91%	6%	94%	Maryland	18%	82%	10%	90%		
	Illinois	10%	90%	8%	92%	Missouri	18%	82%	17%	83%		
	Oregon	10%	90%	9%	91%	North Carolina	19%	81%	17%	83%		
						Wisconsin	19%	81%	14%	86%		
	GROUP B—80% TO 89% A. C. SETS	Arkansas	11%	89%	5%	95%	GROUP C—70% TO 79% A. C. SETS	Vermont	21%	79%	12%	88%
Connecticut		11%	89%	8%	92%	Virginia		23%	77%	10%	90%	
Maine		11%	89%	10%	90%	Arizona		26%	74%	4%	96%	
Florida		12%	88%	8%	92%	Idaho		26%	74%	19%	81%	
Massachusetts		12%	88%	8%	92%	Minnesota		27%	73%	19%	81%	
Pennsylvania		12%	88%	9%	91%	New Mexico		29%	71%	22%	78%	
Rhode Island		12%	88%	3%	97%	Oklahoma		29%	71%	20%	80%	
Tennessee		12%	88%	12%	88%	Iowa		30%	70%	24%	76%	
Georgia		13%	87%	9%	91%	Wyoming		30%	70%	22%	78%	
Texas		13%	87%	12%	88%	GROUP D—60 TO 69% A. C. SETS		Nebraska	32%	68%	26%	74%
Colorado		14%	86%	13%	87%			Montana	34%	66%	88%	72%
Indiana		14%	86%	11%	89%			Kansas	35%	65%	28%	72%
South Carolina		14%	86%	9%	91%			GROUP E—LESS THAN 60% A. C. SETS	North Dakota	43%	57%	35%
Washington		14%	86%	9%	91%	South Dakota			49%	51%	46%	54%
Nevada		15%	85%	15%	85%							
Ohio		15%	85%	8%	92%							
West Virginia	15%	85%	12%	88%								
Delaware	16%	84%	10%	90%								

BATTERY VS. A.C. SET SALES FOR 1927 AND 1928

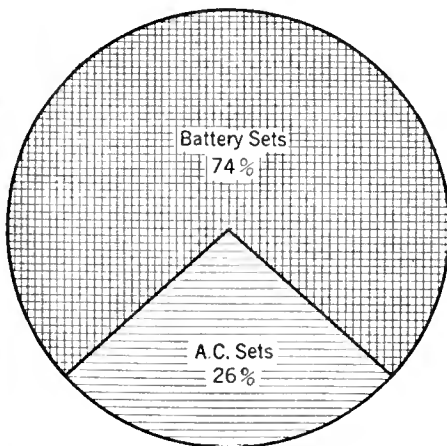

1927

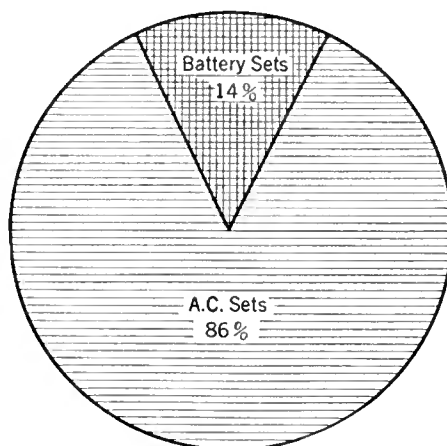

1928

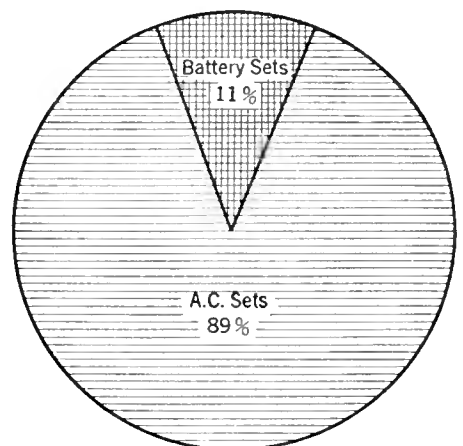

Last quarter 1928

Of the total radio receivers sold during the years of 1927 and 1928, and during the last quarter of 1928, these charts show what part of that number is represented by the sale of a.c.-operated receivers. It is interesting to note that even in the last quarter of 1928 the sale of a.c. sets is continuing to increase over the sale of battery sets.



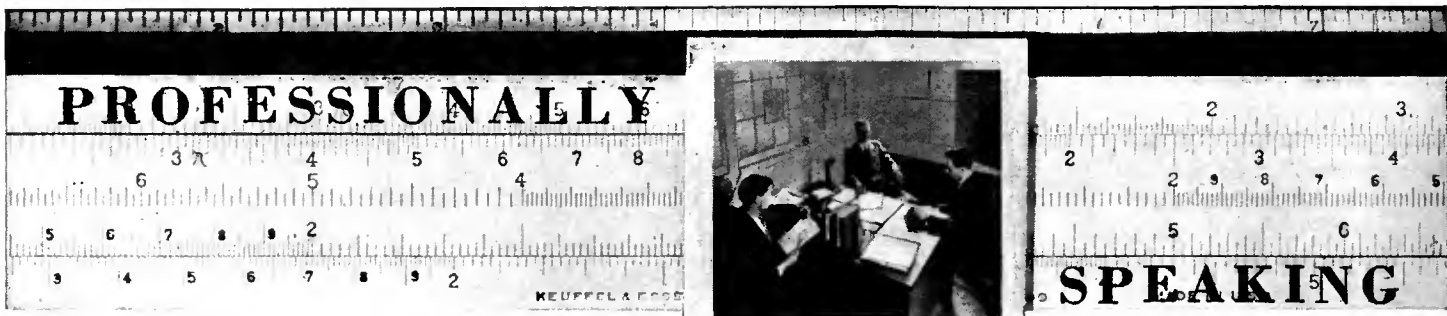

**Needed—a Simple Battery Set for the Farmer**

It is said that there is a potential market in this country for nine-million radio receivers for homes in which there are no power wires. These are rural homes, and homes far enough away from power lines to make it uneconomical to extend wires to them. It is in these nine-million homes that we believe a manufacturer with a good three- or four-tube receiver operating entirely from batteries and doing it economically would do not only a remarkable piece of business, but a great public service too. Using one screen-grid tube of the 222 type as r.f. amplifier, another screen-grid tube as detector (which will be about five times as sensitive as the 201A), and a power tube of the 112 type, the total plate current will be of the order of 15 milliamperes and the filament current required would be from 0.4 to 0.5 amperes at 5 volts.

The difficulty is that people have been educated to want greater power output than the 112 tube can deliver. The solution, which has been found in England and on the Continent, is the pentode tube, a tube with five elements instead of three or four as is common practice at present. It is an efficient power tube, consuming less filament power than most of our battery-operated tubes, requiring only moderate plate current at moderate plate voltages, and needing only a small input signal in order to deliver a moderate power output.

Elsewhere in this issue (page 154) will be found some technical data on how much power one can obtain from a tube of this type. These curves and independent measurements in the Laboratory indicate that a pentode will supply a power output equivalent to that obtainable from a 171-type tube at a plate potential of 180 volts—which until a year ago satisfied nearly every one. Furthermore, the plate current drain of a pentode is not over 12 milliamperes.

Now let us see what this means. If the pentode were connected to the detector through a 2:1 transformer the detector would have to put out from 2.5 to 8 volts (depending upon the tube) to load it up. A fully modulated signal of 0.25 volts (r.f.) will produce an audio voltage of 0.5 volts across 50,000 ohms in the plate circuit of a 301A acting as a grid leak and condenser detector. If the 322 is five times as sensitive it will deliver, on the same input, an output of 2.5 volts and will require about 0.75 volts to deliver the required 16 volts.

In a single stage of screen-grid amplification a gain of 50 can be obtained, and if the antenna is series tuned and coupled to the screen-grid amplifier another voltage gain of 15 can be obtained, making the voltage step-up from antenna to grid of detector  $50 \times 15$  or 750, so that a field strength of approximately 80 microvolts per meter into a 4-meter antenna would deliver 700 milliwatts into the loud speaker. This is the sensitivity of receiving sets of a year ago.

Such a receiver would deliver signals of almost as good fidelity as receivers of a year ago. It would be somewhat deficient in low frequencies, and would not have particularly good discrimination against unwanted stations. It would have,

perhaps, 30-kc. selectivity. The entire receiver, including loud speaker—as is conventional practice now—would be provided by the same manufacturer and so the farmer, or dweller far from power lines, could get his economical radio all in one package.

**The General-Purpose Tube of the Future—the 224**

THE FACT that the screen-grid tube is the tube par excellence for radio-frequency sockets, and that it can be used as a detector, coupled with the general use of single-stage a.f. amplifiers leads us to wonder if the a.c. screen-grid tube will not become the general-purpose tube of the future.

As a detector of the C-bias type, the 322-type tube is about three times as sensitive as the 327-type tube and the 324 is about ten times as sensitive as the familiar heater-type three-element tubes now employed in the detector socket of all a.c. receivers.

An article is being prepared for RADIO BROADCAST which will show the characteristics of the new a.c. screen-grid tubes when used as detectors, and data now at hand indicates that an audio-frequency output of sufficient voltage to load up a 171- or 245-type tube may be obtained with an r.f. input of from 2 to 3 volts.

Now let us look at this rather critically. Such a tube will have to be coupled to the grid of the following tube either through a resistance or a choke because of its own very high plate resistance. A 500-henry choke or a 200,000-ohm resistor could be used, but the latter would make it necessary to supply more voltage to the ground end of the coupling resistor than is used in the power tubes—which we shall assume will be the 245 type, for it appears to be the power tube for nearly all home receivers.

It looks, then, as though the screen-grid detector must be coupled to the following power tube through a fairly low-resistance high-inductance choke of low distributed capacity. If shunted by a 250,000-ohm resistor and by a capacity of not over 100 mmfd., a 500-henry choke would provide a characteristic as good as many of the best a.f. amplifiers now being put into commercial radio receivers.

The disadvantage of resistance or choke coupling would be the fact that a push-pull amplifier could not be used, and it seems to be the tendency at the present time to make the final stage push pull. If, then, another a.f. stage were inserted between the screen-grid detector and the power tube, a lot of a.f. gain would have to be thrown away in order to enjoy the advantage of push pull, namely freedom from hum on a.c. operation, cheapness of output transformer, and freedom from overloading difficulties.

With one or two screen-grid tubes as r.f. amplifiers, a screen-grid detector, and a power tube, with pre-selecting ahead of the r.f. amplifier, we ought to have a pretty economical set to build, operate, and keep in order. And there you are. Will the screen-grid tube become the general-purpose tube of the future? Our guess is as good as any one's.

## VALUE OF FUNDAMENTAL KNOWLEDGE

By JOHN S. DUNHAM

QRV Radio Service, Inc.

A GREAT DEAL of discussion has arisen about the questionnaire published in the April, 1929, RADIO BROADCAST which is used by the QRV Radio Service, Inc., as an examination of applicants for the position of radio servicemen. Insofar as we have been able to ascertain it, the consensus is that the examination is more difficult than would be necessary to determine the ability of a good serviceman. We have talked with a considerable number of representative service managers and servicemen, most of whom feel that a good serviceman need not know enough to obtain a passing mark on that examination. Some few of the service managers with whom we have talked very heartily approve of the test and there have been a few who thought such an examination might justifiably be made even more difficult; but those who entertained that opinion have been distinctly in the minority.

The purpose of this article is to illustrate the value of the knowledge possessed by a serviceman who could obtain a good mark on that test. We shall attempt to do that by taking each question or group of questions separately and discussing just how the knowledge required to answer that question can be of practical aid in the servicing of broadcast receivers.

### Service Standards

IT IS our opinion that one of the greatest troubles with the service game to-day is lack of realization on the part of the average serviceman that servicing broadcast receivers is a difficult technical pursuit, requiring both general and specialized electrical training. Because the average serviceman does not realize that fact, he is, as a rule, making little effort to provide himself with the technical knowledge pertaining to his work, without which he can never become a thoroughly efficient worker in the field he has chosen. It is our belief that the generally accepted standard of knowledge possessed by men who are considered "good" servicemen has been far too low, simply by virtue of ignorance on the part of the average employer of servicemen that there are men who know a great deal more about their work, and that an intelligent serviceman can be trained to know more—and thereby become more efficient—than has been generally thought necessary. It has been our experience that a man who cannot make a grade of at least 70 per cent. on our examination has not enough general knowledge of broadcast receivers to be a successful serviceman

without a great deal of further training. And by a successful serviceman we mean a man whose work is not followed by a number of return calls, within two weeks, greater than 5 per cent. of the calls made by that man. The return call records of the work of three men employed by QRV, compared with their marks on the test, illustrates the point very clearly. One of these men—who is no longer with us—obtained an examination mark of 60.5 per cent. Over a period of four months, his work was followed by 14.4 per cent. no-charge return calls. The second man had a mark of 81.5 per cent. His work for the same period was followed by 4.3 per cent. return calls. The third man achieved a mark of 96.75 per cent. His work for the period was followed by 0.7 of one per cent. return calls. Each of the three men made approximately the same number of calls during that period.



This motorcycle service and delivery truck is cutting down service costs for Atchison's Radio Shop, Philadelphia, Pa.

### Replacing Rheostats

SOME of the servicemen who thought the examination to be of value, taken as a whole, are of the opinion that the portion of it in which we attempt to ascertain the knowledge of simple fundamentals possessed by applicants is an entirely unnecessary requirement. It is our opinion, and it is well borne out by long experience, that a thorough knowledge of the simple d.c. and a.c. circuits is exactly as important a part of the serviceman's working equipment as is his knowledge of how to locate an open in a plate circuit. For example, let us assume the case of a burned-out rheostat in an old set, the manufacturer of which is no longer in existence and for which no parts catalogue is obtainable. In such a case it is extremely rare to find the resistance value of that rheostat marked on it. The serviceman is faced with the problem of determining the proper value of resistance with which the damaged rheostat must be replaced. If he does not possess a working knowledge of Ohm's law, the only method by which he may determine the proper size of rheostat to get is to remove whatever remains of the resistor element of the damaged rheostat and take it with him on a time-wasting search for a new rheostat, the size and length of whose wire appears physically to match that of the old one.

On the other hand, if he is familiar with Ohm's law he will take out his pencil and set down the familiar fact that  $R = E/I$ . He will then multiply the filament current drawn by one tube by the number of tubes controlled by that rheostat, to get the total amount of current through the rheostat. He

knows that the voltage supplied by the storage battery is 6 volts, that to be supplied at the tubes is 5 volts, and he knows, therefore, that the minimum drop which must be caused across the rheostat by the current taken by those tubes must be one volt. But he knows also that it would be advisable to be able to reduce the voltage at the tubes to about 2 volts so that the maximum drop which will be necessary across the rheostat is 4 volts. Knowing the current through the rheostat and the maximum drop required he can substitute those values in the simple formula and very quickly determine the resistance value of the needed rheostat. Knowing that value and the value of current which the rheostat must carry safely, he can telephone an order to his distributor for a new one and thereby save himself and his organization the time which he would otherwise waste in hunting for a rheostat to match the old one. If the type of replacement which he orders is rated in watts instead of in current carrying capacity, he can calculate the wattage required by substituting the voltage and current values in one of the two simple Ohm's law formulas,  $W=EI$ , or  $W=I^2R$ . The time required for those computations should not exceed five minutes, but the time required in searching for a physical mate of the damaged rheostat may very easily extend into hours.

Exactly the same considerations apply in most instances when the replacement of any fixed or variable resistor is necessary in sets for which no parts catalogues are in existence, or, if in existence, are difficult to obtain. The experienced serviceman knows that there are literally hundreds of models of receivers in use to-day for which such parts lists cannot be obtained. He also knows that in most cases neither the resistance, current, nor wattage values are marked on the parts which need replacement. For that reason alone the few hours that it would take the serviceman to learn the fundamental formulas of Ohm's law would, generally speaking, save him at least an equal number of hours *monthly*, and often *weekly*.

### Measuring Other Resistors

THERE ARE a good many times when it is impossible to match resistors by their physical appearance. It is usually possible to do so with variable resistors of low value, such as filament rheostats and wire-wound potentiometers of less than 1000 ohms, but it is rarely possible to do so with any other types of resistors, either variable or fixed. Fixed resistors such as those used in voltage-divider systems are usually covered with protective enamel so that the wire itself cannot even be seen. Resistors of higher orders of value than are generally employed in divider systems, such as grid-leaks which run up into the hundreds of thousands and millions of ohms, are usually not wire wound. Even if they were wire wound and the wire exposed, the size of wire used would be so small that it would be impossible to compare its resistance with that of another resistor simply by visual inspection. In any such case the only method by which a new resistor of the proper value can be selected in the absence of a parts list is by arithmetical calculation of the value needed in that particular part of the circuit. The serviceman who is not able to perform the necessary computation can be more hopelessly lost than a child separated from its parents at Coney Island on a hot

Sunday, for there may be no kindly policeman around to guide him.

Let us take another example of a service problem that arises frequently with sets supplied from either alternating- or direct-current lighting circuits. In both of those types we have voltage dividers usually consisting of wire-wound resistors upon the value of which and the current through them depend the voltages applied to the plates of the tubes. If the value of one of those resistors changes in use the voltage applied to the tubes will no longer be the correct value. When servicing a set, if the  $E_p$  at the tube or group of tubes with common plate supply is incorrect, but the  $I_p$  is normal, the voltage supplied to the divider itself is normal, and there are no incorrect conditions elsewhere in the set, it is highly probable that the value of the resistance providing the drop for that tube or group of tubes has changed. There are two ways in which the correctness of that supposition may be determined. One is by substituting a new resistor of known value for the suspected resistor and then determining by test whether the  $E_p$  has returned to normal. That method can be used only if the serviceman happens to have with him the proper replacement unit for that particular divider system, which he is unlikely to

accurately determine the amount of variation from the correct value, and it also may be performed readily without equipment other than the usual good set analyzer. The man equipped with Ohm's law in that case saves time and he obtains definite knowledge which the man who is not so equipped could not obtain. That ability to calculate the value of a resistance is even more important when servicing some of the older socket-powered receivers than it is with the usual modern set, because some manufacturers were guilty of employing voltage-divider resistors which were not wire-wound (of the grid-leak type) which often do not have a sufficiently high wattage rating, with the result that their values are subject to wide changes.

### Series and Parallel Resistors

SUPPOSE IN the shop it is found that the value of a divider resistor in a power pack has risen above its correct value to an extent which requires that it be replaced. Suppose also that no new resistor of the proper value is at hand, but there are in the shop a miscellaneous assortment of resistors of suitable wattage rating, which might be used for replacement. If the serviceman does not know how to calculate the value of resistance obtained by connecting resistors of known values in series or in parallel he will be unable to obtain the value he desires to use except by a lengthy and haphazard process of trial. If, on the other hand, he knows the two simple formulas for calculating the resultant value of both series and parallel arrangements, he can quickly, readily, and accurately pick out from his miscellaneous assortment a combination of resistors which not only will give him the desired value for replacement, but will also employ for that purpose the smallest number of those resistors which is necessary. The process of determining whether the miscellaneous resistors in the shop will be suitable and of designing a combination to give the proper value is one which may be performed in a very short time, whereas the trial method without the use of formulas can consume a very long time.

### Capacity Determinations

THE SAME considerations apply to the value of knowing the formulas for series and parallel capacities. For example, suppose that the familiar ailment of a broken-down filter condenser has occurred and the only capacities which are available for replacement of that condenser are of different values than the one required. Assume that the value of the condenser which has broken down is 4 mfd. and the serviceman has available in his shop, or with him on the job, two capacities of 2 mfd., each of which would be suitable for replacement in the filter in so far as their voltage rating is concerned. If the serviceman does not know the effect on total capacity of either series or parallel connection of capacities, and if he happens to know that connecting two resistances in series increases the total resistance in that circuit—which he might know without being familiar with the formula—it would be logical to assume that he would connect those two capacities in series in the belief that the total capacity obtained would be the sum of their separate capacities, or 4 mfd. Actually, of course, the total capacity obtained would be 1 mfd. and in most cases when the set was con-

## FREQUENTLY USED FORMULAS

The formulas given below are those which the serviceman may use daily in his work. Each of these should be memorized so that they become a practical part of his working knowledge of electricity.

### Ohm's Law (Three Versions)

$$\text{Volts (E)} = \text{Amperes (I)} \times \text{Ohms (R)}$$

$$R = \frac{E}{I} \qquad I = \frac{E}{R}$$

### Power in Watts (Three Formulas)

$$W = I \times E \qquad W = \frac{E^2}{R} \qquad W = I^2 R$$

### Condensers in Parallel

$$C_{\text{TOTAL}} = C_1 + C_2$$

### Condensers in Series

$$C_{\text{TOTAL}} = \frac{C_1 \times C_2}{C_1 + C_2} = \frac{1}{\frac{1}{C_1} + \frac{1}{C_2}}$$

### Resistors in Parallel

$$R_{\text{TOTAL}} = \frac{R_1 \times R_2}{R_1 + R_2} = \frac{1}{\frac{1}{R_1} + \frac{1}{R_2}}$$

### Resistors in Series

$$R_{\text{TOTAL}} = R_1 + R_2$$

have in most cases because the values and physical sizes of such resistors vary so widely that it would be necessary for a man who was performing service on all makes of sets to carry an entirely impractical number of such units with him.

The other method is to determine the exact value of the suspected resistor without removing it from the circuit, by the use of Ohm's law. Measuring the current through the resistor by inserting a milliammeter in series with it and measuring the voltage across it and the milliammeter at the same time, substituting the values obtained in the Ohm's law formula ( $R=E/I$ ), and solving for the value of R, is an operation which can be accomplished in less time than would be required to remove the resistor and connect a new one in its place. That method not only saves time but it

nected up again the 60-cycle hum evident in the loud speaker would be greater than its previous normal value, and in some cases the output voltage of the filter would be lower than normal—depending upon the position of the condenser in the circuit. The serviceman, still assuming that he had replaced the filter condenser with the proper value of capacity, would not know the reason for the increased hum or the lower voltage and might spend fruitless hours in endeavoring to ascertain the cause. On the other hand, if that serviceman were familiar with the two simple formulas for determining the total capacity of series and parallel arrangements, he would have connected the 2-mfd. capacities in parallel, thus obtaining the total capacity of 4 mfd. and when the equipment was connected up again for trial the hum would not be greater than it was before, and the voltages would be correct, assuming all other conditions to be normal.

Assuming the same trouble as that described in the preceding paragraph, suppose that the only capacities available for replacing the 4-mfd. filter condenser were two capacities of 8 mfd. each, but the voltage rating of which was only half that required in the filter system at that point. The same serviceman would assume that the total capacity obtained by connecting those two capacities in series would be 16 mfd. Without even elementary knowledge of fundamental laws he might also assume it to be impossible to use those condensers because of their low voltage break-down rating. The serviceman who was familiar with the series and parallel capacity formulas and who also possessed a general knowledge of a.c. and d.c. phenomena would know, as illustrated in the preceding paragraph, that the sum of the two 8-mfd. capacities in series would be 4 mfd. and he would also know that the voltage drop across each of the two equal capacities would be approximately half of the total voltage across both of them (assuming the resistances of the two capacities to be approximately equal). The latter serviceman would insert those two condensers, knowing that they would meet the requirement, whereas the former serviceman, because of his lack of even elementary fundamental knowledge, would not use those two suitable replacement units and would keep the owner of the set waiting unnecessarily while he obtained a single 4-mfd. unit, and he would unnecessarily continue to carry in stock the two 8-mfd. units which might have been used up. These examples of the value of some knowledge of fundamentals are just a few picked at random for illustration, and enough similar illustrations of different cases where such knowledge is of very real value to the practicing serviceman could be given to fill many pages of this magazine. The money value of the time saved in actual practice by the serviceman possessing such knowledge is so much greater than the money value of the time necessary to acquire that knowledge that the returns on such an investment are well worth while.

### A.C. Knowledge Essential

THE QUESTIONS under fundamentals in the examination referred to deal only with d. c. except for the last question on capacities. However, it is important and is

becoming increasingly so because of the increasing use of a.c.-powered sets, for the serviceman to have a working knowledge of fundamental a.c. phenomena. In the examination we are now preparing with which to determine the knowledge of applicants who come to us this Fall and which will replace the one under discussion, there will be a number of questions devoted to a.c., under the heading of fundamentals. All signal currents, both radio frequency and audio frequency, are alternating. The filament currents employed to heat the tubes in modern receivers are alternating. It is alternating current which is rectified to direct current for supplying the plate currents used by the tubes. The only direct current used in

impedance of approximately 4000 ohms at 1000 cycles, whereas the input impedance of the average dynamic speaker is of the order of about 10 ohms. Had that man been possessed of working knowledge of fundamental electrical laws he would have known that maximum transfer of energy is obtained when the impedance of the load matches the output impedance of the transformer or other supply to which the load is connected, and that the transfer of energy falls off badly as the load impedance is decreased. He would also know that there is a modification of that rule which applies to the transfer of energy in the audio circuits of radio receivers. The modification is that the greatest amount of undistorted energy is transferred when the load impedance is approximately twice that of the impedance out of which it works. The serviceman described who did not know those things spent a large amount of time trying to discover the cause of his trouble, with the sole result that he became thoroughly disgusted with the dynamic loud speaker and pronounced it to be defective, with no basis for that conclusion other than the fact that it did not work. Had he known those a.c. laws pertaining to the transfer of energy he would have procured, before he attempted to connect the dynamic loud speaker to his set, an output transformer with a sufficiently high step-down turns ratio so that, while its primary impedance would still match the output impedance of the last tube, the impedance of its secondary would be equal to, or less than, the input impedance of the loud speaker at 1000 cycles.



*A well-equipped service department plus servicemen carefully selected for their ability to create good will is one of the outstanding reasons for the success of Lancaster Radio Sales and Service, Philadelphia, Pa.*

the modern radio receiver (other than those sets designed for operation from d.c. lighting circuits) is that which supplies power to the plate circuits of the tubes. All the rest is a.c. It would seem logical, even to a layman, that it would be worth while for a man whose vocation is the servicing of such receivers to know something of the fundamental phenomena of the currents with which he is constantly working. If a doctor whose business it is to work on a mechanism of arteries and veins carrying vital blood, which are comparable to the circuits of a radio receiver carrying vital electric currents, knew nothing of the fundamental laws governing the action of those vital currents in the human body, it is obvious that it would be impossible for him to succeed in his profession. Exactly the same conclusion may be drawn about the serviceman who knows nothing of the laws governing the action of the currents in a radio receiver.

A very good example of the value of such knowledge was brought strongly home to us recently. A serviceman of our acquaintance purchased a dynamic loud speaker which did not have an input transformer with it. He connected it to the secondary terminals of an output transformer following the usual 171A-type tube, fully expecting improved results over the cone loud speaker he had been using. Naturally the results were very poor, by virtue of the fact that the impedance of the secondary of the usual output transformer is designed to work into a loud speaker

### Higher Standards

STANDARDS of service are slowly but surely being raised. Service organizations discovered long ago that there is a very definite relationship between the extent of knowledge, theoretical as well as practical, possessed by a serviceman and the percentage of return calls with which it is necessary to follow that man's work. Dealers who realize the dollar and cents value of giving good service to their customers are discovering that the average servicemen who apply to them for positions in their service departments are not capable of giving their customers really satisfactory service. They are also discovering that the reason the average serviceman cannot perform efficient service is that he has not had adequate training for the work at which he professes to be an expert. A few dealers are learning gradually that there are, among the many servicemen who apply to them for work, a few here and there who have actually *studied* radio, and from their experience with the few men of that type whom they have been able to employ they are waking up to the fact that *only* such men are a profitable investment in service personnel. It behooves the servicemen who desire to continue servicing broadcast receivers as a means of livelihood and who have enough ambition to desire to increase their earnings by means of increasing their efficiency, to see the handwriting on the wall and realize that in order to learn thoroughly the subject of servicing radio receivers it must be studied with the same diligence with which one would study any other highly specialized technical activity.



# IN THE RADIO MARKETPLACE

News, Useful Data, and Information on the Offerings of the Manufacturer

## New Receivers Announced

**T**HE WARE MANUFACTURING CORPORATION is the maker of a new receiver incorporating a hand-pass amplifier to obtain sharp tuning without sacrificing the fidelity. The r.f. amplifier uses screen-grid tubes and the output stage employs a 245-type power tube. The table model lists at \$195 and the console, which contains a dynamic loud speaker, retails at \$125.

THE C. R. LEUTZ COMPANY has announced the Seven Seas Console Set. The set consists of three stages of tuned r.f., a detector, and one stage of a.f. Screen-grid tubes are used in the r.f. stages and two 210-type tubes in push pull are employed in the output. In the console is incorporated a dynamic loud speaker.

RADIO RECEIVERS for operation on 32-volt farm-lighting plants are being manufactured by the Federal Radio Corporation. The farm-lighting system supplies current for the filament and ordinary B batteries must be used for the plate supply. These sets are completely shielded and use the same circuit as is incorporated in the Federal sets, models E and F, designed for 110-volt a.c. operation. Prices range from \$100 to \$325.

THE FEDERAL ORTHOSONIC Model M is an all-electric receiver using five 227-, two 245-, and one 280-type tubes. The receiver is shielded thoroughly and each plate lead to the r.f. tubes is filtered by resistors and by-pass condensers. The set is equipped with a "timber" control which permits the user to vary, to some degree, the characteristics of the audio system.

THE CONTINENTAL RADIO CORPORATION has announced three new designs of "Star-Raider" receivers, models n-20, n-30, and ap-40. The Technidyne circuit is used in a chassis consisting of seven 227-type tubes, two 250-type power tubes, and two 281-type rectifier tubes. An automatic line-voltage regulator is included in the power supply. The set has two dials, one a station selector and the other a volume control. A phonograph pick-up jack is provided. All models use a 14-inch dynamic loud speaker.

THE AMERICAN BOSCH MAGNETO CORPORATION announces three new receivers which have been designed to use the a.c. screen-grid tube. All three of the sets will use the same chassis which employs three screen-grid tubes as r.f. amplifiers, one 227-type tube as a detector, two 245-type tubes in push pull, and a 280-type rectifier. The table model is reported to list at \$119.50, the combined set and loud speaker console at \$168.50, and the De Luxe highboy at \$240.00.

## Miscellaneous Apparatus

**T**HE MASTER ENGINEERING COMPANY, of Chicago, is the maker of a complete series of line-voltage control devices. Units with the capacity of either 60 watts or 100 watts may be obtained. The 60-watt size being generally suitable for use in such sets as the Atwater Kent, Radiola 18, Crosley, Philco, etc.

The 100-watt size is especially adapted for use with radio sets utilizing dynamic loud speakers such as the Majestic, Radiola 62, Sparton, Zenith, Kolster, Fada, etc. The 60-watt unit sells for \$2.50, and the 100-watt unit for \$3.00.

A VARIABLE RESISTANCE capable of handling 20 watts and having a range of from about 40 to 10,000,000 ohms is being made by the Pilot Electric Manufacturing Company. This new resistor, known as the "Resistograd," will withstand potentials as high as 500 volts. The retail price is \$1.00. Other resistors are made in sizes as follows: 0-50,000 ohms, 0-100,000 ohms, 0-200,000 ohms, and 0-500,000 ohms. These latter resistors will carry 0.125 watts and sell at \$1.50.

THE DURILIER type 688 filter condenser is rated at 2000 volts d.c., 1500 volts a.c., and is designed for use particularly in conjunction with the a.c. mercury-vapor rectifying tube which is frequently used in small transmitters.

ELECTRAD, INCORPORATED announces two new products, a 5-watt high-resistance volume control and a complete line of wire-wound covered resistors. The new volume control measures  $2\frac{3}{8}$  by  $2\frac{1}{4}$  by  $\frac{3}{8}$  inches deep and is one-hole mounting. It incorporates a graphite resistor element fused to an enamel base. The volume control may be made in any desired range and either of uniform resistance or tapered to meet specifications.

The new Electrad fixed resistors are made in various sizes from 7.5 to 100 watts with various values of resistance up to approximately 175,000 ohms. The nickel-chromium alloy which is used for the re-

sistance wire is wound on a piece of refractory tubing and is covered with an elastic enamel.

NEW TYPE volume controls, balancing condensers, and small molded condensers are being made by the Polymet Manufacturing Corporation. The volume controls are made in various values of resistance. The molded condensers contain two insulated mounting holes and measure  $\frac{1}{4}$  by  $\frac{1}{8}$  by  $\frac{1}{2}$  inch.

A UNIQUE "Rainbow" dial is being manufactured by the National Company. As the knob is turned various colors in turn illuminate the face of the dial. Other new products announced by this company are a tuner, type MB-29, which uses four a.c. screen-grid tubes and the new "Velve-tone" amplifier. The latter device is completely a.c. operated and uses two 245-type tubes, one 227-type tube, and one 280-type rectifier. Another new product is the National Polarizer, a unit designed to supply voltages to condenser-type loud speakers. It lists at \$12.50.

A DYNAMIC LOUD SPEAKER is being made by the Transformer Corporation of America. The diaphragm is one piece of large diameter. Special construction permits the elimination of the suspension spider at the apex of the diaphragm. These loud speakers are furnished to manufacturers with and without rectifiers or transformers. Special field coils are supplied to meet individual requirements.

A NEW DEVICE, the Plugairial, is announced by the Consolidated Corporations of Chicago. The device is designed to plug into a light socket and connection is provided for the antenna. List price: 85¢.

## Items of Interest

**T**HE ALUMINUM COMPANY OF AMERICA is prepared to furnish aluminum sheet of high purity, ordinary commercial purity, and in the form of various strong alloys. This material finds frequent use in radio receiving sets. The company also manufactures aluminum foil for use in fixed condensers. Complete data on the products of this company may be obtained from any of their local sales offices located in the following cities: Albany, N. Y.; Boston, Mass.; Buffalo, N. Y.; Chicago, Ill.; Cincinnati, Ohio; Cleveland, Ohio; Detroit, Mich.; Indianapolis, Indiana; Kansas City, Mo.; Milwaukee, Wis.; Newark, N. J.; New York, N. Y.; Philadelphia, Pa.; Pittsburgh, Pa.; San Francisco, Calif.; St. Louis, Mo.; Toledo, Ohio; and Washington, D. C.

A MICROPHONE for use in broadcast stations is being distributed by the Gotham Engineering and Sales Company. It is of the two-button type with a solid back and uses a stretched duraluminum diaphragm. The unit lists at \$75, or complete with ring desk mount, covers, and cord at \$98.50.

A RADIO TEST PANEL for jobbers and dealers has been announced by the Jewell Electrical Instrument Company. This new model No. 581 panel makes possible the



The new Bosch console receiver shown above has three screen-grid tubes and a dynamic speaker connected to the output of a push-pull stage. The cabinet has sliding doors.



rapid checking of both old and new receivers. The panel contains seven instruments as follows; 0-7.5 volts d.c., 0-75 volts d.c., 0-150-300-750 volts d.c., 0-15-150 milliampères d.c., 0-4-8-16 volts a.c., 0-150-750 volts a.c., and 0-1.5-15 microfarads. The latter instrument measures capacities.

THE STERLING MANUFACTURING COMPANY'S new tester, type R-522, makes possible the complete checking of all types of a.c. and d.c. tubes and sets. It contains six meters with no more than two scales on any one meter. Binding posts are provided so that the meters may be used as separate instruments if desired. The entire instrument is supplied with a morocco leather-grained case. The retail price is \$40.50.

Personal Notes

H. P. DAVIS, vice-president of Westinghouse and formerly in charge of manufacturing operations, will devote his entire time to the activities of Westinghouse in the radio field. J. S. Trittle, formerly manager of the merchandising department, at Manfield, Ohio, will succeed Mr. Davis as head of manufacturing operations. Mr. Davis was graduated from Worcester Polytechnic Institute and has been with the company since 1891.

THE BOARD OF DIRECTORS of Kolster is headed by Rudolph Spreckels, chairman; other members are R. O. Bokee, Frederick Dietrich, Herbert H. Frost, Frank H. Hitchcock, M. C. Rypinski, Robert Hayes Smith, Howard Spreckels, and Ellery W. Stone. Officers of the company are: Ellery W. Stone, president; Frederick Dietrich, vice-president; Herbert H. Frost, vice-president; Howard Spreckels, vice-president; Robert Hayes Smith, vice-president; Augustus Taylor, vice-president; Henry C. Lang, secretary and treasurer. Saint G. Lafitte, who comes from the Spreckels companies in California, was chosen executive vice-president.

A. E. EMERICK has been appointed manager of the Edison Distributing Corp., 500 Elm St., Dallas, Texas.

W. C. EVANS, formerly assistant manager of radio operations for Westinghouse, has succeeded C. W. Horn as manager. Mr. Evans was formerly manager of KYW in Chicago and began his radio career at the age of 15 as radio operator aboard a Great Lakes ship. Immediately before his new appointment he was working closely with RCA Photophone in the sound motion picture field.

C. W. HORN, formerly manager of radio operations for Westinghouse, has joined the National Broadcasting Company as general engineer. He recently returned from a trip abroad with M. H. Aylesworth, president of N. B. C., where an inspection of foreign broadcasting was made.

BYRON B. MINNIUM is now chief radio engineer with Stewart Warner. Mr. Minniun, a graduate of the engineering school, University of Cincinnati, was, like many others now in various branches of engineering work, formerly a ship radio operator. He pounded brass aboard Great Lakes passenger vessels for many years. He is respon-



The new Eveready Model 32 console receiver. The compact cabinet is made of selected walnut.

sible for the design of the Stewart Warner "balanced bridge" circuit used in their line this season.

THE TRIAD MFG. CO., Pawtucket, R. I., announce the appointment of V. K. Wilson as assistant sales and advertising manager. Mr. Wilson comes from the Tower Mfg. Co., Boston, where he held a similar position. H. H. Steinle is vice-president and general sales manager of Triad.

GOLD SEAL, makers of radio tubes under the same name, announce the appointment of Frederick Holborn, Ph. D., as chief engineer. Dr. Holborn studied physics at Frielburg, Goettingen, and Wuerzburg and received his Ph. D. at Jena. He has been with DeForest, Westinghouse, and Kolster in recent years in research work.

PAUL J. MCGEE, formerly of Zenith, is now service manager of Edison Radio. While with Zenith, Mr. McGee accompanied the MacMillan Arctic expedition in 1925 as radio operator.

TWO NEW directors have been added to the board of directors of the Jenkins Television and the DeForest Radio Company. They are Robert A. Gardner of Mitchell, Hutchins & Co., Chicago, and Chas. G. Munn, president, Reynolds Spring Co., Jackson, Mich.

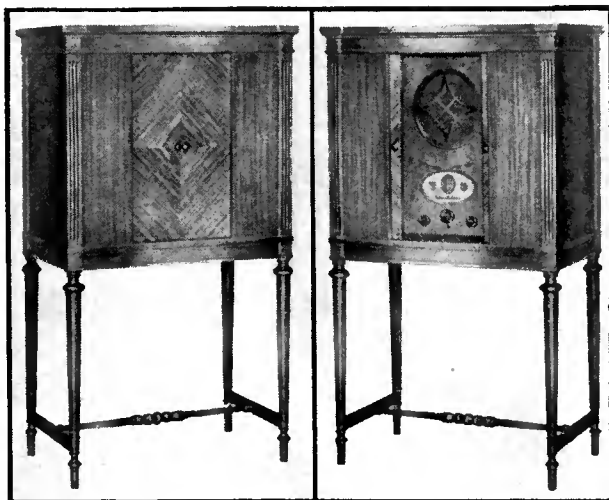

Two views of the new Silver Radio. This model in a sliding-door console cabinet lists for \$195.

DR. ALFRED N. GOLDSMITH is now vice-president and general engineer of the Radio Corporation of America. His former title was vice-president and chief broadcast engineer. As before his office remains at 411 Fifth Ave., New York City.

THE FRED G. SMITH COMPANY, 1049 Oakdale Ave., Chicago, has been appointed mid-west sales representatives of the General Amplifier Co., Cambridge, Mass. A. R. Wilson, formerly of General Radio, is president of General Amplifier which specializes in the design and manufacture of a complete line of power amplifiers.

JOSEPH GERSON is director of sales of the Buckingham Radio Corp., Chicago, one of the newest of the R.C.A. receiving set licensees.

ARCTURUS ANNOUNCES the appointment of John L. Stone as assistant to L. P. Naylor, sales manager. Other appointments include A. S. Van Bochove as western sales representative.

News of the Industry

THE JOY-KELSEY CORP., of Chicago, have reorganized and are now known as the Oxford Radio Corporation. The new company is locating in a new Chicago plant at 3200 West Carroll Ave., where dynamic loud speakers will be made exclusively. Frank Reichmann, in charge of sales and engineering, announces that it is planned to build 500,000 units during 1929.

THE TRANSFORMER CORPORATION OF AMERICA, headed by Ross D. Siragusa, president and general manager, has just removed to a new plant at 2301 South Keeler Ave., Chicago. The new equipment will give eight times the capacity of the former factory at 1428 Orleans St. At the new location 25,000 finished units a day can be produced.

THE WEBER DISTRIBUTING CORPORATION, formerly located at 90 West St., New York, is now located at 200 Hudson St., New York. The Weber Company distributed antenna wire, antenna kits, accessories, and replacement parts.

R. E. SMILEY, vice-president in charge of sales for Bremer-Tully, Chicago, announces that the purchase of the B.T. capital stock by Brnmswick in no way affects the sale or production of radio sets under the B-T trademark. Bremer-Tully will continue to operate under its own identity.

THE SHORT-WAVE transmitter of KOIL, owned by the Monamotor Oil Co., Council Bluffs, Ia., went into operation late in April. The call signal is W9XU, and the operating frequency 6060 kc. (49.5 meters). Operating schedule is from 6 A.M. to 10 A.M., 11 A.M. to 2 P.M., and 5 P.M. to midnight, daily. C. S. T. W9XU carries all KOIL programs including those of the Columbia system and local programs from the KOIL'S Council Bluffs and Omaha studios.

CLUB ALUMINUM ENTERS RADIO

THE CLUB ALUMINUM COMPANY and associates will manufacture an electric radio receiving set which will be sold direct to the home through salesmen and not dealers. It was announced by William A.

Burnette, president of the company. This phase of the company's business is termed the Radio Division and Douglas H. Cooke, of New York City, is general manager. All of the preliminary work has been perfected, it is said.

The Club Aluminum line will include three standard nine-tube models. In the manufacture of these sets the company has the use of all important radio and phonograph patents. The sets will retail at \$240 complete, with tubes, and installed in the home.

"The same selling policy of Club Aluminum which has brought its products into more than 2,000,000 homes in the United States will be adopted by the Radio Division," Mr. Cooke said. "Our men will take the radio direct to the home and give a demonstration." It is expected that 10,000 salesmen will be qualified to sell the sets in offices in every principle city in the United States by this fall.

**RADIO-VICTOR CORP. OF AMERICA FORMED**

THE RADIO-VICTOR CORPORATION OF AMERICA, incorporated under the laws of



*B. B. Minnium, radio engineer, Stewart Warner Corporation, Chicago, Ill.*

Delaware, will take over the sales activities of the R.C.A. and Victor. On the board of directors are representatives of General Electric, Westinghouse, and R.C.A. They include H. P. Davis, J. G. Harbord, J. L. Ray, A. W. Robertson, David Sarnoff, E. E. Schumaker, Gerard Swope, and Owen D. Young.

David Sarnoff is chairman of the board; J. L. Ray, president; I. E. Lambert vice-president and general counsel; A. E. Reoch, vice-president in charge of production, service, and traffic; H. C. Grubbs, vice-president Victor Talking Machine Division; Quinton Adams, vice-president Engineering Products Division; Meade Brunet, vice-president Radiotron Division; E. A. Nicholas, vice-president Radiola Division; E. C. Grimley, treasurer and comptroller; Francis S. Kane, secretary.

"The world-wide sales organizations of Victor and R.C.A.," said General Harbord, "will be brought together under one management. The personnel of both will be retained. The unified laboratory, factory, and sales facilities of the new company will make possible a more complete service to the trade and public, according to J. L. Ray, the new president,

Under the new arrangement the Van Courtlandt Park Laboratories of R.C.A. now house only the Research Division. This is headed by Julius Weinberger and his technical staff includes Messrs. Raymond Guy, Irving Wolff, T. A. Smith, Ringel, and Griswold. On April 15 the Technical and Test Divisions, headed by Arthur F. Van Dyck, removed to the Camden Radio-Victor plant. Located in Camden with Mr. Van Dyck are the following engineers: E. T. Dickey, F. H. Engel, E. J. Quinby, Anderson, Howard, and Bunting.

**CHANGES IN KELLOGG ORGANIZATION**

RECENT CHANGES in the Kellogg organization at Chicago include the appointment of W. J. Leighner as works manager, E. J. Brennan as Chicago District Sales manager, and Fred H. Timperlake, of Chicago, as sales representative in Michigan and Indiana.

Mr. Leighner for the past six years was works manager for Westinghouse plants at South Bend, Milwaukee, St. Louis, and Valdosta, Ga.

Howard F. Curran has been appointed manager of the Kansas City Branch, Edison Distributing Corporation. Mr. Curran was formerly radio department manager of H. L. Spencer Co., Iowa radio distributors.

**R.C.A. OPENS TRANSCONTINENTAL CIRCUIT**

THE FIRST STEP in an R.C.A. domestic radio system was taken recently, in the opening of a radio telegraph circuit between New York and San Francisco, according to James G. Harbord, president of R.C.A. In experimental operation, speeds as high as 250 and 300 words per minute have been obtained, using the "improved beam-projector" system. It is understood that about 20 kw. is employed in the high-frequency transmission. Interruptions due to static and fading have been minimized through the use of multiple receiving antenna systems. Message transmission is made on high-speed tape transmitters but it is understood that it is not yet possible to employ automatic recorders at the receiving end. Transmission is direct between New York and San Francisco and messages are accepted at the Boston and Washington offices of R.C.A. Communications, Inc., whence they are sent to New York by wire circuits. Rates are the same as those now applying on land wire circuits.

The Radio Dealer's Note Book  
**NO. 5. VACUUM TUBE MANUFACTURERS**  
*Free—Complete Information\**

ACCURATE summaries of useful information are constantly of value to those radio folk who deal with the public. This sheet, one of many on various subjects to follow, sets down collected information on vacuum tube manufacturers. The dealer or serviceman can remove this part of the page for his notebook or he can have it photostated.

Tubes are certainly the most important item, apart from radio receivers, that a dealer must handle. For this reason considerable thought must be given to the problem of how many makes of tubes he will stock and from what manufacturers he will purchase them. Even though a dealer may have decided these questions to his own satisfaction he should, nevertheless, make certain that he is thor-

oughly familiar with the products of all the tube manufacturers. Under such conditions the dealer will frequently find it possible to draw helpful comparisons between the tubes he is carrying and those being made by some other manufacturer. The list of manufacturers in this month's "Note Book" is quite complete, representing practically all of the prominent companies.

\*As a service to readers, the Editors have arranged that dealers may obtain complete information on the products of all the manufacturers listed in the table by writing to the Service Department of RADIO BROADCAST and asking for data on vacuum tube manufacturers. All requests must be written on a business letterhead or a card must be enclosed to identify the writer as a dealer or serviceman.

MANUFACTURER	TRADE NAME	REMARKS
Allan Mfg. and Electrical Corp.	Vogue	All types
American Bosch Magneto Corp.	Bosch	All types
Arcturus Radio Tube Co.	Arcturus	A. C. tubes and rectifiers
Armstrong Elec. & Mfg. Co.	Armor	All types
Bond Electric Corp.	Bond	All types
Cable Radio Tube Corp.	Speed	All types
CeCo Mfg. Co.	CeCo	All types
Champion Radio Mfg. Co.	Champion	All types
Consolidated Vacuum Tube Co.	Kovac	A. C. tubes and rectifiers
E. T. Cunningham, Inc.	Cunniogham	All types
Daven Radio Corp.	Daven	All types
DeForest Radio Co.	Audion	All types
Diamond Battery Company	Diamond	All types
Diamond Vacuum Products Co.	Diatron	All types
Duovac Radio Tube Corp.	Duovac	All types
Duval Radio Corp.	Duval	All types
Emerson Radio & Phonograph Co.	Elektron	All types
French Battery Company	Ray-O-Vac	All types
Gold Seal Electrical Co.	Gold Seal	All types
Grigsby-Grunow Company	Majestic	All types
Hygrade Lamp Co.	Hygrade	All types
Hytion Corp.	Hytion	All types
Hyvac Radio Tube Co.	Hyvac	All types
Kellogg Switchboard & Supply Co.	Kellogg	A. C. tubes only
Ken-Rad Corp.	Ken-Rad	All types
La Salle Radio Corporation	La Salle	All types
Marvin Radio Tube Corp.	Marvin	All types
Munder Electric Company	Vox	All types
National Carbon Co.	Eveready-Raytheon	All types
Neonlite Corp. of America	Neonlite	All types
Northern Mfg. Co.	Marathon	All types
Perryman Electric Co.	Perryman	All types
Radio Corp. of America	Radiotron	All types
Baytheon Mfg. Co.	Eveready-Raytheon	All types
Schicklerling Products Corp.		All types
Sonatron Tube Co.	Sonatron	All types
Sunlight Lamp Co.	Crusader	All types
Sylvania Products Co.	Sylvania	All types
Televocal Corp.	Televocal	All types
The Quinn Radio Tube Co.	Quinn	All types
Triad Mfg. Co.	Triad	All types
Tung Sol Lamp Co.	Tung-Sol	A. C. tubes and rectifiers
Universal Electric Lamp Co.	Buck	All types
Van Horne Tube Co.	Van Horne	All types
Zetka Labs., Inc.	Zetka	A. C. power tubes and rectifiers

THE ALLIED BROADCASTING COMPANIES, INC. are now located at 1780 Broadway, New York City. Allied Broadcasting represents the following west-coast stations: KJR, Seattle; KEX, Portland; KGA, Spokane; KYA, San Francisco; KMTR, Los Angeles; KDYL, Salt Lake City; and ELZ, Denver. The New York Office handles all matters relating to broadcasting on this network from points east of Chicago.

RADIO SET FOR AUTOMOBILES

THE AUTOMOBILE RADIO CORPORATION of New York recently showed a receiver called the "Transitone" for installation on motor cars. The controls of the set are located in the dashboard of the car by re-locating the instruments there; the antenna is installed in the roof, or, if the car is of the open type, the screen antenna folds down with the top with satisfactory results in either position. A standard tuned r.f. circuit is used and a special filter system to reduce ignition noise is a part of the installation. Offices of the company are at 37-7 Queens Boulevard, Long Island City, New York. Ralph Heina is chief engineer.

ZENITH ENTERS LOW-PRICE FIELD

MODEL 42 is announced by Zenith, of Chicago, to sell at \$175. It uses eight a.c. tubes including rectifier. Screen-grid tubes are employed as well as "automatic" tuning. Unusual sensitivity is obtained, according to the announcement, through the use of a separate control which serves as a combination switch and volume control. Additional selectivity is attained through the use of another control on the right. A patented switch and connection is also provided for a phonograph pick-up unit. The automatic tuning unit is concealed at the upper right of the cabinet, which is a lowboy console. Zenith states that its recent acquisition of a new factory in which all their cabinets are produced enables decreases in list prices. The company now makes all its parts as well as cabinets.

NEW KELLOGG RECEIVERS

THREE NEW SETS are announced by Kellogg, of Chicago, Nos. 523, 524, and 525. Each employs screen-grid a.c. tubes and large power-handling tubes in the last stage. Model 525 is a combination

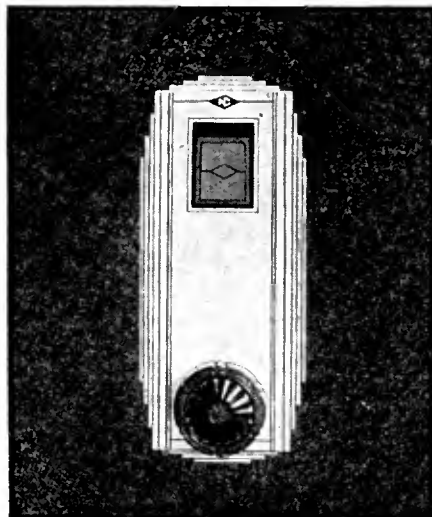

The new National "Rainbow" dial is of modern design and construction. As the knob is turned the scale reading is projected in color on the ground-glass screen.



The Transformer Corporation of America has removed to the new plant pictured above. Their new equipment will have eight times the capacity of the former factory.

radio-phonograph set. The other two are arranged to permit the use of a phonograph pick-up unit. Each set has three screen-grid tubes in the r.f. system feeding a "power" detector with high plate and grid voltages. The detector output in model 523 feeds a push-pull 245 audio channel, while two 250 tubes in push pull are used in the other models. Each set is equipped with a manual and automatic volume control. Model 523 employs the following tubes: three screen-grid a.c. tubes, three 227-type a.c. tubes, two 245-type power tubes, and one 280-type rectifier. Model 524 and the radio-phonograph, model 525, use the following: three 224's, three 227's, two 250's, and two 281 rectifiers.

CONTINENTAL RADIO OFFICERS

OFFICERS AND DIRECTORS of the Continental Radio Corporation, Fort Wayne, Ind., are Charles M. Neizer, chairman of the board; S. Paul Mozeman, vice-president; John A. Thieme, secretary-treasurer; other board members are, Henry J. Miller, W. H. Noll, W. J. Vesey, Max B. Fisher, Carl D. Boyd, W. C. Rastetter, and Joseph Lush (also treasurer, Hammarlund Mfg. Co.). Carl D. Boyd is president of the company, and Henry S. Schryver is chief engineer.

NEW TELEVISION SCHEDULE

IN ORDER to allow a greater period for study of television reception at various locations, especially during the evening, the daily transmission schedule of the Radio Corporation's experimental television station, w2xbs, has been extended to include the hours of 9-11 P.M. This change took effect May 6th. Beginning April 30th, w2xbs has been operating on Eastern Daylight Saving Time.

Since early in March, when the operating schedule was announced, w2xbs has been transmitting daily from 7-9 P.M. on a frequency of from 2000-2100 kilocycles. Transmitted pictures consist of sixty horizontal lines, each divided into seventy-two elements laterally. Twenty pictures are scanned per second. The new daily schedule will permit experimenters to observe signs, photographs, and views of persons between the hours of 7-11 P.M.

NEW FINANCE PLAN

UNDER THE terms of an arrangement just completed between the Kellogg Switchboard and Supply Company of Chicago, and the General Contract Purchase Corporation of New York, Kellogg dealers may now avail themselves of a

convenient and economical method of handling their customer's time payment paper.

A feature of the plan is a copyrighted sales chart furnished to the dealer which eliminates any necessity on the part of the dealer for figuring terms or rates.

With the payment chart the dealer merely asks the customer how much he or she can afford to pay each month on the due balance. The sales chart then gives the exact amount of the contract, the exact amount of the payments, and the number of months the contract runs. Another most desirable feature of the plan is that the customer, seeing the printed figures, does not try to haggle or bargain. He accepts them as they are.

ERLA BUYS CABINET FACTORY

THE CHICAGO PLANT of the Cable Piano Company was bought by the Electrical Research Laboratories. Cabinets, receivers, electromagnetic pick-up units, and dynamic loud speakers will be manufactured. Equipment for manufacturing 1500 cabinets daily was taken over as part of the purchase, and contemplated additions to the equipment are expected to increase cabinet capacity to a maximum of 2500 per day.

Manufacturing operations now conducted at the Erla plant at 2500 Cottage Grove Ave., and at the Greene-Brown plant at 5100 Ravenswood Ave., will be transferred to the Cable plant as rapidly as possible.

THE CHICAGO OFFICE of the DeJura-Amsco Corporation, at 77 West Washington Street, has been removed to larger quarters in the Wrigley Building, Chicago. The change was made May 1st. Mr. William E. Burgoyne is in charge.

SPARTON DEVELOPMENTS

CONTINUING ITS POLICY of manufacturing of every part that goes into Sparton sets the Sparks-Withington Company of Jackson, Michigan, are equipping a new plant for the making of light metal punchings. Machinery is being installed which will be used in the making of a great number of parts for Sparton sets. The new plant will provide space for several hundred additional employees. During the peak of the 1928 season more than 4000 persons were engaged in the making of Sparton sets, and this will be increased greatly during the coming year. The Sparton organization has grown from approximately 500 individuals to more than 4000 within the short space of four years.



# LOUD SPEAKER RESPONSE MEASUREMENTS

By P. H. TARTAK

*Chief Engineer, Sleeper Radio and Manufacturing Co.*

WITH THE ever increasing demand of the public for faithful reproduction and true tonal values from loud speakers it has become necessary for various manufacturers to develop equipment of such a nature that the fidelity of loud speakers may be indicated by some visible means and the results examined at leisure. This article deals with a method for measuring the characteristics of a loud speaker on a comparative basis. It also includes a discussion for making tests on amplifiers and radio sets.

The tests performed are applicable only to a laboratory and were made in a specially constructed sound-proof room. A loud speaker under such conditions would not give the same response to the ear that it would if it were operated in the average home because of the acoustical properties of the room. However, the results are indicative of the performance of one loud speaker in comparison to another subjected to the same test and under the same conditions.

To study the behavior of the loud speaker under test with variation in frequency output, a responsograph and its associated equipment were used. This apparatus consisted of a beat-frequency oscillator having an external variable condenser the shaft of which was coupled to a drum on the responsograph. The output of the oscillator was put through an a.f. amplifier and then to the loud speaker on test in the sound-proof room. A two-button microphone was placed in front of the loud speaker and a shielded cable led from this room to the modulation control box and then to an amplifier, whose output fed into a specially designed vacuum-tube voltmeter. The microammeter, which is a part of the vacuum-tube voltmeter, was mounted inside the responsograph.

The responsograph itself is shown in Fig. 5 and consists of a variable condenser whose rotor is coupled to a paper roller. The frequency of the oscillator is altered by rotating the condenser, which moves the paper strip upon which the graph is made. At the same time the variations of the needle on the microammeter are followed by a lever which is connected to a stylus. The stylus is constructed so that its motion is linear, even though the motion of the needle is circular.

An audio-frequency oscillator of the heat-frequency type was found to work best for making the curves because of the ease of varying the frequency from 50 to 5000 cycles. The oscillator produced a very good sine wave as indicated by an oscillograph and its output was very steady over the entire range. The detector output of the oscillator was arranged so that it could be switched to any type of a.f. amplifier, since different types of response curves of loud speakers could be obtained by using different amplifiers and tubes.

### *The Sound-Proof Room*

THE SOUND-PROOF room is of specially constructed sound-absorbing material and its walls are eight inches thick. By placing the microphone at various dis-

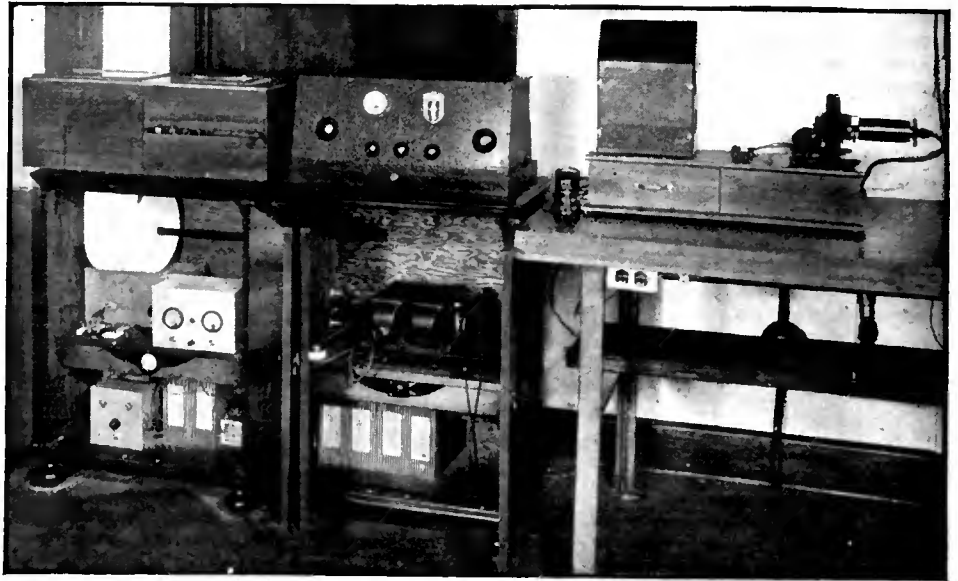

*Fig. 1—Complete view of the loud speaker measuring apparatus described in this article.*

tances and angles from the loud speaker it was determined that standing waves due to reflection were negligible. The picture in Fig. 2 shows the interior of the sound-proof room with a speaker microphone in test position. It was found by experiment that the best results were obtained when the microphone was placed one foot away from and in line with the center of the loud speaker because the waves were then transmitted directly to the microphone.

A two-button microphone was used in conjunction with a resistance-coupled amplifier having a straight-line-frequency response. As can be seen from Fig. 3, the amplifier is arranged so that the output

may be attenuated by means of varying the resistance in the grid circuit of the last tube.

The vacuum-tube voltmeter is of the plate-rectification type and uses the voltage-bucking method of keeping the plate current out of the microammeter. In order to get the complete curve on the paper without changing the scale or attenuating the signal during a single test the vacuum-tube voltmeter was designed so that its voltage variation was not linear. This was accomplished by using the proper shunt across the meter and a resistance in series with it. For convenience in making the test and also for increasing the accuracy of the vacuum-tube voltmeter, a reading of ten microamperes was taken for the zero setting. The d.c. voltmeters are arranged in the circuit so that the correct filament, grid, and plate voltages may be obtained readily, thus maintaining the calibration of the voltmeter.

Figs. 1 and 4 indicate apparatus layout as well as their position with reference to the responsograph.

In order to keep the results consistent from day to day, middle "C" or 256 cycles was chosen as a reference point and the output of the apparatus was adjusted at this frequency. At the beginning and end of each test the output of the oscillator-amplifier combination was thrown to a calibrated vacuum-tube voltmeter used as a volume indicator and the value checked at 256 cycles. By keeping this value constant for all readings and also noting the attenuation on the microphone amplifier all the curves were comparable.

In all loud-speaker response curves, the sound intensity in dB was plotted against frequency. The equipment was adjusted so that the highest peak obtained reached the 100 mark on the microammeter scale. This voltage, E, was taken and the height of the various reference points were calculated in dB on this basis. From the mathematical



*Fig. 2—Interior view of the sound-proof room in which loud speaker measurements are made.*

formula  $dB=20 \log E$ , and from the calibration of the vacuum-tube voltmeter, E was obtained for various points. Thus it was possible to measure just how many dB one peak was above another.

Curve A in Fig. 6 shows the response curve for an Airchrome loud speaker; B is the curve of an air-column loud speaker; C is that of a cone loud speaker; D is that of a dynamic loud speaker, and E is that of the same dynamic with the condenser across the loud speaker input. The curves indicate the resonant peaks caused by the component parts of the loud speakers and units. By using filters consisting of condensers and chokes, various peaks can be removed without affecting the response at any other point. The first resonant peak of fair size indicates the fundamental response of the diaphragm.

Value of Curves

INASMUCH AS the microphone was not calibrated with the equipment used, the tests, as previously explained, have been made only on a comparative basis; that is, the performance of a loud speaker and the response in one loud speaker can be compared to another only when the tests are made in the same laboratory. However, by using a condenser microphone and a thermophone, the responsograph can be calibrated easily on an absolute basis, in which case the curves obtained in one laboratory would be comparable with those obtained in another one.

Unless a pure sine wave is impressed at all times, the shape of the curves for any loud speaker would not be the same from time to time and the tests would mean nothing.

All of these tests were made using a sinusoidal input and do not indicate the performance of the loud speaker when music or speech is impressed. This accounts for the fact that, although a loud speaker very often gives a good response throughout the entire range of frequency, it does not perform well on mixed frequencies. This is due to the fact that the lower frequencies carry most of the speech energy while the articulation and intelligibility depend upon the higher frequencies.

In studying the behavior of loud speakers it was observed that changing the shape of the diaphragm or its mass affected its response. It was also observed that when a loud speaker had a condenser across its input the high frequencies were cut off. This gave the low frequency or bass notes a predominance and speech then became difficult to understand because the articulation decreased when the high notes were cut off.

Using the responsograph, it was also possible to study the effect of baffling loud speakers, the response varying with the size of the baffle. It was also possible by means of the responsograph to determine the cabinet resonance of any compartment in which the loud speaker was placed. Another interesting experiment consisted of testing the efficiency of

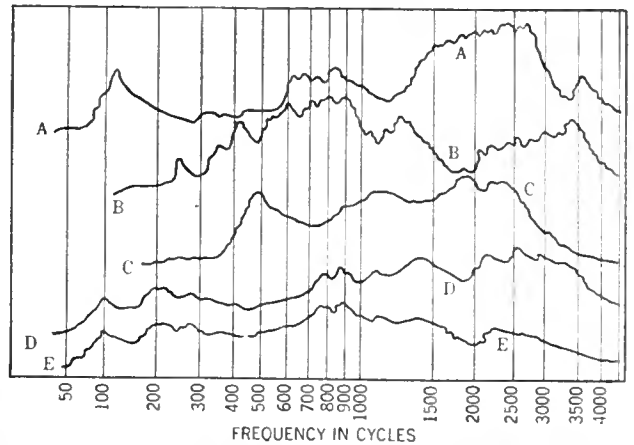

Fig. 6—Sample response curves made with five different types of loud speakers. Note: These curves are not intended to indicate the level at which the speakers are operating but only the relative response at various frequencies.

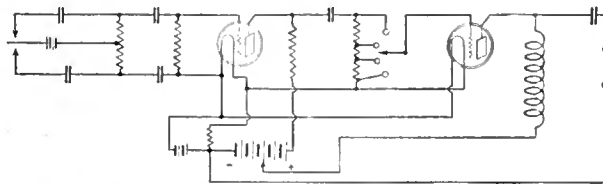

Fig. 3—Schematic diagram of the a.f. amplifier used in making loud speaker response measurements.

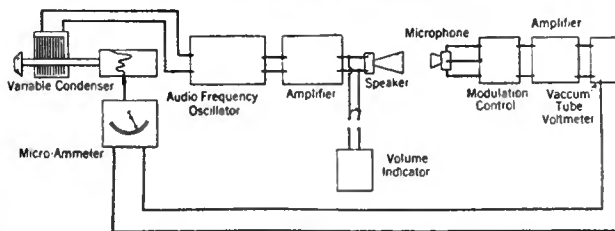

Fig. 4—Schematic diagram showing the set-up of apparatus when making loud speaker comparisons.

various band-pass filters as well as determining how sharp the cut-off's were.

Another use to which the responsograph could be put is to measure the overall characteristics of a radio set and loud speaker combination. For this purpose an r.f. oscillator modulated by means of a beat-frequency oscillator would be used. With this apparatus it would be possible to observe just how cutting off sidebands affects the a.f. system. It would also provide a means of perfecting the radio set so that there is nearly constant frequency response throughout the entire range.

The author wishes to acknowledge the use of apparatus and the assistance which has been rendered by Professor Andres and his staff of engineers at the Temple Laboratory.

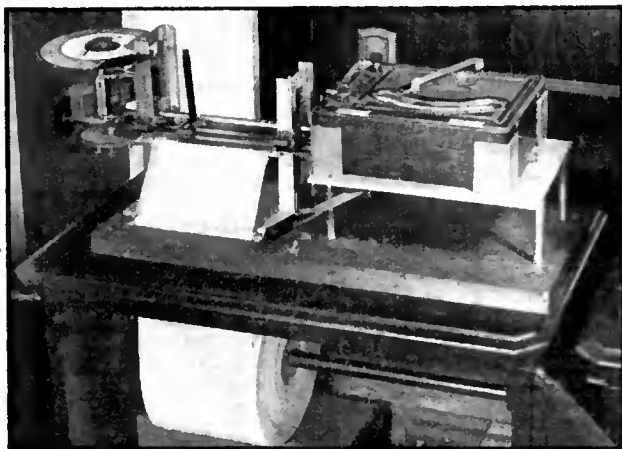

Fig. 5—View of a responsograph of the type used for making comparative loud speaker measurements.

BOOK REVIEWS

TELEPHONE AND POWER TRANSMISSION, by R. Bradfield and W. J. John. Published by John Wiley & Sons, Inc., New York City, 234 pages. Price: \$5.75.

This new book will take its place in the telephone library along with other standard texts on the theory underlying the transmission of intelligence along wires. It was written by R. Bradfield, late of the engineering department of the British General Post Office, and W. J. John, lecturer in electrical engineering at East London College.

This book is not like that of K. S. Johnson's *Transmission Circuits*, a practical book, but is one dealing with the mathematical theory of the propagation of electric waves on wires. It furnishes its own mathematics but to prevent throwing a scare into any potential reader, let us hasten to set down the aim of the authors, "to write for that vast majority of students and practical engineers who are engineers first and mathematicians only in so far as their profession demands."

The authors realize that hyperbolic functions look more formidable than they really are, and that a telephone engineer has little need for the mathematical concepts on which hyperbolics are based. An engineer wants to know how to solve problems by their use—and to serve that end, examples and problems are included in the text.

There are chapters on general theory of transmission, the application of theory to actual telephone transmission, measurements of line constants, transmission of power on wires, effect of transformers on voltage drop in transmission circuit, traveling waves in transmission lines, etc.

More than half of the book is taken up with the transmission of power on wires, and for anyone contemplating the transmission of radio programs on power wires, this part of the book is useful.

There are a number of tables in the book on such subjects as sizes and resistances of standard-gauge wires, attenuation of various types of lines, mathematical tables of hyperbolic functions, etc. It is interesting to note that the decibel (dB) or the transmission unit does not seem to be mentioned in the book and that losses and attenuation is still spoken of with regard to the mile of standard cable. —K. H.



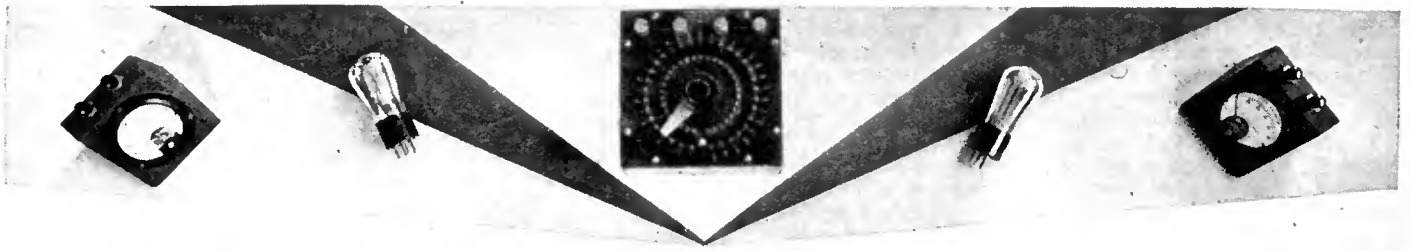

# STRAYS from THE LABORATORY

## Data on Foreign-Made Pentode Tubes

THE CURVES IN Fig. 1 and Fig. 2 are published through the courtesy of M. E. Bond, engineering department, American Bosch Magneto Company. They show the power output from a Mullard Pentode, and the manner in which it varies with various load resistances. It is interesting to note that with an input of 5 volts on the grid, a power output of 800 milliwatts can be obtained. In the Laboratory it was possible to get this same power from the Philips (Holland) Pentode with a grid voltage of 16, and so the Mullard valve is more sensitive.

Experiments in the Laboratory with Ediswan Pentodes indicate that such a tube with 150 volts on the plate and drawing about 12 milliamperes will deliver power equal to that from a push-pull 171 amplifier with about one third the input voltage.

Listening tests, comparing the Ediswan Pentode working into standard loud speakers through an Ingranic output transformer designed to couple these high-resistance tubes to low-resistance loud speakers, indicate that there is still a lack of low-frequency response compared to the reproduction from the 171 push-pull amplifier using an Amertran transformer. This lack of low frequencies, however, is not as bad as may be noted from some of the newly designed loud speakers sold in this country, and touted as being the last word in "perfect reproduction."

## Symbols Used in Technical Radio Writing

IN RADIO LANGUAGE there are many symbols, short-hand expressions, that make it rather picturesque and rather unintelligible for the layman. Some of these symbols have international acceptance, some are used only in this country, and some have not been agreed upon generally even in this country.

For example the Greek letter "omega" ( $\omega$ ) is sometimes used to indicate resistance in ohms, and sometimes megohms. Similarly, the large Greek letter "omega" ( $\Omega$ ) is used indiscriminately for ohms and millions of ohms.

The Greek letter "mu" ( $\mu$ ) is used generally in this country for the amplification factor of a vacuum tube. It is also an abbreviation for "millionths"; thus, microhenry is abbreviated to  $\mu$ h.

The small "omega" ( $\omega$ ) is used for the expression  $2\pi f$  or  $6.28 \times f$  where  $f$  is the frequency in cycles. It enters into many electrical calculations. Thus, the reactance of an inductance is  $\omega L$  or  $6.28 \times L \times f$ . Strictly speaking,  $\omega$  is an abbreviation or symbol for the "angular velocity of the vector representing a sine wave of current or voltage, and is expressed in radians." A radian is a measure of the arc through

which the end of the vector travels, 6.28 radians constituting an entire circle of 360 degrees.

The Greek letter "lambda" ( $\lambda$ ) is used for the wavelength in meters. Thus  $\lambda = 300$  would be read "wavelength equals 300 meters."

The small or capital letter "r" and "R" is used almost universally for resistance.

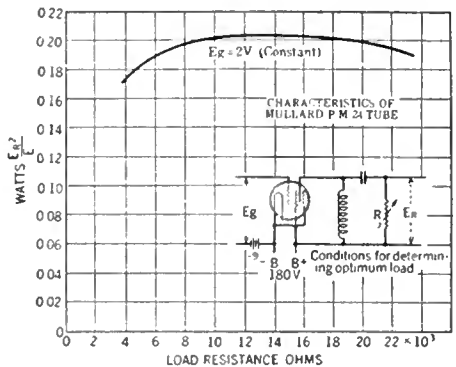

Fig. 1

Thus,  $R_p$  indicates the plate resistance of a tube. The letter  $p$  is called a subscript and states that "R" in this case is a particular resistance, that connected with a tube.

In a similar manner, subscripts are used on the letters "E" and "I", denoting voltages and currents to form  $E_p$ ,  $E_g$ ,  $E_r$  for the plate, grid, and filament voltage of a tube, and  $I_p$ ,  $I_g$ , and  $I_r$  to indicate the plate, grid, and filament currents. Generally speaking, large letters denote d.c. values, small letters indicate a.c. values, but here the usage is not universal and some authors use one convention, some another. Thus,  $I_p$  may refer to the steady B-battery current in the plate circuit of a tube. This flows whether or not there is any a.c. grid voltage,  $e_g$ . When there is

an a.c. grid voltage there is an a.c. plate current,  $i_p$ , as well as the d.c. plate current.

The letters "db" are used as an abbreviation for the "decibel," a unit of transmission loss or gain. It has the same value as the  $\mu$  which it replaces in technical language.

The letter "G" is a symbol for conductance. A conductance is an expression telling how well a certain circuit conducts currents, just as resistance tells how much it impedes the progress of a current. Conductances are measured in mhos (ohm spelled backwards). Thus, the mutual conductance of a tube is its  $G_m$  and is usually expressed as micromhos. In England this expression becomes "S," the steepness of the grid voltage-plate current curve.

The Greek letter "tau" ( $\tau$ ) is sometimes used for the coefficient of coupling between two coils; sometimes the letter "K" is used for this same expression.

## Fluorescence in Radio Vacuum Tubes

WE NOW HAVE the last word on the strange flickering of light within a vacuum tube when signals are put on its grid. We had laid it to fluorescence, and, following the dictionary, stated that this fluorescence was due to organic material within the tube. This theory was exploded by a reader who wonders how any organic material could survive the heat which the tube undergoes in the manufacturing process. He is correct; no organic matter could. And here is the correct explanation, coming from the engineering department of the General Electric Research Laboratory.

"Fluorescence under electron bombardment is a property possessed by a number of different chemical salts. For X-ray work zinc sulphide is one of the ingredients most commonly used. It is also well known that certain salts of barium and calcium fluoresce when bombarded by electrons under certain conditions.

"It, therefore, seems very probable that the outside of the anode of the tube accumulates a small amount of some salt which shows fluorescence under electron bombardment.

"There may be several sources for such material; notably, from the active filament coating or the getter used. The gas free specially cleaned anode surface is particularly sensitive to receiving such an active material. During operation of the tube there are many stray electrons that have escaped through the end of the grid and plate and these strike the outside of the plate. Variations in grid voltage at an audio rate change the path of the electrons and, therefore, cause different portions of the plate to fluoresce.

"Fluorescence is not associated with organic material, as is well proven by the ordinary X-ray fluorescent screen. Phosphorescence, however, is usually associated with an organic material."

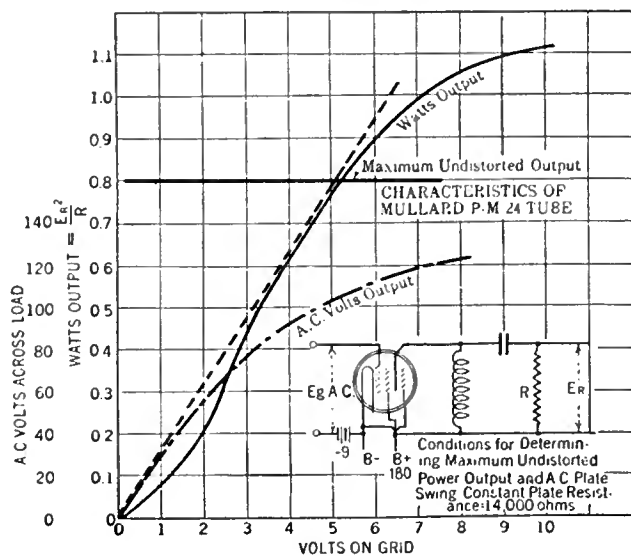

Fig. 2

# ENGINEERING BEHIND A CROSELY SET

By KENNETH W. JARVIS



Kenneth W. Jarvis

EVERY SEASON has brought forth upon the market new radio receivers; new in appearance, new in operations, and new in claims as to their great superiority over all previous models. Just what provokes this customary offering on the altar of public service? Technically, it is a result of new inventions

or from more intensive engineering development. From the merchandise angle, the public demand for something new and different is an impelling motive. It is the purpose of this article to show how such a recent set (the Crosley Jewelbox) was developed and how its claims to superiority are justified.

The "average" radio receiver of last season comprised an untuned radio-frequency amplifier and two or more tuned stages of radio-frequency amplification. This was followed by a grid-leak-condenser type detector using a heater tube, such as the 227. The first audio stage, as did the radio stages, used a low-voltage filament tube such as the 226. The output system employed one or two low-impedance tubes such as the 171A. The set was transformer coupled throughout, good design insuring a satisfactory fidelity. The volume control was a variable input system to the untuned r.f. stage.

## The First Improvement

WITH THIS as a starting point, changes can be suggested and tried out. The first proposal is to change the input system. The advantages of the untuned input system are very real or so many manufacturers would not have used it. Its greatest advantage is in producing a unicontrol set, as the antenna capacity cannot affect any of the tuning units. It is economical and conservative of space and material. A properly designed choke coil can be used to provide a greater amplification on the lower radio frequencies and thereby flatten out the usually sloping sensitivity curve. It provides a convenient place to operate a volume control.

However, in comparison with a tuned input system, the untuned amplifier shows several gross faults. It is relatively insensitive. If the average amplification over the entire broadcast band is greater than one, the designer may consider himself fortunate. The untuned system does not contribute in the least to the selectivity of the receiver, a factor which is requiring major consideration in these days of congested broadcast traffic. Due to the fact that no vacuum-tube amplifier is absolutely linear in characteristics, this untuned stage may produce peculiar effects. The second harmonic of strong local stations may be generated in this tube and

then the station may be received at two places on the dial. Obviously, this can occur only with stations operating between 550 and 750 kilocycles. (The second harmonic of 750 kc. is 1500 kc., the limit of the tuning range of the receiver). Due to this same non-linear characteristic, and the lack of selectivity, a strong local station may modulate a weak distant station, and therefore be heard whenever these weak stations are tuned-in.

There is certainly room for improvement here. The tuned stage has major advan-

*The respective merits of untuned and tuned antenna systems, "power" detection and conventional detection with the two-stage audio amplifiers, as well as the engineering data behind the Crosley Jewelbox receiver will be found in this article by Mr. Jarvis, formerly of the Crosley Radio Corporation and now Chief Engineer of the Sterling Mfg. Co., of Cleveland, Ohio.*

THE EDITOR.

tages in the increased amplification and selectivity. However, the cost is greater and it adds an extra control to the receiver. Measurement and experiment have shown that the proper utilization of these advantages far outweighs the disadvantages. A comparative idea may be obtained from a study of Fig. 1. The dashed line shown is an amplification curve of a good choke-coupled untuned radio-frequency amplifier. In this, and the other curves in this figure, the amplification is measured from the input voltage in the dummy antenna system to the grid of the first tube.

## Antenna Input Design

IN THE design finally adopted for the antenna system, a coil with three taps at 3, 15, and 36 turns was used. These are numbered (3), (2), and (1), respectively, in Fig.

1. Tap No. 3 is used with extremely large antennas, or when exceptional selectivity is required. However, even with this small coupling, the average amplification is much better than the untuned stage. Tap No. 2 is used for the average antenna, and in the hands of the average owner is connected once and is never changed. Tap No. 1 is for an extremely small or indoor antenna. On a normal antenna, this tap will give a greater sensitivity to low radio frequencies than Tap No. 2. The relative efficiency of these curves compared with the untuned stage needs no comment. In addition to the great increase in sensitivity, a proportional gain in selectivity is made.

After determining that the tuned input was desirable, the mechanical problem had to be solved. Due to the antenna capacity, this stage could not be made to rack exactly with the other stages. In the hand of an unskilled operator, it is extremely desirable that the input tuned stage always be tuned approximately, as the great increase in selectivity in this stage results in greatly decreased sensitivity unless the tuning condenser is maintained approximately in resonance. This makes some form of a four-gang condenser (there are four tuned circuits in this receiver) necessary, with the required adjustment on the first tuned circuit to compensate antenna variations. Various combinations were tried to accomplish this compensation, and the simple means of rocking the "stator" was finally adopted as being the best. This rocking movement is obtained by a worm wheel drive on a molded gear segment mounted on the stator of the condenser. The great reduction in gear ratio makes the tuning of this selective circuit very easy. Due to the way the condenser tuned circuits follow each other, only a slight adjustment of this control is necessary to bring the receiver to the peak of its sensitivity and selectivity.

Another change which may be noted here is in the use of heater-type tubes throughout. The a.c. hum voltage is lowered greatly when 227-type tubes are substituted for the 226 type. This is due to decreased modulation of the radio-frequency amplifiers by the filament power-supply voltage, and to the lowered hum voltage in the first a.f. stage. The volume control is arranged by varying the grid bias on the radio-frequency amplifiers. This cannot be done on the 226-type tubes due to the resulting hum modulation. In general, a volume control operates more satisfactorily when the sensitivity of the radio-frequency amplifiers is reduced, due to the reduction of the hiss produced in the tubes themselves. Thus, the use of the heater tubes allows this better type of volume control to be used.

## New Detector Circuit

BY FAR the biggest change in the new receiver lies in the use of the bias-type detector. As very little data has been pub-

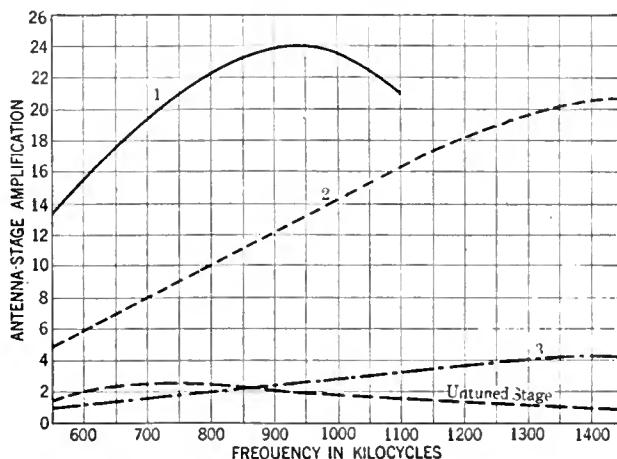
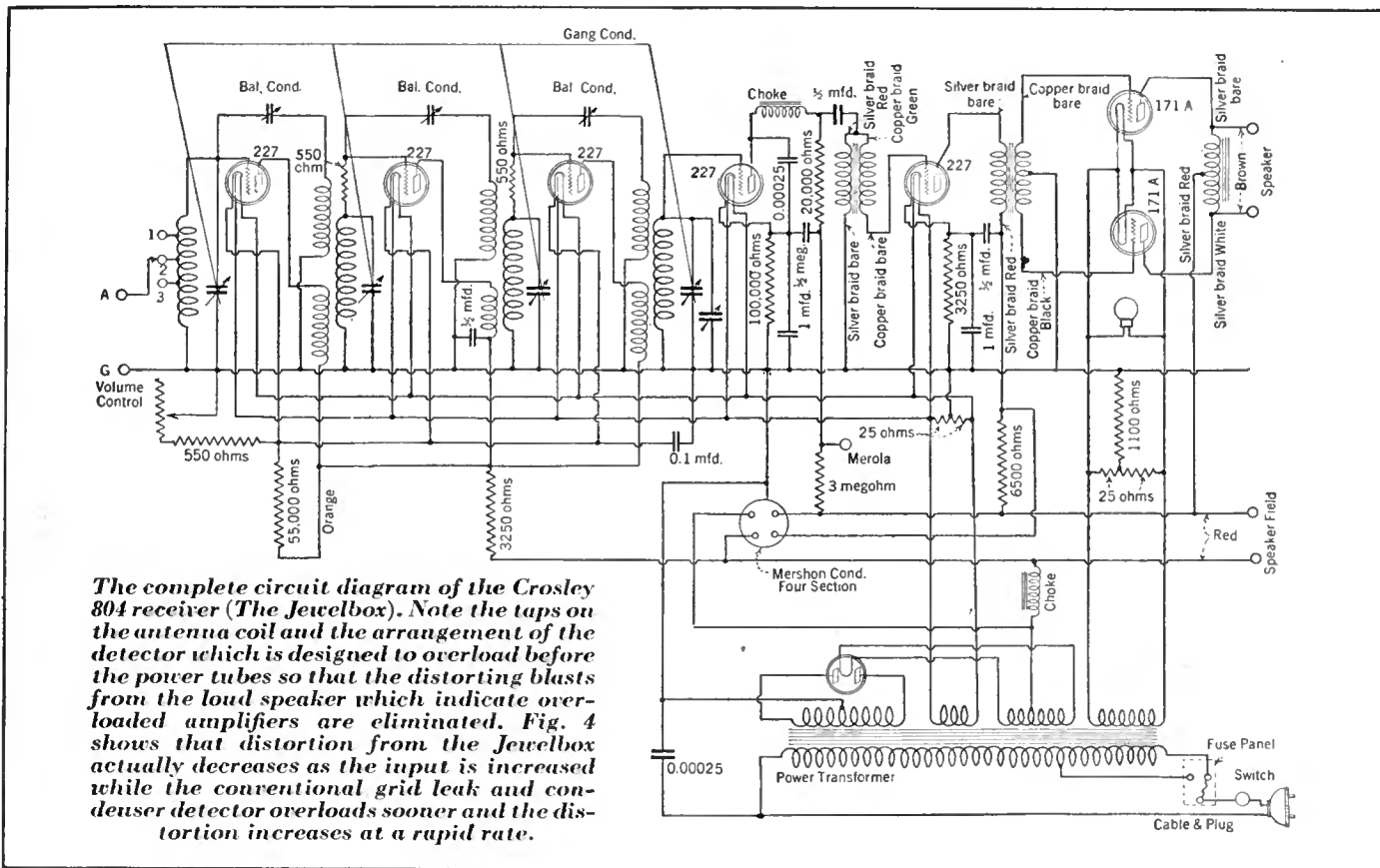

Fig. 1—An idea of the increased amplification and selectivity obtained with a tuned input stage may be gained from a study of this graph.





The complete circuit diagram of the Crosley 804 receiver (The Jewelbox). Note the taps on the antenna coil and the arrangement of the detector which is designed to overload before the power tubes so that the distorting blasts from the loud speaker which indicate overloaded amplifiers are eliminated. Fig. 4 shows that distortion from the Jewelbox actually decreases as the input is increased while the conventional grid leak and condenser detector overloads sooner and the distortion increases at a rapid rate.

corresponding to about 1-watt output (171's in push-pull with 4000-ohm load), the power distortion is only 1 per cent. As the radio input is further increased, the output voltage increased to about 82 volts (output 1.7 watts) with a distortion of 9 per cent. If the radio input voltage be further increased, the audio output voltage will decrease as shown by the reversing curve. The percentage of harmonics increases slightly and then decreases as the radio input is continuously increased. This is a new idea in receiver design and one which deserves further comment.

The Output Circuit

THE OUTPUT system of this set consists of two 171A-type tubes in push pull. Singly, these tubes are capable of delivering about 0.7 of a watt. In push pull they will deliver slightly more than twice this value, about 1.5 watts. If the input voltage to such a push pull stage is increased to give a greater power output, the distortion will be enormously increased. In fact, it will sound terrible!

But if some means were provided to prevent a great overload of these out-

put tubes, it is apparent that even in the hands of an inexperienced operator, it would be impossible to overload the output system. The receiver can never be made to deliver a signal of poor quality!

This novel effect is obtained by proper adjustment of the detector voltage characteristics, so that as the detector overloads it not only fails to contribute greatly to the distortion, but actually serves to reduce the distortion if the input is sufficiently great.

choice on a basis of distortion. An output of at least one watt is possible without perceptible distortion. The limit beyond this point is largely a matter of customer discrimination. It can, of course, be pushed until the distortion is apparent to every one, including the neighbors. An automatic overload control such as is shown in curve A is a real contribution toward the improvement of modern radio reception.

Sensitivity of Receiver

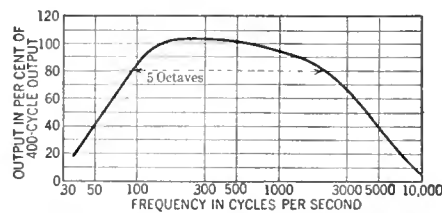

Fig. 6—Overall fidelity curve with the r.f. stages tuned to 1000 kc.

THE CURVES shown in Fig. 5 are the usual sensitivity curves plotted in microvolts per meter. The sensitivity on tap (3) was sacrificed to some extent to provide for an extreme selectivity. As shown previously, in the tuned antenna stage discussion, the combination of the characteristics of the three antenna taps makes the receiver adaptable to almost any receiving condition. A comparison of these curves with those shown in a previous article in the January, 1929, RADIO BROADCAST will show what an enormous improvement has been made in this receiver.

In Fig. 6 is shown a fidelity curve taken at 10 per cent. distortion is shown as the "Minimum Perceptible Distortion." This is perhaps a pessimistic viewpoint as many individuals in test have permitted a power distortion as high as 25 or 30 per cent. before noticing it. To an untrained ear, this is perhaps excusable. At low percentages, this distortion is apparent only as a change of timbre, or tone quality, and has no characteristics of discord or poor quality. As indicated, this "Minimum Perceptible Distortion" means that point at which a change in timbre becomes apparent. If further comment were needed it would only be necessary to show the great distortion in some receivers whose owners claim them to have the finest quality on earth!

With this idea of what distortion means, the curve n of Fig. 4 may not be judged too harshly. Certainly at low (and probably the normal room volume) there is no

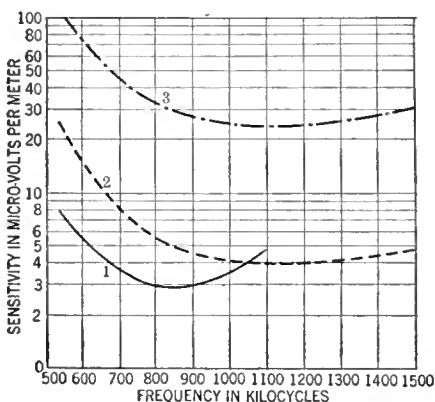

Fig. 5—Sensitivity curves of the Crosley receiver.

choice on a basis of distortion. An output of at least one watt is possible without perceptible distortion. The limit beyond this point is largely a matter of customer discrimination. It can, of course, be pushed until the distortion is apparent to every one, including the neighbors. An automatic overload control such as is shown in curve A is a real contribution toward the improvement of modern radio reception.

In considering the development of this receiver and the results obtained, the Crosley engineers feel that they have not merely brought forth another receiver, but one deserving in every particular of the sobriquet of "new."



# An Invaluable Device for Radio Servicemen

## A SIMPLE LINE-UP OSCILLATOR

By **GLENN H. BROWNING**

Consulting Engineer

**T**HE AVERAGE serviceman is equipped to take care of the ordinary troubles which are encountered in receivers. However, many times the set simply lacks signal strength on semi-distant stations and a careful check on voltages and tubes shows that as far as they are concerned the set is ok. Usually, in this case, the tuning circuits are not lined up properly and as a consequence signal strength is lost.

In some single-control receivers there are small compensating condensers which may be adjusted; in other cases the only way to line up the gang of tuning units is to bend slightly the rotor plates of the tuning condensers. In either case it is very difficult to make this adjustment unless there is a station transmitting which is just audible in the loud speaker, and even then, when the set has three or four tuned circuits, it is somewhat of a question as to which of these are off resonance. In fact, this question of alignment in single-control receivers is becoming a problem.

The set manufacturer, of course, does his best to see that the receivers are inspected carefully before they leave the factory, but in mass production there are always slips.

For a number of months the writer has used an oscillator with a grid meter for determining the resonance point of any tuned circuit. This has been found so convenient and accurate that he wishes to pass the idea along. Fig. 1 shows the circuit used. It will be noted that a standard type of oscillator is used and that the design is such that it may be connected to any a.c. or d.c. electric light socket. R is a 440-ohm resistor which will carry a quarter of an ampere for the filament supply of the 201A-type tube. The 110-volt supply is not connected to the plate of the tube as more accurate readings may be obtained when the oscillatory current is low, which will be the case if only about 22 volts is used for the plate supply.  $C_1$  is a variable air condenser whose maximum value is 500 mmfd.  $L_1$  is an inductance which may be made by winding 68 turns of No. 26 wire on a two-inch bakelite form.  $L_2$  is the tickler coil and consists of 18 turns of No. 34 wire wound on the filament end of  $L_1$ .  $C_2$  is a small condenser for coupling some of the energy developed in the oscillatory circuit to the circuit in which resonance is to be determined. Usually a two-plate midget neutralizing condenser set at its minimum value is about right. M is a d.c. milliammeter reading not more than 2 mA. full scale. (The author used a Rawson meter

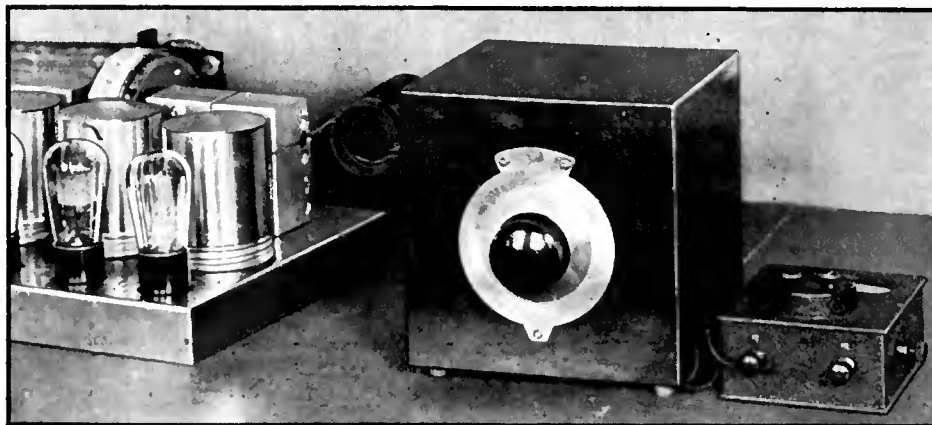

The line-up oscillator ready for action.

which cost \$15 but a much less expensive meter can be used—a Weston Model 301, for example—Editor.)

The apparatus is connected as shown. In connecting the tickler be sure that it is connected so that the circuit will oscillate. This may be determined easily by placing the finger on the grid connection of the

$C_2$ , is too large and its size should be reduced.

In a single-control receiver the tuning point of each circuit may be determined as follows. Clip the flexible lead from the coupling condenser of the oscillator onto the stator plates of the first tuning condenser in the radio set. Adjust  $C_1$  on the oscillator for the reaction point and record the reading on the oscillator condenser. Do the same with second, third, etc. tuning condensers in the radio set. During this process the tuning control on the receiver should be left fixed. If the adjustment of the oscillator condenser for each section of the tuning condenser is the same the circuits are properly lined up, if not an adjustment may be made to advantage. In this manner the line up of the tuning condensers in the radio set may be determined for any setting on the dial.

The theory of the line-up oscillator is briefly this: when the circuit  $L_1C_1$  is oscillating, the amount of grid current passing through the meter depends on the intensity of the oscillations. If any energy is taken from the oscillator the reading on the meter decreases. If coupling is obtained by any means to another tuned circuit this circuit will absorb the most energy when it is exactly in tune with the oscillator. Thus a reaction is obtained on the meter only when the two circuits are in tune. The reason for using only a small voltage on the plate of the oscillator tube is so the oscillatory current will be weak and any energy taken from this circuit may be observed easily on the meter.

Incidentally, the lower the resistance in the tuned circuit coupled to the oscillator the greater the amount of energy absorbed and the greater the reaction on the meter.

### List of Parts

The following is a list of the apparatus used in the writer's oscillator:

- One National Co. precision dial;
- One variable tuning condenser 0.0005-mfd ( $C_1$ );
- One coil wound as per instructions ( $L_1$ ,  $L_2$ );
- One tube socket;
- One CeCo tube, type A;
- One 440-ohm resistor, Electrad (R);
- One 0.5-mfd. by-pass condenser, Tobe ( $C_2$ );
- One Rawson meter, type 507A;
- One Two-plate neutralizing condenser ( $C_2$ ).

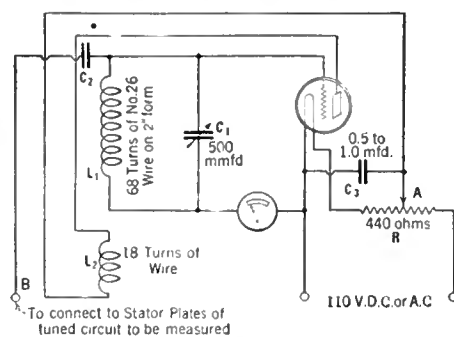
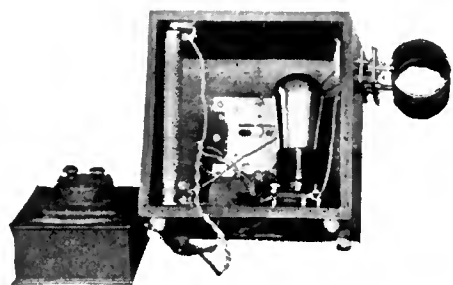

Fig. 1

tube whereupon the meter will show a small reading if the circuit is oscillating. Now adjust point "A" along the 440-ohm resistor until the milliammeter reads about 1.0 mA. and the oscillator is then ready for use.

### Operating Data

**T**O DETERMINE the resonance point of any tuned circuit in a radio set, clip the flexible lead which is connected to the small condenser,  $C_2$ , to the stator plates of the circuit under test. Turn the dial on the condenser  $C_1$  until the meter gives a sharp reaction. This reaction is a sharp lowering of the reading of the meter. Now adjust the condenser carefully until the meter is at its lowest reading and any adjustment either way increases its reading. It is necessary for accurate adjustment to have a vernier dial on the oscillator condenser, and at the same time one which may be read accurately. During this process the ground should be connected to the set. If the adjustment of the oscillator condenser is so broad as to cover more than a fraction of one division on the oscillator dial the coupling condenser,



Interior view of Mr. Browning's oscillator.



THE MAJESTIC MODEL 180 RECEIVER

Three stages of r.f. amplification are used in this Majestic receiver. The inductance associated with the antenna circuit is arranged so that it can be varied somewhat in order that this circuit may be brought into exact resonance with the other tuned circuits.

It should be noted that heater-type tubes are used throughout the set except in the power stage. It is also interesting to note that the phonograph pick-up unit is connected across the small tapped section of the first audio-frequency transformer.

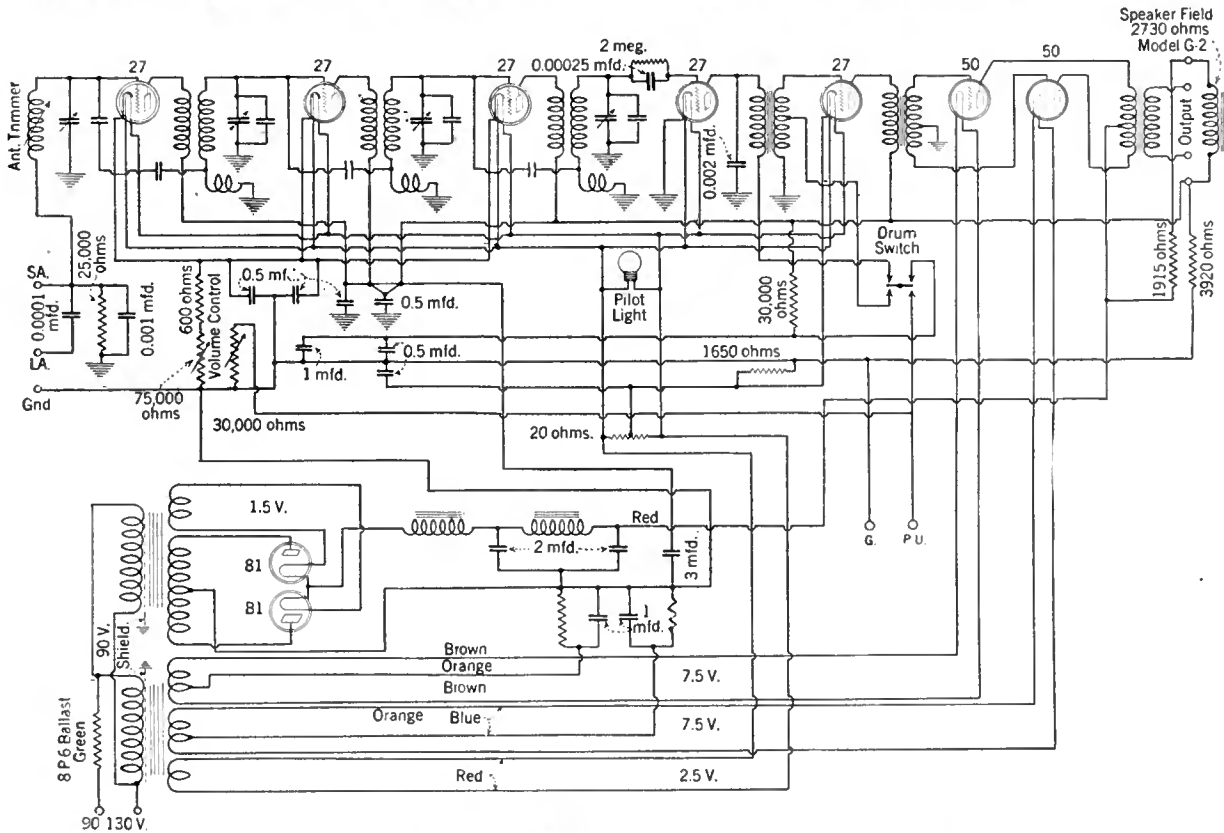

THE COLONIAL MODEL 31 A.C. RECEIVER

This receiver utilizes six a.c. tubes and a 280-type rectifier. It consists of two stages of r.f. amplification, a detector, and two stages of a.f. amplification, the output stage being push pull. Two re-

sistors, not indicated in the diagram but connected in series with the lead to the light socket, function as automatic voltage controls. The 30-ohm variable resistor is a manual adjustment.

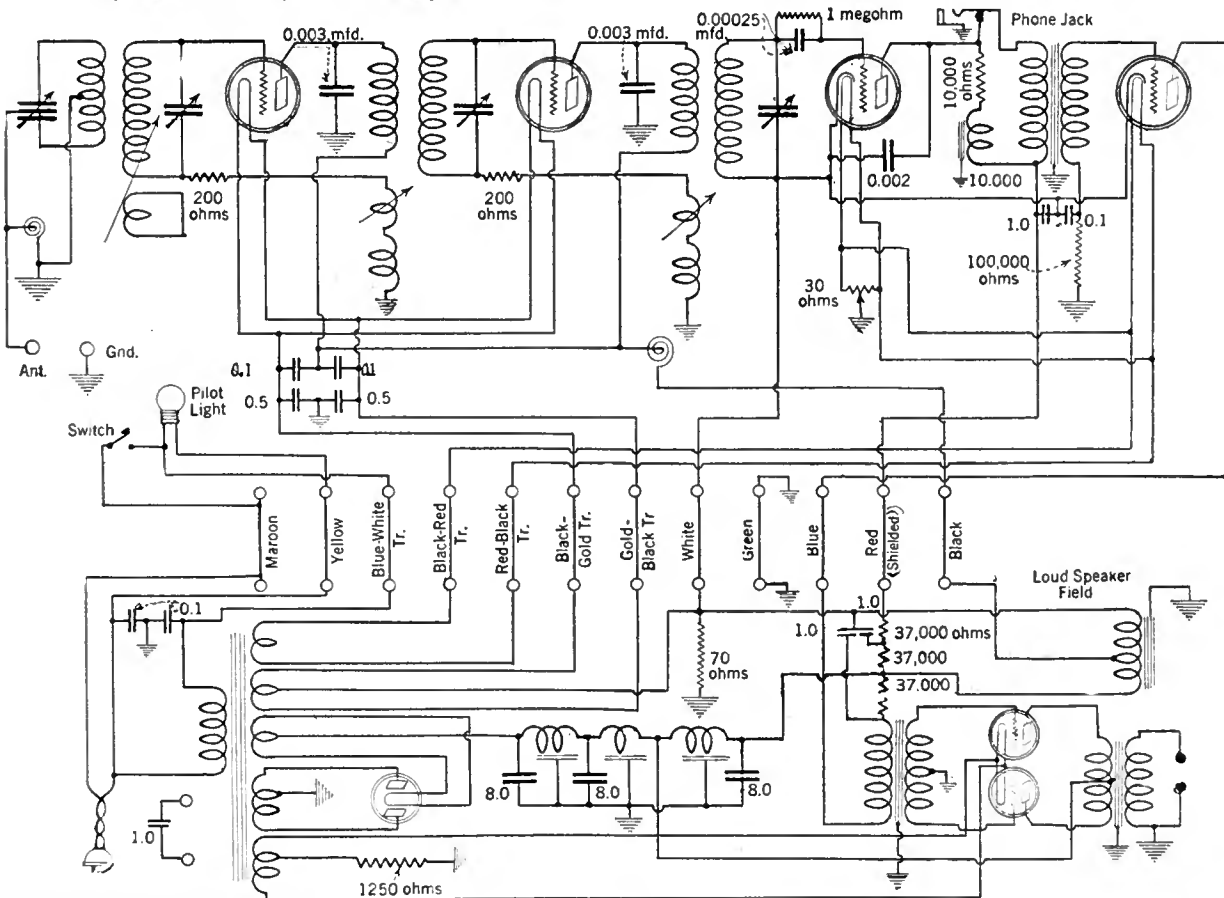

### THE SONORA MODEL A-36 RECEIVER

This receiver consists of four stages of tuned r.f. amplification, a grid leak and condenser detector, and a two-stage transformer-coupled audio-frequency amplifier. The set contains the following interesting features: combined electromagnetic and electrostatic

coupling in the r.f. amplifier, a special first-stage a.f. transformer phonograph pick-up, a push-pull output stage, an electrodynamic loud speaker, and an automatic control to compensate variations in line voltage.

**AVERAGE VACUUM TUBE AND LINE VOLTAGES FOR SONORA INSTRUMENTS**  
Models A-20; A-36; A-44; A-46

Line Voltages	125	120	115	110	105	
Primary Voltages across Transformer	87	84	82	50	77	
Radio Amplifier Tubes Type RA-1	Filament Voltage	16.0	15.6	15.2	14.8	14.4
	Plate Voltage	125	122	118	115	112
	Plate Current mA.	5.4	5.2	5.0	4.9	4.7
Detector Tube Type OC-1	Grid Bias Voltage	4.6	4.6	4.6	4.6	4.6
	Filament Voltage	2.4	2.3	2.2	2.1	2.0
	Plate Voltage	22	21	20	19.5	19
First Audio Amplifier Tube Type OE-1	Filament Voltage	2.4	2.3	2.2	2.1	2.0
	Plate Voltage	115	112	110	107	104
	Plate Current mA.	6.0	5.8	5.6	5.3	5.1
Push-Pull Audio Amplifier Tubes Type SO-2	Grid Bias Voltage	6.5	6.2	5.9	5.6	5.3
	Filament Voltage	7.9	7.7	7.5	7.3	7.0
	Plate Voltage	435	420	408	390	380
Plate Current mA.	47	45	43	41	39	
Grid Bias Voltage	87	84	80	77	73	

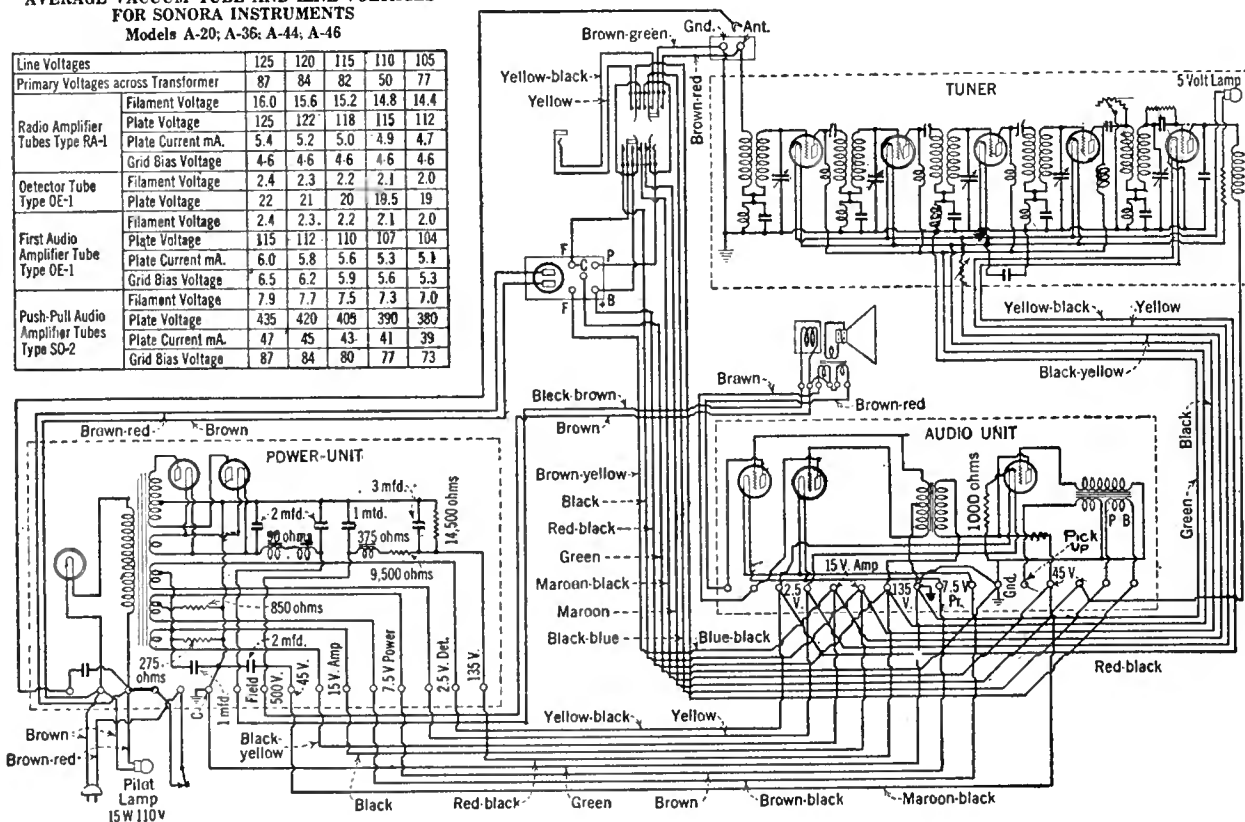

### FREED-EISEMAN RECEIVER MODEL NR-78 A.C.

The NR-78 is a completely a.c.-operated receiver using five heater tubes, two power tubes arranged in push-pull, and a full-wave rectifier. Unlike many other sets, the antenna stage in this receiver is tuned by means of a variometer in conjunction with a variable

condenser. Either a long or short antenna may be used. The set also contains a 1-mfd. condenser connected to one side of the power circuit so that the light socket may be used for the antenna by simply connecting together two binding posts.

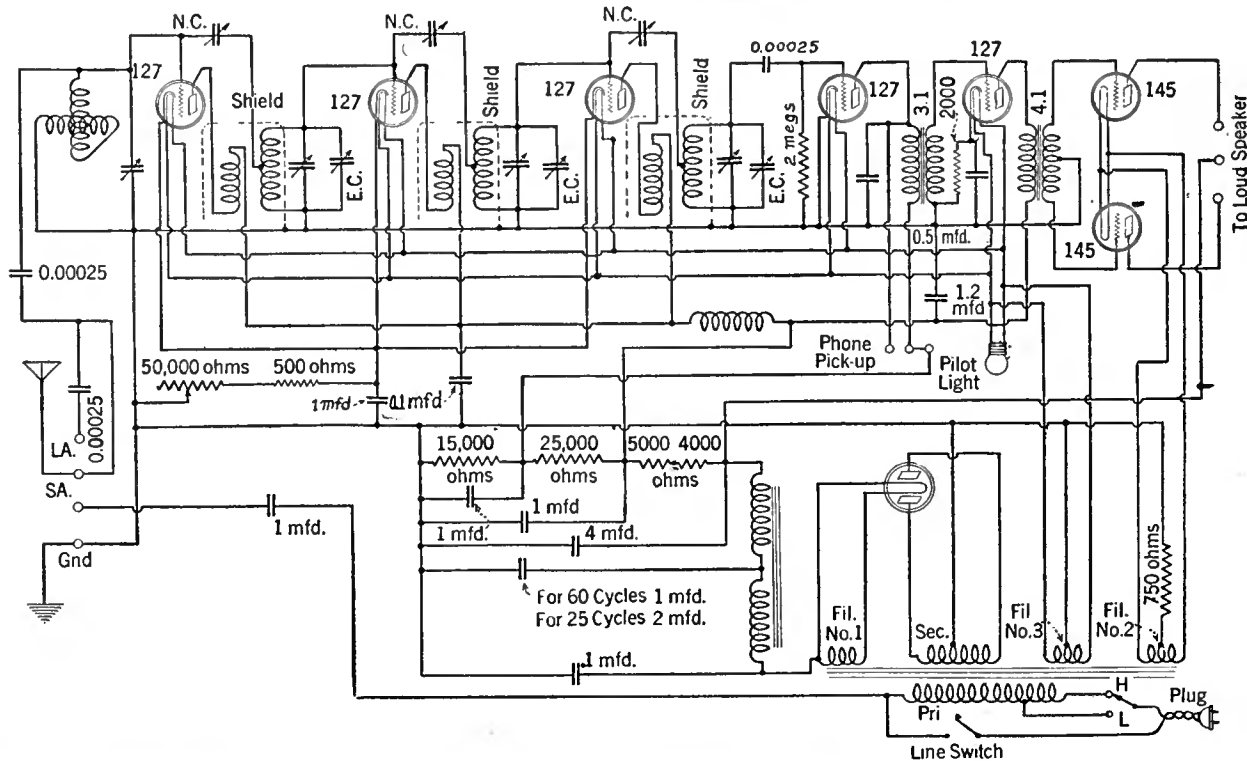

# NEW FEATURES IN THE SILVER RADIO

By McMURDO SILVER

President, Silver-Marshall, Inc.

## Features of Silver Radio

WHAT'S NEW in radio?" is the question that is being asked nowadays. Quite a few things are new in broadcast receiver design this year. One good way of answering the question is to review briefly the trends evident at the R. M. A. trade show, and to describe a typical example of a modern radio receiver employing a majority, at least, of these features. Such is the purpose of this paper; the new design trends which should be looked for in the 1929-30 season being listed below, while their application to a practical receiver is well exemplified in the Silver Radio chassis to be described in some detail.

- (a) The use of 221-type screen-grid a.c. tubes as both r.f. amplifiers and power detectors, to the probable almost complete exclusion of the 226- and 227-type tubes heretofore popular.
- (b) The general use of "band-selector" tuning as an aid in attaining the desirable ideal of a rectangular response curve, with its freedom from sideband cutting (attenuation of high musical frequencies).
- (c) The widespread use of 245-type tubes in push pull, feeding a high-grade dynamic loud speaker unit of improved response over the musical range of 50 to 5000 cycles, the amplifier having an undistorted power output of about three watts.
- (d) Automatic regulation of fluctuations in a.c. power line voltages.
- (e) A tendency to use smaller, or even self-contained, antennas for convenience, when receiver sensitivity permits.

In addition to these general trends in the design of all-electric broadcast receivers, and in addition to the fact that each season prices come down, or actual values given increase (which amounts to the same thing), certain other trends will be evident among a few manufacturers, as follows:

- (f) Use of but one a.f. stage following a power detector in sets where the attenuation of high frequencies resulting from the necessary high-ratio a.f. coupling transformer is not considered of as great importance as the cost saving resulting.
- (g) A tendency toward condenser loud speakers, not at all general, because of present poor efficiency, high polarizing voltages needed, excessive bulk, and fragility of existing types.
- (h) Use of so-called automatic tuning; as, for example, devices for selection of a small pre-selected group of stations by means of a multiplicity of buttons instead of the usual single selector knob.
- (i) Extension of the reproduced audio tone range up to 4000 or 5000 cycles to give naturalness and brilliancy, with the addition of an overtone cut-out switch to diminish high-pitched atmospheric noises in bad weather.

THE RECEIVER here described embodies all of the above features except f, g, and h, which will not be found in wide general application this year.

An article dealing briefly with the one radio stage trend, (f), will be found on page 15 of the May, 1929, RADIO BROADCAST. Another article, upon condenser loud speakers, (g), appears upon page 369 of the April, 1929, RADIO BROADCAST. Automatic tuning, (h), usually accomplished by mechanical selectors, is so simple as to require little special description.

At this stage of the radio art it is unfortunately difficult to make evident the merits of a receiver simply and concisely

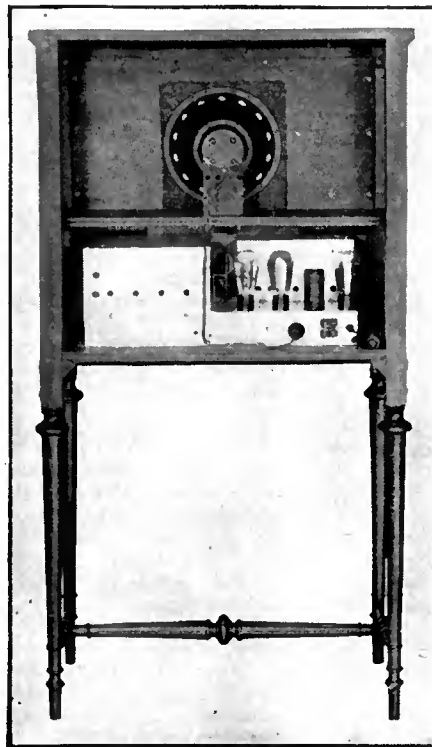

Fig. 1—Rear view of the new Silver Radio showing chassis and dynamic loud speaker.

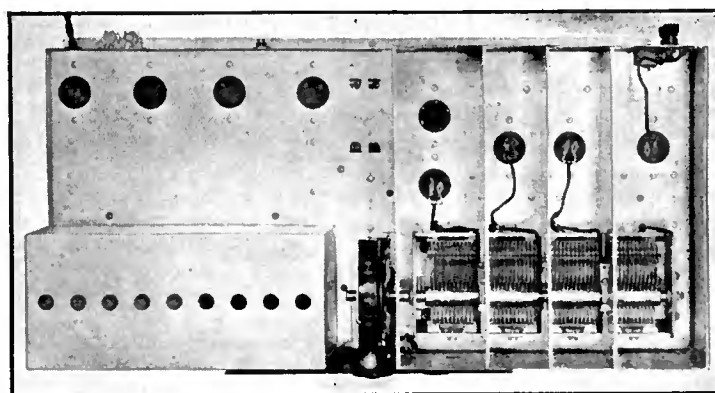

Fig. 2—The chassis of the Silver Radio with shield cover removed.

(as should be the case) by means of quantitative measurements, as few overall receiver measurement curves have been published (due in a large measure to the difficulty of making such measurements, even on older type sets). In presenting Figs. 3, 4, and 5 there is little data to compare them with and the curves must, therefore, be interpreted to be rendered readily comprehensible. Incidentally, it is to be hoped that, as overall measurements are now possible in any well-equipped radio laboratory, manufacturers will have more recourse to facts and less to fanciful "sales talks" for radio receivers in the future.

Fig. 3 illustrates the overall sensitivity of the set of Figs. 1, 2, and 3 under two different antenna conditions. Curve A is for the small self-contained screen antenna (8" x 24") attached to the bottom of the cabinet, while curve B is for a typical broadcast antenna of characteristics stated on the curve. The order of sensitivity shown is thought to be greater than that of any other receiver offered today. Measurements on typical six-tube, one-dial a.c. sets having three tuned circuits show an average sensitivity of forty to sixty microvolts per meter, and measurements on other sets of the same general type, having four tuned circuits (4 tuned r.f. stages), show about 15 to 20 microvolts per meter sensitivity. Considering curve n of Fig. 3, indicating an average sensitivity of 2 microvolts under standard conditions, the sensitivity of this set is seen to be about seven to ten times that of the typical t.r.f. set of four tuned circuits, and about twenty to thirty times that of the average three-tuned-circuit set. Suffice it to say that a sensitivity of 1.2 to 3.5 microvolts per meter, (the antenna input required to produce 50 milliwatts output, a purely arbitrary measurement standard) is sufficient to bring in almost any station audible above average prevailing noise levels. Comparative tests have furthered the belief that no more sensitive receiver may be used in the average home to-day.

## Overall Fidelity

IN FIG. 4 appear two overall fidelity curves for the receiver, taken at the middle of the broadcast band (1000 kc., 300 meters).

If the reader unthinkingly compares curve A with typical curves of audio amplifiers such as are often furnished to indicate the audio response characteristic of a radio receiver, this fidelity does not appear to be particularly startling. Here again, the dearth of overall fidelity measurements of existing receivers prevents the true excellence indicated by curve A from being appreciated at first glance. Referring again to a previous article in RADIO BROADCAST as one of the few sources of overall measurements that tell any real story of receiver merit, the reader's attention is called to the fidelity curve of Fig. 5, page 16 of the May

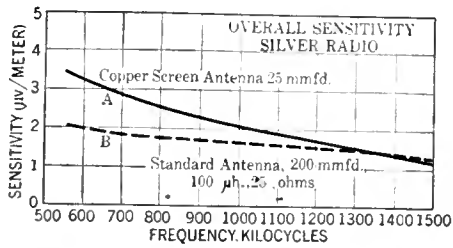

Fig. 3—Overall sensitivity curve of receiver: (A) with self-contained antenna. (B) with outside antenna.

issue. As both the sets to which measurements apply use the band-selector method of tuning for preservation of high tones, some idea can be gained of the terrible extent to which the average, ordinarily selective t.r.f. set (not employing band tuning) cuts sidebands; i.e., suppresses high musical notes. It is the writer's personal opinion that 999 out of every thousand radio listeners have no idea of what faithful reproduction of high audio tones in radio reception is—in other words, that no single receiver available in the past season reproduced tones in the neighborhood of 4000 cycles at even 50 per cent. of the value at which they were transmitted. This opinion is based upon many measurements and practical competitive tests between the set here described and other types. The holding up of the high end of curve A is, it is felt, as good an argument for band-selector tuning as could be asked for, particularly when the high sensitivity and selectivity indicated in Figs. 3 and 5 are considered.

Curve B of Fig. 4 indicates a possible concession to bad radio reception weather or locations. It shows the resulting overall fidelity of the receiver after an "overtone cut-out switch" has been set to cut a 0.001-mfd. condenser into the detector plate circuit to diminish response to high audio frequencies to a level comparable with that of ordinary commercial receivers. This provision is made for two reasons; individual listeners may prefer drummy, bass-accentuated reproduction, and in bad weather static, usually found in the higher audio tone ranges, may be diminished to make reception more enjoyable.

In Fig. 5 appears an overall selectivity curve, taken at 550 kc. It indicates that the frequency band passed is 10 kc. wide, at a level at which an interfering station would have to be ten times as strong as the desired station to produce equal volume (or, at which level the interfering one of two equally powerful stations would be only one tenth as loud as the desired one). At the level at which the interfering station would be reduced to one-one-hundredth of the volume of the desired station, the band width is 24 kc. To the average reader used to tuning sets of claimed "10-kc. selectivity," "knife-like sharpness," etc., such a curve is far from the ideal rectangle 10 kc. wide at its base. Again the dearth of overall measurements is the unfortunate reason for possible hasty misjudgment, for the fact remains that the degree of "apparent" selectivity indicated by Fig. 5 has, in practice, proven considerably greater than that of any commercial receiver so far tested. It should be noticed that the effective selectivity is independent of antenna size; i.e., the set does not "go broad" on a large antenna.

The Silver Chassis

THE STOCK Silver Radio chassis upon which the above measurements were made is illustrated in Fig. 2 and diagrammed in Fig. 8. Mechanically, it consists of a cadmium-plated steel chassis carrying,

at the left, an r.f. shielding case, with removable cover, divided into four compartments. In the left compartment is the antenna coupler, first r.f. tube, and first section of the four-gang tuning condenser. The second, third, and detector tubes, with their tuning condensers, are, respectively, in the next three compartments to the right. The detector compartment also houses the first-stage a.f. tube. Beneath the chassis, in four separate sections under the r.f. shielding case, are the coils, condensers, and resistors necessary to the r.f. circuits. At the exact front center of the chassis, is an illuminated vernier drum dial, with translucent scale marked directly in "telephone numbers" (kilocycles) for easy tuning. At the right rear is a steel case housing the power trans-

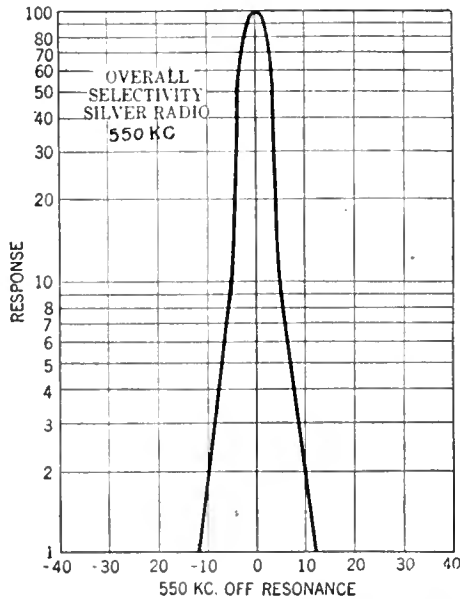

Fig. 5—Overall sensitivity curve taken at 550 kc.

former which furnishes all A, B, and C power for the set. In front of this case are, left to right, two 245-type power tubes, a socket for an automatic line-voltage regulator, and the 280-type rectifier tube. On the rear edge of the chassis appear a hum adjuster, a jack for a phonograph pick-up unit, speaker plug socket, and two sets of primary fuse clips. A single fuse, shifted from one set of clips to the other, allows omission or inclusion of the automatic line regulator, if required by power line fluctuations in any given territory. The dynamic loud speaker chassis is a

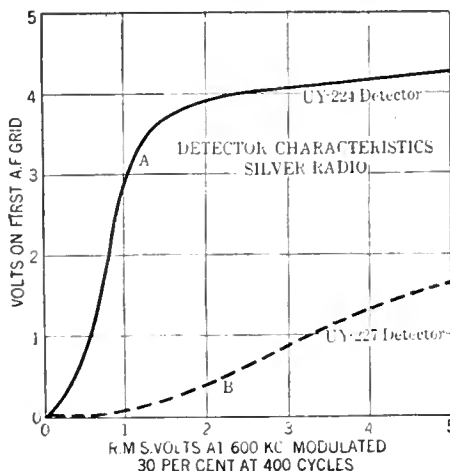

Fig. 6—The efficiency of a screen-grid detector as compared with that of a typical 227-type detector.

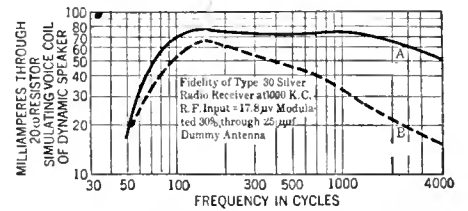

Fig. 4—(A) Overall fidelity curve of the receiver. (B) How the fidelity may be changed with the "overtone cut-out switch."

separate unit, connected to the set by means of a cable and a five-pin plug. Provision is made for but three external connections—antenna (if the self-contained screen collector housed in the cabinet is not used), ground, and power cord. The general mechanical construction is of a solid and substantial nature, reducing, and where necessary, simplifying, servicing problems to a minimum.

Electrically, the receiver consists of three stages of tuned radio-frequency amplification, using 224-type a.c. screen-grid tubes, the first and second stages coupled by a band selector. The r.f. amplifier is followed by a screen-grid power detector, resistance coupled to a 227-type first a.f. tube, which feeds a pair of 245-type power tubes in push pull through a 1:1 audio transformer. The power unit supplying all A, B, and C potentials is self-contained with the set and consists of a power transformer, a 280-type rectifier tube, filter choke, condenser bank and voltage-dividing resistors. The more interesting points can be explained most easily in reference to Fig. 8, the schematic diagram.

Uniform Sensitivity

AT THE left appear the antenna and ground binding posts, and the input coupler. This coupler is a small choke coil, so proportioned as to resonate with the self-contained screen antenna, just above the broadcast band (about 650 meters). This characteristic gives a voltage transfer curve from antenna to the first r.f. tube sloping downward from 550 to 200 meters. This is made much steeper than the gain curves of the following r.f. stages in order to compensate the cumulative steepness of the gain curve of the balance of the r.f. amplifier. This is one method, and the simplest, of evening up gain over the entire broadcast wave band (it is well known that the average t.r.f. amplifier gives greatest gain at the lowest wavelength in its range, and least gain at its highest wavelength). While other systems might have been employed to attain this end, the simplest method is always the most desirable in practice. The efficiency of the method is illustrated by curves A and B of Fig. 3, where the sensitivity is seen to vary in a ratio of less than 2:1 throughout the broadcast band under the most favorable conditions, and less than 3:1 under the most unfavorable—a not serious variation.

The first r.f. tube is coupled to the second through a band selector consisting of two separately tuned circuits so coupled as to produce a "humped" resonance curve of extremely steep sides and broad top. The second r.f. tube is coupled to the third, and the third to the detector, through transformers having untuned primaries and tuned secondaries. The secondaries of these transformers are identical with two band-selector inductances, and all are tuned by a four-gang condenser of extremely wide spacing, having individual compensators. The gain of all r.f. stages has been made equal, so that the curve of Fig. 7 is representative.

While the values of r.f. gain may appear low, as compared to the maximum that may be had from a single stage, they are about as high as may safely be obtained stably in production, and result in an overall gain of as high an order as can be used in practice.

The r.f. circuits are isolated by means of by-pass condensers, resistors, and chokes to a point where the only coupling existing to cause oscillation is the input to output coupling, and this has been effectively eliminated by grounding, not only the set chassis, but the loud speaker frame as well. In isolation, the matter of defining accurately all r.f. current paths, and avoiding the use of the metal chassis as a common path, was found most important. The r.f. tubes are operated at plate potentials of about 170 volts, with screen voltage variable from zero to 67 volts for volume control. C bias is obtained automatically by means of individual resistors common to grid and plate returns. The r.f. amplifier does not oscillate, being completely stable under all conditions of operation.

**Power Detection**

**I**N THE past the 227-type tube operated at a high plate voltage and with a highly negative bias (so-called "power detector") has been considered the most generally satisfactory detector available. In this set, a new detector is used—a screen-grid power detector of such high efficiency that it is probable that within a short time it will replace all other types of detectors. Its conversion efficiency (r.f. signal modulated 30 per cent. at 400 cycles to a.f. signal at first audio grid) is illustrated clearly in Fig. 6 at A as compared against a typical 227-type power detector at B. A comparison of the respective slopes indicates the great superiority of the screen-grid detector, which was operated with a 60,000-ohm bias resistor, a total B potential of 170 volts, and a plate resistor of about 300,000 ohms. A particular point to be noted is the flattening off of the curve at increasing signal voltages. This occurs at such a point as to prevent serious overloading of the audio amplifier, for it has been found that such "distortion" as exists is of a volume limiting nature, and is far less annoying than overloading of the power audio stage—the detector characteristic, therefore, serves as a means

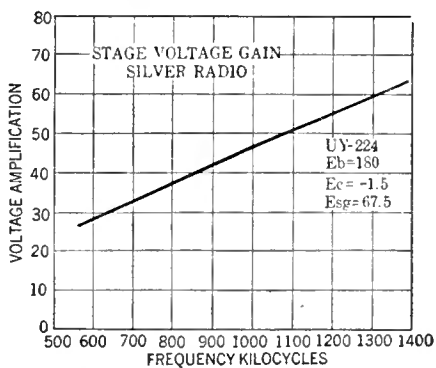

Fig. 7—Curve showing r.f. gain of receiver.

of automatically regulating volume to prevent annoying audio-overload distortion (easily possible, for the sensitivity is so great that a fair signal can easily be built up to far more than the 3-watt undistorted output of the power stage). While the 224-type detector has been used in the power "detector" circuit, no need exists to take advantage of its maximum output because of the use of two a.f. stages. As the detector tube has a very high plate resistance, about the only really practical method of coupling it to the first audio tube is by means of resistance coupling, which is used. The "overtone switch" previously mentioned cuts a 0.001-mfd. condenser into the detector plate circuit to diminish the high tones when desired. As the phonograph pick-up jack is in the first a.f. grid circuit, an external transformer is needed to produce maximum volume.

The push-pull stage is coupled to the dynamic loud speaker through a transformer having an excellent transmission characteristic. The loud speaker head itself shows very uniform conversion from 50 to 5000 cycles. It is baffled in order to avoid cabinet resonances, and likewise to avoid howling due to mechanical vibrations, being coupled to the detector tube.

**The Power Supply**

**T**HE POWER SUPPLY unit employs but one choke, of very high inductance, the dynamic loud speaker field acting as the second choke. The field is connected just after the rectifier tube, at a point

where about 100 mA. is flowing through the filter. A portion of this current is by-passed around the field by a 1500-ohm resistor, the actual voltage drop across the field being about 70 volts, a value producing the desired excitation. This allows the second choke to be of unusually high inductance with corresponding filtration. The detector and r.f., first a.f., and second a.f. plate voltages are all taken off the voltage-divider system at different points, in order to provide isolation sufficient to obviate any possibility of the "motor boating" which is apt to occur in audio amplifier circuits showing as good low-frequency transmission as do those of this receiver. For convenience, the filaments of the 245-type tubes are excited from a separate filament winding on the power transformer, which is provided with an electrostatic shield to cut out r.f. noises which might otherwise get into the receiver through the power lines.

**RADIO IN N. Y. SCHOOLS**

**T**HE FIRST demonstration of a new system of "centralized radio" for schools took place recently in the New Utrecht High School of Brooklyn, before 2500 students, music supervisors, educators, architects, and officials of the New York City Board of Education. The demonstration was arranged with Stanley & Patterson, Inc., a sales agent of the Radio-Victor Corporation of America, at the invitation of Stephan A. Thomas, chief of the electrical division of the Board of Education, and with the cooperation of Dr. Harry A. Potter, principal of New Utrecht, to provide educators with an opportunity of observing at first hand, the operation of a radio system especially adapted to school use.

The auditorium of the high school was wired with a single-channel control panel, hooked up to a master receiver combined with an electric phonograph, and an arrangement of ten dynamic loud speakers located in the wall organ recesses. Additional loud speakers were installed in Dr. Potter's office, and in the boy's gymnasium. As many loud speakers as are desired in the various classrooms may be connected to the master control panel, without any mechanical changes in the centralized radio system. A time clock automatically starts and stops the programs.

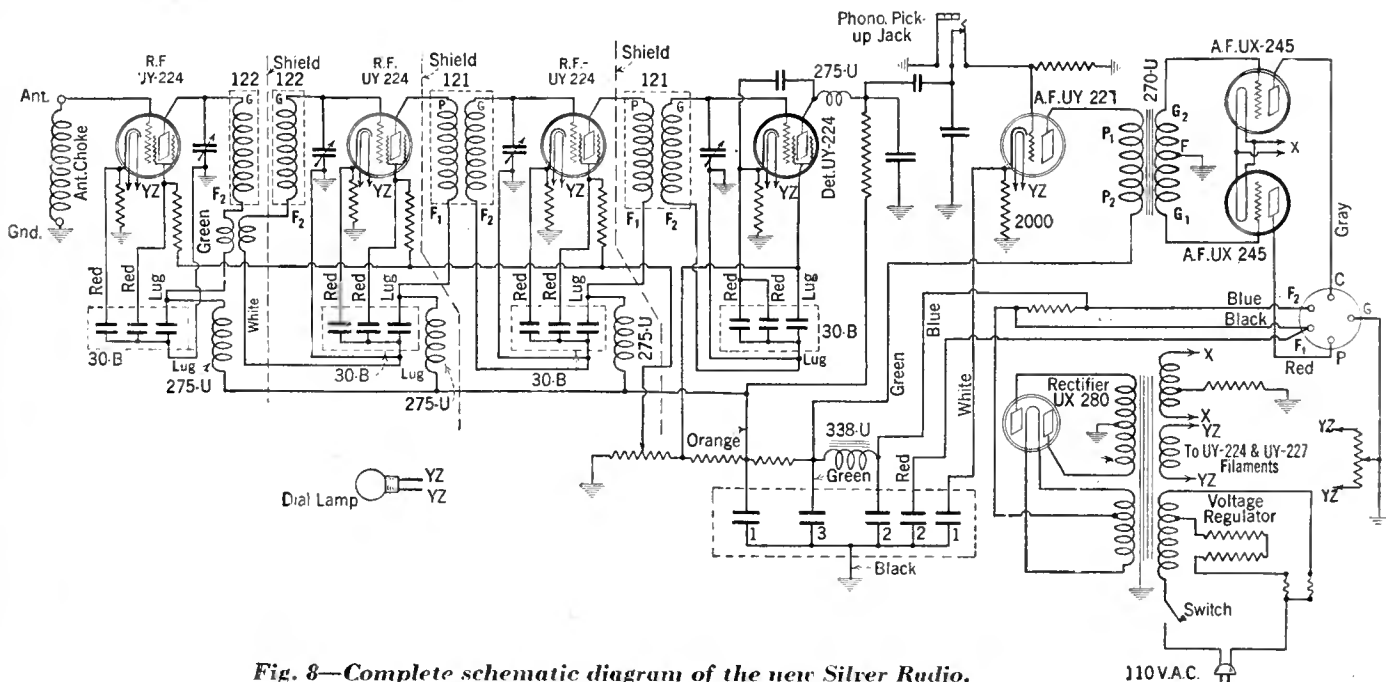

Fig. 8—Complete schematic diagram of the new Silver Radio.



# WHY A.F. TRANSFORMERS BURN OUT

By HERBERT M. ISAACSON

PERHAPS THERE are many who have wondered with the writer why transformers "burn out." Why the transformers in one set will stand up indefinitely, and yet transformers of the same make will break down frequently in a different set. That a transformer of "X" make should last longer than one manufactured by "Y" might be accounted for in a number of ways. Fiber is almost always used as the insulating material between the core and the primary, and between the primary and the secondary. In addition, the terminal mounting strip of many transformers is made of fiber; and fiber almost always contains traces of acid. "Y" transformers might invariably break down more frequently than "X" transformers, because the fiber used in them contains more acid, which, of course, eats the fine copper wire away. But, that transformers of "X" make should on the average last five times longer when used in sets made by "A" than they do in sets made by "B", as has been found by the writer, indicates the presence of factors, outside of the transformers, that affect their life.

Some time ago, the writer returned to the manufacturer for replacement, a transformer with an open primary, mentioning that it had been in use in a conventional two-stage amplifier, using double-circuit jacks in both stages. The manufacturer wrote back saying the open was undoubtedly caused by "surges" set up when the plug was removed from one jack and inserted in another; that if automatic filament jacks were not used, then the set should be shut off before plugging from one stage into another, to prevent these surges.

Now, the fusing point of No. 40 wire, the size ordinarily used in a.f. transformers, is 1.85 amperes. The d.c. resistance of the average primary is 2000 ohms. To cause a current of 1.85 amperes to flow through this winding, a terminal voltage of 3700 would be necessary—6845 watts!

[This is an interesting calculation but it neglects the possibility that comparatively high voltages may be developed across an inductance, such as an audio transformer,

if the circuit is suddenly opened. These voltages do not depend upon the impressed voltage but are directly a function of the inductance of the circuit and the rate of change of current. If the circuit is opened quickly the rate of change in current will be high and comparatively large voltages will be produced across the transformer. The current would not be greater than the normal plate current of

*Mr. Isaacson, who is a member of the QRV Radio Service in New York City, has discovered a very interesting fact regarding audio transformers: namely, the way in which the unit is connected in the circuit has an important effect on its life. Therefore, the next time one of your transformers "goes west," examine the diagram of the receiver before blaming the manufacturer.*  
—THE EDITOR.

the tube but the voltages will be greater and the transformer might arc over at some point. If this occurred frequently enough the conductor would finally break at the point where the arc takes place. This is undoubtedly the effect which the manufacturer had in mind when he spoke of "surges."—*Editor.*]

Recently, the writer took apart a large number of defective transformers of a certain make. About half of them came from sets of one make and the other half from sets of a different make. In "A" sets the cores were grounded. In "B" sets they were not. The transformers in "B" sets had lasted about five times longer than those in "A" sets. In unwinding the primaries, it invariably was found that in those transformers that had their cores grounded, the first few layers of wire nearest the core were eaten away; in those transformers with ungrounded cores, there was no regularity in the position of the lesion. Apparently the grounding of the cores was an important factor in determining the life of the transformer. But why?

If we have two conductors at a potential difference, immersed in a conducting solution known as an electrolyte, electrolysis will take place. The action is, briefly, as follows: The electrolyte is made up of positive and negative ions. Ions are atoms holding charges of electricity. The conductor which is maintained at a positive potential with respect to the other is the anode. The negative terminal is the cathode. Due to the law of attraction of unlike charges, the positive ions are attracted to the cathode. When a positive ion reaches the cathode, its charge is neutralized by it, and it becomes an atom, which in the case of copper is deposited on the cathode. Under certain conditions the positive copper ions of the anode material go into the electrolyte and are carried to the cathode. The effect of all this then is a tearing down, a disintegrating of the anode, the positive conductor, and the building up of the cathode, the negative

conductor. The process is electroplating and is also what takes place in our transformer.

The primary of our transformer is the anode. It is connected to the positive post of the B battery. Anything connected to the minus post, very often a metal chassis or metal panel, is the cathode. Moisture constitutes the conducting path, the electrolyte. As has just been shown, under the stimulus of the B voltage, the copper wire of the primary will be disintegrated and deposited on the metal chassis and panel. The rate of electrolysis is proportional to the current flow through the conducting moisture path. The current is inversely proportional to the resistance of the path, which in turn is proportional to its length, assuming that the path is of uniform resistance. And here is where the grounded core enters.

The grounded core is a cathode, separated from the first few layers of the primary, an anode, by a very short distance (see Figs. 1 and 2). Assuming that it is twenty times nearer than any other cathode, electrolysis will then take place twenty times faster, which means that, other factors being the same, the transformer with a grounded core will have a life only  $\frac{1}{20}$  as long as one with an ungrounded core. Incidentally this electrolysis goes on all the time the primary is maintained at a positive potential, which, in the case of a battery-operated set, is all the time, whether the set is turned on or not. In the case of sets securing B voltage from the house current, it takes place only while the set is turned on.

Now that the cause of transformers becoming defective is known it is important to discover a satisfactory method of overcoming the trouble. It is well known that in many a.f. amplifier circuits it is essential to ground the cores of the transformers in order to obtain satisfactory operation. However, it will be found that in most cases the same stabilizing effect may be obtained by connecting the core to the positive B wire, and this would place the core at the same potential as the primary (inside) winding, thus effectively preventing electrolysis.

The next time an a.f. transformer in your set "goes west," don't be too quick to blame it on a voltage surge; the trouble probably has been caused by the processions of millions of atoms of copper, each bearing its charge of electricity, hurrying to a "Happy Hunting Ground" called the cathode—minus B in the vernacular—there to give up its charge, its mission having been accomplished.

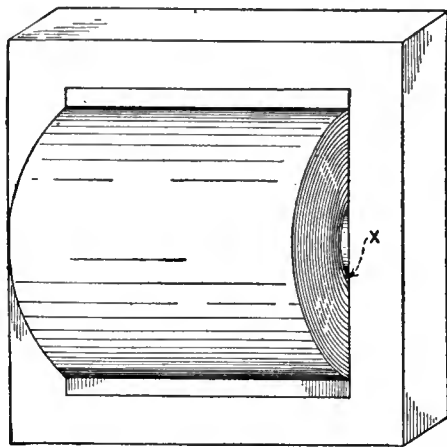

Fig. 1—The point marked "X" in this drawing shows where electrolysis takes place in an a.f. transformer.

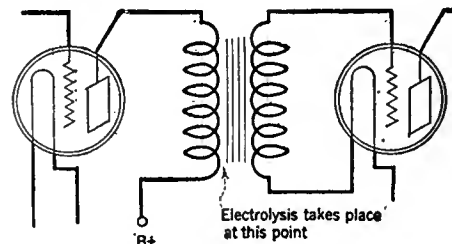

Fig. 2—The arrow in this circuit diagram indicates where transformers are apt to burn out.

## THE EXPERIMENTER'S ARMCHAIR

By ROBERT S. KRUSE

**B**EFORE GETTING down to the main discussion I should like to make a suggestion as to the usefulness of dividing one's wavemeters into two classes. A good example is found in the practice of the Radio Frequency Laboratories, Inc. The precision meters of this establishment are reserved for precision work; during the preliminary adjustments simple and convenient knockabout wavemeters, such as shown in the picture (Fig. 1), are used. If one of these is damaged replacement and recalibration are easy and prompt. To save guesses, I will explain that the two large coils are wound on General Radio type 277U forms, the variable condensers are of National Company make, and the two smaller coils are of 3-16th-inch copper tubing. The long baseboard not only carries a calibration chart but also provides room for the long insulating shaft and the National type A vernier dial which materially facilitate readings. The wavelength ranges in meters in this case happen to be 1.85—6.1, 5.5—27.2, 25.0—122.5, and 118.0—565.0. Lamps are placed in the tuned circuit of the two larger wavemeters but are omitted from the smaller ones for the obvious reason that their inductance would be a considerable proportion of the total and would be changed on replacement of the lamps.

### WAVELENGTH VS. FREQUENCY

The wavemeter charts are in dial setting against wavelength—not frequency. This recalls a discussion held last month. A group of six experimenters agreed thoroughly that frequency was logical as a basis for calculation but was not equally convenient for measurement, and amounted to a positive difficulty during rough preliminary work. The point is, of course, that wavelength is related to the size of things while frequency bears an inverse ratio. During the preliminaries much time is saved if one may estimate the needs without the mental contortion of taking reciprocals of everything. If one insists on talking frequency the only way to avoid such a thing at every turn is to think in reactances instead of inductance and capacities. This in itself involves some detours.

At short waves it is furthermore an infernal nuisance to say "Sixty-thousand kilocycles" when "5 meters" will do just as well. I was quite tickled to find that from the Bell Telephone Laboratories there emerged the same opinion and this was printed in the *I. R. E. proceedings*. I am not quite sure whom the joke is on because one of our *I. R. E. Committees* has proscribed the meter—and I belong to the Committee!

Incidentally, if frequency is preferred lubberly numbers may be avoided by speaking in megacycles whenever dealing with the territory below (I have fallen back on wavelength again) the ordinary broadcast band. I believe Dr. Pickard is the sponsor of the megacycle terminology. It is in sufficiently general use now so that

a complete change-over should be quite painless. What are the opinions of the congregation?

### Thirty-Megacycle Reception

**L**ET us get down to the main topic. Our material this month comes from C. A. HART, whose location has been in rapid succession at San Diego, New York, San Pedro, and wherever else the U. S. S. *California* has gone. The corre-

when coupling in the customary amateur manner through a condenser connecting the lower end of the antenna to the upper, or grid, end of the tuned circuit. Therefore, magnetic coupling was used with a primary coil of three times the diameter of the secondary. With a 30-foot antenna adequate coupling is obtained when this coil is placed about 1½" from the secondary, whereby the capacity effect is made sufficiently small so that the differences between various thirty-foot antenna's are of no consequence. One accordingly needs to carry only a 30-foot piece of wire and put it up in any convenient manner which will keep it reasonably clear of things. The teeth of the regeneration control were drawn by the simple expedient of cutting and trying until a combination was obtained which permitted leaving this control entirely alone while at the same time giving continued smooth oscillation when tuning across the whole scale. This is in line with the sound amateur tradition of throwing out those things which make trouble. The necessity of doing this while not forcing the tube accounts for the abnormal tickler. The regeneration condenser size is not stated but a small photograph suggests that its capacity runs to several hundred micromicrofarads.

To secure uniform operation across the tuning range the single-layer chokes common to transmission were avoided in favor of a type likely to give a broader response though possibly not of as high an impedance. Three pairs of 1" bakelite squares were strung on a quarter inch bakelite rod. These were located so as to form three slots ⅛" wide and ½" apart. In the narrow slots were placed scramble-wound, windings consisting of 100 turns each of No. 28 s.c.c. wire, the three windings being connected in series. Smaller wire in the same form proved inferior.

With this combination smoother oscillation was produced than with any combination using higher filament voltages and smaller regeneration capacities in the usual manner. The detector plate voltage had to be kept up to 90 and a 5-megohm grid leak was used. The a.f. stages were run at lower plate voltage than the detector. Concerning this point Mr. Hart says "This may be explained by quoting from Van der Bijl's *Thermionic Vacuum Tubes*, page 214. 'The higher plate potential, of course, gives a higher amplification because the plate resistance of the tube is lower. It is seen also that the amplification at 1000 meters is about 3 times as large as the amplification at 100 meters.' Since without amplification there can be no oscillation, it follows that for 10 meters or less the plate potential must be high."

With this receiver changes of filament voltage such as ordinarily made had very slight effect on the beat frequency, which is unusual for such receivers. The noise level was lower than the other receivers used in the 15-40 meter region, probably because of the loose magnetic primary

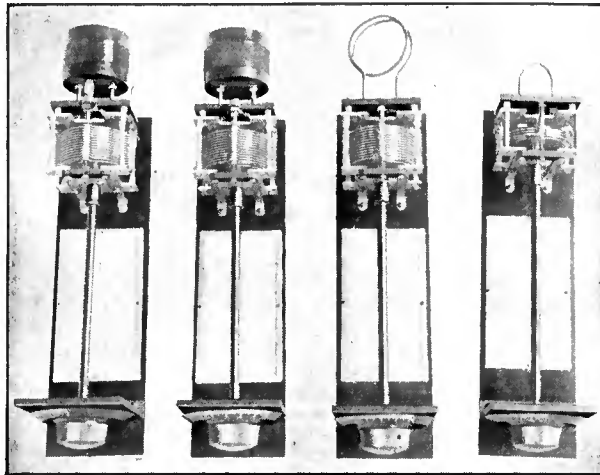

Fig. 1—Knockabout wavemeters are used at the Radio Frequency Laboratories for preliminary adjustments. This picture shows four such instruments of different wavelength ranges.

spondence has accordingly taken some time to develop what follows. Let us first look at Mr. Hart's experiments.

A receiver was built up with the conventional oscillating detector and a.f. amplifier for the purpose of going somewhat into the necessities in the region of thirty megacycles. Because such receivers are notoriously weak as to holding calibration, the next step may seem surprising, but this will be explained presently. The curve of Fig. 2 was made by heterodyning the receiver with a crystal-controlled driver. It will be seen that the range of the receiver was from 27.62 megacycles to 45.16 megacycles (10.85 meters to 6.64 meters). For this range the grid coil consisted of one turn and the tickler of 2½ turns of No. 18 enameled wire wound on a standard UX tube base and tuned by a "5-plate" variable condenser. The lengths of connecting leads are shown in the insert diagram of Fig. 2. The ability to take and hold calibration requires the removal of tuning effects from the operator's hands, the antenna, and the regeneration control. If really good permanence of calibration is desired one must also be careful to avoid changes due to shifts of filament and plate voltage, the commonly neglected changes in ordinary r.f. chokes, and, of course, one must keep (and not mistreat) the same tube.

Hand capacity was removed by the use of extension controls rather than shielding. The effect of antenna variations or of changing to another antenna is very large

coupling. The suggestion made above that magnetic coupling gives a better signal-noise ratio than the usual amateur method of capacity coupling to the end of the antenna was confirmed on some previous experiments on higher wavelengths by enclosing the primary in a metal box with a 2" hole facing the secondary coil. This permitted magnetic coupling but static coupling was prevented by an ordinary static screen of insulated wire hanging vertically across the hole. The upper end of each wire was secured to the metal box and the lower end hung free. Doubtless the same result would have been secured at 10 meters.

COMMENTARY

It will be seen that Mr. Hart's set departs widely from current short-wave practice of using a large ratio of C/L in the tuned system. For his particular purpose a wide tuning range was desired but the very great merits of a high C/L ratio can be retained while securing a more open tuning scale by merely putting most of the capacity into a fixed form as was suggested in a previous "Armchair" discussion. A 16-megacycle tuning range without variation of the regeneration control is far beyond that ordinarily obtained in short-wave receivers which rarely manage to go a tenth that far and, there-

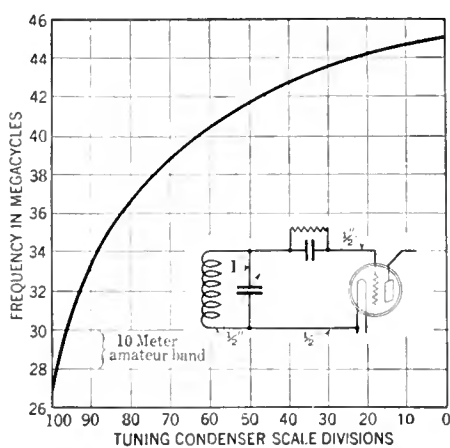

Fig. 2—Calibration curve of Mr. Hart's 30-megacycle receiver. Insert diagram shows lengths of connecting leads.

fore, rarely are fit for calibration. The signal strength for a well-made oscillating receiver seems (and measures) unchanged by large alterations in C/L. The choke used has undoubtedly a capacity reactance at 10 meters which would be very unfortunate in circuits of conventional proportions but in this case is of distinct advantage.

The absence of shielding is intentional. Since frequent alterations were to be made in the set, a shielding system would have been troublesome during the first stages. Most builders of short-wave receivers entirely fail to appreciate that shielding is useful *only* if there are no circulating r.f. currents in the shield and if the wires emerging from the shield are effectively bypassed and choked. This means that the apparatus inside the shield must connect to the latter at *one point only*, and that much thought must be given to the location of that point, the bypasses, and wires going to it. Frequently the easiest solution is to place a metal sheet inside the shield to which these things are connected and which, in turn, touches the shield at only one point. This is a rudimentary double shield. At very short waves bypasses are not to be judged by their capacity but by their inductive reactance. Paper condensers of 1 microfarad capacity are frequently much less effective than a small mica "postage-stamp" unit of a hundredth the capacity. Chokes, if placed outside the shield, have missed a part of their function and if placed inside may easily reverse it and collect r.f. power which the wire alone would not have intercepted. Again double shielding is indicated as the most desirable solution to the problem.

## SKIP-DISTANCE AND RANGE TABLE

For frequencies between 1500 and 30,000 kc.

(This table was prepared especially for RADIO BROADCAST by L. C. Young, Naval Research Laboratory)

Frequency in Kilocycles	Approximate Wavelength in meters	Range of Ground Wave	SKIP DISTANCE				MAXIMUM RELIABLE RANGE				SERVICES (International Radio-telegraph Convention)	REMARKS
			Summer		Winter		Summer		Winter			
			Day	Night	Day	Night	Day	Night	Day	Night		
1500—1575	200—175	100	—	—	—	—	100	100	150	300	Mobile	1601 Experimental— 1600-1652-1664- 1680-1704-1712 Portable.
1715—2000	175—150	90	—	—	—	—	120	175	170	600	Mobile—Fixed— Amateur	U. S. Entirely Ama- teur.
2000—2250	150—133	85	—	—	—	—	130	250	200	750	Mobile—Fixed.	U. S. 2002 to 2300 Exp. visual Broadcasting
2250—2750	133—109	80	—	—	—	—	150	350	220	1500	Mobile	2398 Experimental
2750—2850	109—105	70	—	—	—	—	170	500	300	2500	Fixed	2750 to 2950 Exp. Visual Broadcast
2850—3500	105—85	65	—	—	—	—	200	900	350	3000	Mobile—Fixed	3088 Experimental
3500—4000	85—75	60	—	—	—	—	250	1500	400	4500	Mobile—Fixed— Amateur	U. S. Entirely Ama- teur.
4000—5500	75—54	55	—	—	—	—	300	4000	500	7000	Mobile—Fixed	4795 Experimental.
5500—5700	54.0—52.7	50	—	—	—	—	400	4000	600	8000	Mobile	
5700—6000	52.7—50.0	50	50	50	50	60	150	5000	650	8000	Fixed	
6000—6150	50.0—48.8	50	60	70	60	90	500	5500	700	8000	Broadcast	
6150—6675	48.8—45.0	45	70	115	80	175	550	6500	750	8000	Mobile	
6675—7000	45.0—42.8	45	80	185	100	290	650	7000	820	8000	Fixed	
7000—7300	42.8—41.0	45	90	220	115	360	700	7500	900	8000	Amateurs	
7300—8200	41.0—36.6	40	140	290	175	465	750	8000	1100	8000	Fixed	
8200—8550	36.6—35.1	40	160	370	200	570	800	8000	1300	8000	Mobile	
8550—8900	35.1—33.7	40	170	420	230	630	900	8000	1460	8000	Mobile—Fixed	
8900—9500	33.7—31.6	40	200	485	270	710	950	8000	1680	8000	Fixed	
9500—9600	31.6—31.2	40	220	530	280	740	1000	8000	1820	8000	Broadcast	
9600—11000	31.2—27.3	35	260	625	325	860	1100	8000.	2140	8000	Fixed	
11000—11400	27.3—26.3	35	300	750	380	1000	1200	8000	2460	8000	Mobile	
11400—11700	26.3—25.6	35	315	800	400	1080	1300	8000	2700	8000	Broadcast	
11700—11900	25.6—25.2	35	335	835	420	1120	1500	8000	2800	8000	Fixed	
11900—12300	25.2—24.4	30	350	870	430	1170	1550	8000	3000	8000	Fixed	
12300—12825	24.4—23.4	30	370	940	460	1240	1600	8000	3200	8000	Mobile	
12825—13350	23.4—22.4	30	390	1000	485		1700	8000	3440	8000	Mobile—Fixed	
13350—14000	22.4—21.4	30	420	1075	510		1800		3660	8000	Fixed	
14000—14400	21.4—20.8	30	440	1150	545		1950		4060	8000	Amateurs.	
14400—15100	20.8—19.85	30	460	1230	580		2200		4360	8000	Fixed	
15100—15350	19.85—19.55	30	475	1300	610		2300		4610	8000	Broadcast	
15350—16400	19.55—18.30	30	500	1370	640		2500		5060	8000	Fixed	
16400—17100	18.30—17.50	25	550		700		3000		5600	8000	Mobile	
17100—17750	17.50—16.90	25	580		740		3500		6200	8000	Mobile—Fixed	
17750—17800	16.90—16.85	25	600		755		4000		6450	8000	Broadcast	
17800—21450	16.85—14.00	20	660		835		5000		7000	8000	Fixed	
21450—21550	14.00—13.90	20	750		1050		6000		7000	8000	Broadcast	
21550—22300	13.90—13.45	20	780		1090		7000		7000	8000	Mobile	
22300—23000	13.45—13.10	20	835		1130		7000		7000	8000	Mobile—Fixed	
23000—28000	13.10—10.70	15	900		1200		unknown		unknown	8000	Not reserved	Good only for few hours during day- light.
28000—30000	10.70—10.00	10	1000		1400		unknown		unknown	8000	Amateurs	

NOTES: Mobile: Ships and Coastal Stations, Aircraft, Railroad Stock, etc. Fixed: Permanent stations handling point to point traffic. Skip Distance: Shortest distance beyond the ground wave at which communication is possible, or the point where the sky wave first comes to earth. On certain frequencies and at certain seasons communication is possible within the skip distance due to echoes and around-the-world signals.

The above table was obtained from the general average of a large number of observations. For the night ranges given it is assumed that the greater part of the path between the transmitting and receiving stations is in darkness. As the distances given in this table are general averages many discrepancies may be found in practice due to seasonal changes, sun spot activities, geographical location, local weather conditions, etc.

# A Tube Making Possible Many Economies

## ENGINEERING FEATURES OF THE UX-245

By F. H. ENGEL

Technical and Test Department, Radio Victor Corporation



F. H. Engel

THE UX-245 is a power amplifier which has been developed to meet the demand for an output tube which would permit the manufacture of broadcast receivers having good tone quality and reasonable volume at a price well within the reach of the average purchaser. Heretofore,

the medium-priced receiver has been limited to the use of the UX-112A and UX-171A types of output tubes, and, while the fidelity of reproduction was satisfactory, the volume obtainable with these types was, in many instances, not considered sufficient for all purposes. Receivers utilizing UX-210 or UX-250 tubes are inherently above the middle-priced range so that a gap has always existed between the medium-priced, good-fidelity, low-volume receivers and the high-priced, good-fidelity, high-volume receiver. The UX-245 tube is intended to fill this gap.

The electrical rating of the UX-245 tube is as follows:

Filament volts.....	2.5
Filament amperes.....	1.5
Plate volts.....	250

Some misunderstanding has existed in the past regarding the voltage ratings of tubes so that a few words in explanation will not be amiss here. The filament voltage rating of a Radiotron, for example, as given in the instruction sheet accompanying each tube, is a normal value, i.e., optimum set performance and life will be obtained when the tube is operated at its rated (normal) value. This means that receiving sets operating on socket power should have transformers or resistors in the filament circuit which are designed to operate the filament or heater at rated value under average line voltage conditions. A reasonable amount of leeway is incorporated in the tube design so that ordinary line fluctuations downward will not cause undue loss of electron emission and appreciable decrease in set performance. In the normal voltage range the filament of the UX-245 tube operates at a

dull red color and, with normal plate voltage and grid bias, the sturdy, coated filament gives exceptionally long life performance.

The plate voltage ratings of tubes are maximum values and are so indicated on the instruction sheets. In the case of the UX-245, the 250-volt rating means just what it implies, i.e., the value beyond which it is unsafe to go from the viewpoint of life performance. Several methods of obtaining this voltage regulation are available but their discussion is beyond the scope of this article. In general, however, the amount of voltage fluctuation caused by line-voltage variation, load variation, and manufacturing variations in the apparatus must be determined or estimated and an average design value should then be decided upon so that under the operating variations to be encountered the voltage ratings of the tube will not be exceeded.

### Electrical Characteristics

TABLE I gives the electrical characteristics of the UX-245 tube under the two operating conditions which will be used most generally. It should be remembered that the values given are average and that individual tubes may vary somewhat from those stated below.

Table I

#### AVERAGE CHARACTERISTICS THE UX-245 TUBE

CHARACTERISTIC	2.5	2.5
Filament volts	2.5	2.5
Plate volts	250	180
Neg. grid volts	50	33
Ampl. Factor	3.5	3.5
Plate Resistance (ohms)	1900	1950
Mutual Conductance (micromhos)	1850	1800
Plate Current (mA.)	32	26

In Fig. 2 a family of plate current-plate voltage curves for various grid-bias voltages is shown. These curves are useful in determining the undistorted power output of the UX-245 tube. The method employed has been referred to in an article which appeared on page 329, March, 1929, RADIO BROADCAST ("A High-Power Output Tube—The 250." by K. S. Weaver) and has also been described, among others, by

Messrs. J. C. Warner and A. V. Loughren in the I.R.E. *Proceedings*, December, 1926, so that this discussion will not be repeated.

The undistorted output obtainable from UX-245 tube is shown in Table II together with similar data on UX-171A, UX-210, and UX-250 tubes.

Table II

OUTPUT OF VARIOUS POWER RADIOTRONS				
Undistorted power output in milliwatts				
PLATE VOLTAGE	UX-171A	UX-210	UX-245	UX-250
180			730	
250		310	1600	900
425		1600		
450				4650

It will be noted that the UX-245 lies between the UX-171A and UX-250 with regard to the undistorted power which it is capable of delivering to a loud speaker, and it has the same output as the UX-210 tube. The advantage of the UX-245 over the UX-210 lies in the fact that the UX-245 delivers the same power as the UX-210 but at about one half the plate voltage required by the latter. This feature is of great importance in connection with set design from the cost standpoint and is one reason for the assured popularity of the new UX-245 tube.

### Operation

AS STATED ABOVE, maximum power output from the UX-245 is obtained when it is operated at normal filament potential, 250 volts (maximum) on the plate, and with a negative grid bias of 50 volts.

Filament voltage recommendations for the UX-245 have already been discussed. However, a few remarks concerning the characteristics of this filament may be of interest. The filament of the UX-245 is of the coated-ribbon type and has high thermal inertia which, in addition to the relatively low filament voltage required, insures "humless" operation on alternating current. This type filament is not affected by the presence of small amounts of residual gas and a slight blue glow in the tube is no indication that the tube is defective or that it is improperly operated. The usual midpoint connection to a re-

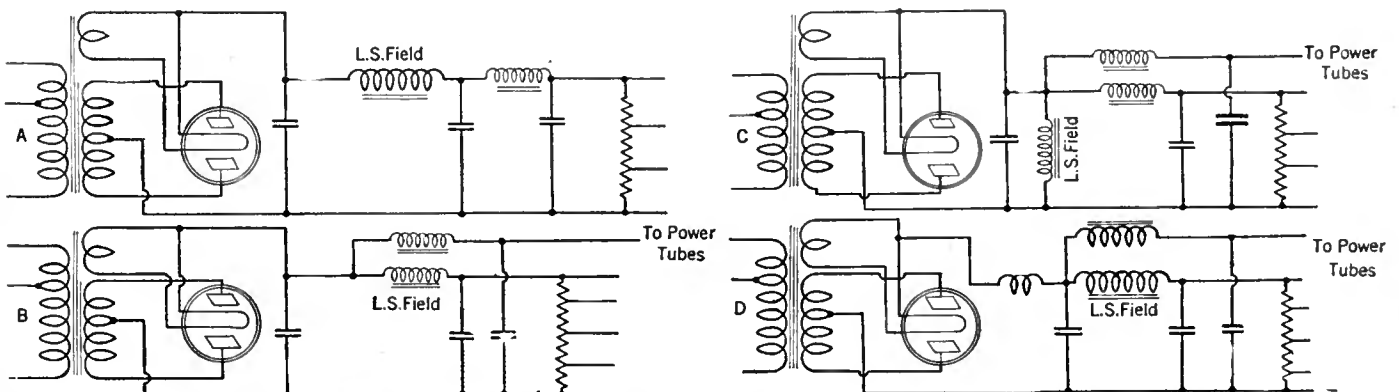

Fig. 1—These diagrams illustrate four methods which may be used for obtaining all potentials required for the operation of a receiver without exceeding the rating of a standard UX-245 full-wave rectifier tube. Each of these power supply systems is designed to supply a receiver of different voltage and current requirements.



sistor placed across the filament terminals or a center-tapped transformer should be used for plate- and grid-circuit return.

The grid swing (50 volts) required to work this tube at its maximum output is easily obtained with sets of present-day sensitivity although when used in "push-pull" circuits the signal input requirement is doubled and this arrangement will call for a set having high over-all gain. When increased power output is desired without increasing the plate voltage supply or grid swing capabilities of the receiver, two UX-245 tubes may be operated in parallel.

The grid-bias voltage for the UX-245 should preferably be obtained by means of a voltage drop across a resistor of proper value placed in the plate-return lead. This is particularly true in resistance-coupled circuits where grid leaks are employed. This "self-biasing" arrangement automatically prevents overloading of the plate and takes care of normal line voltage variation and variations among tubes. When resistance coupling and grid leaks are used it is imperative that the self-biasing connection be used. The grid leak should be made not greater than one megohm so that the grid bias will not be materially reduced in the event that current should flow in the grid circuit.

The plate voltage requirements of the UX-245 are such that the maximum potential (250 volts) may be obtained easily from the type UX-280 rectifier tube. However, the problem of plate voltage supply becomes more involved when two UX-245 tubes are to be supplied in addition to the excitation current for a dynamic loud speaker field and the plate power for the amplifier and detector tubes of the receiver. This condition of use is quite general in this year's receivers and the circuits shown in Fig. 1 will be of interest as they show several methods of obtaining all voltages and currents required without exceeding the rating of the UX-280. This is of particular interest because the use of the UX-280 to supply the plate voltage of a receiver means reduced cost of power pack and reduction in the cost of the receiver.

The rating of UX-280 is as follows:

A.C. volts per anode (r.m.s.) 350 (max.)  
D.C. output current 125 mA. (max.)  
This gives approximately 350 volts at 125 mA. (d.c.)

Because of the many types of dynamic loud speakers in use no values have been assigned to the various components shown in Fig. 1 since the resistance of the loud-

speaker field and a considerable voltage drop at a moderate value of rectified current is permissible in supplying the rest of the set. This would be in case the UX-245, either singly or in push pull, is used as the output tube and either UX-226 or UX-227 tubes are used in the rest of the set.

Circuit c is of advantage where the output power tube requires approximately the full voltage output of the rectifier and only a low voltage drop at a low current is permissible in supplying the rest of the set.

Circuit n<sub>c</sub> shows a series reactor-type filter circuit for use under circuit conditions similar to those of circuit b. In this connection, the series reactor decreases the instantaneous peak current through the rectifier and thus permits that tube to work under more advantageous conditions. However, in order to get the full value of rectified current from this arrangement, the voltage on the tube must be increased beyond the present maximum value of 350 volts, and this is not recommended.

The arrangement of loud speaker field as shown in circuit c may be used also in connection with circuit d.

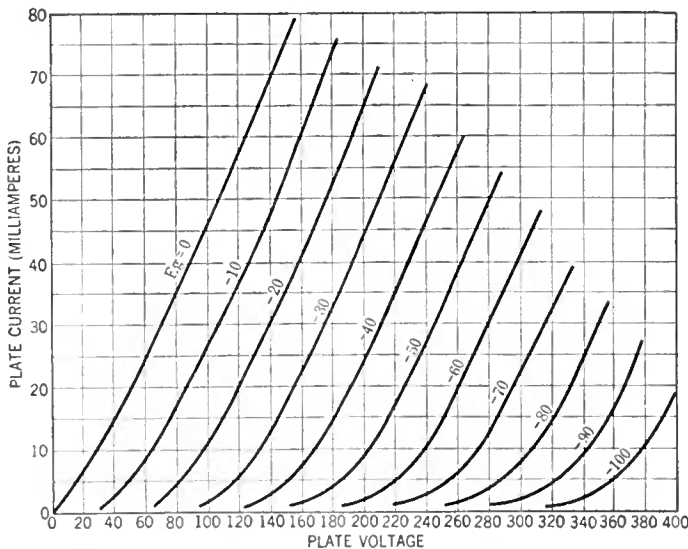

Fig. 2—The undistorted power output available from a UX-245 tube under various operating conditions may be determined easily from the above family of plate current-grid voltage curves.

speaker winding and its power consumption determine their values. The following general discussion of the circuits will serve to illustrate the fundamental practice; the set designer can easily fit into his design the constants and select circuit best adapted to this problem.

#### Four Power Supply Circuits

CIRCUIT A is of use where a considerable voltage drop at a fairly high value of current is permissible; for instance, where the UX-171A, either singly or in push pull, is used as the output tube and UX-226's or UX-227's are used in the rest of the set.

Circuit B is of value where the output power tube requires approximately the

well to point out that high plate voltage does not of itself produce appreciably higher volume. It does permit greater volume without distortion provided sufficient signal is available to swing the grid with maximum efficiency. In sets which do not have sufficient overall gain to swing the grid of the UX-245 to its full value (50 volts) it is good practice to reduce the plate voltage, as conservative operation of this tube, as well as other types, considerably prolongs its life. Under all recommended conditions of use a transformer or choke and output condenser should be employed to couple this tube to the loud speaker in order to prevent the plate current of the UX-245 from flowing through the windings of the loud speaker.

#### Conclusions

IN CONNECTION with a discussion of plate voltage supply for the UX-245 it might



## BOOK REVIEWS



THE RADIO AMATEUR'S HANDBOOK, The American Radio Relay League, Hartford, Conn., 4th Edition, 200 pages, paper covers. Price: \$1.00.

Like its predecessors, the fourth edition of *The Radio Amateur's Handbook* makes no attempt to cover the amateur radio field but confines itself rigidly to telegraphic amateur radio with much stress on message-handling.

The compact first chapter, "What is an Amateur," has been replaced by a longer one on "Amateur Radio." The second chapter remains, as before, a very good introduction to code-learning.

The quite exceptional Chapters 3 and 4 by F. E. Handy have been retained from the original text. They cover the troubled questions of "Fundamentals" and "How Radio Signals are Sent and Received" in a manner that is unusually clear and quite free from the usual semi-correct concessions to brevity.

Chapter 5 on "The Receiver" has

chosen to drop the design information of earlier editions and to substitute an array of "how-to-build-it" discussions. Although they are to be classified as amateur-band covering, only two of the designs include the 160-meter band. The three-tube receiver by Westman is unusually well designed and may well serve as a model.

This reviewer must of necessity approve of Chapter 6 since it is written on the text of his own preachings to the amateur transmitter these past years. By this is meant the proper attention to adjustment of transmitters and the use of circuits with a high ratio of C/LR. The chapter presents an array of constructions which crowds out the very good coil-design information of the earlier editions.

Chapter 7 on "Power Supply, Keying, and Interference Elimination" is sound and adequate. Transformer design, rectifier construction, and battery plate supply are discussed. The classic Dellenbaugh filter information has properly been retained.

Chapter 8 does all for transmitting an-

tennas that one may reasonably expect in 10 pages. The 160-meter band again is somewhat lightly touched upon.

Chapter 9 undertakes the impossible by attacking at once "The Frequency Meter" and "Radio Measurements." The discussion of frequency meters and monitoring oscillators is capable but the designs fail to reach the 160-meter band. "Radio Measurements" cannot be treated in 5 pages without references.

Chapters 10 and 11 relate to the mechanism and manners of the message-handling game which is exhaustively discussed in the 26 pages covered by these chapters.

In recognition of the manifest inadequacy of the space Chapter 12 on "The Experimenter" makes no effort at detail but contents itself with a one-page outline and a reference to some prospective activities.

The appendix contains additional information on coded phrases, distance computations, a few formulas, and a good, though short, bibliography.—R. S. K.

**BUZZERS IN RADIO EXPERIMENTS**

A GREAT DEAL may be learned from a buzzer, although many never think of it in this connection. There are several ways in which a buzzer may be used to generate radio waves. In Fig. 1, a few turns of wire and a large condenser of one or two microfarads are connected across the contact points. When the contacts are separated, the large condenser is charged by the battery, and when they are closed it suddenly discharges through the few turns of wire. On account of the very high ratio of capacity to inductance, this discharge is highly damped and probably results in only two or three oscillations. This sudden impulse, however, starts oscillations in the secondary circuit, which continue for some time as they are but slightly damped, due to the fact that this circuit has plenty of inductance and very little capacity. The wavelength of the resulting radio currents in the secondary circuit will, accordingly, depend on the values of L and C, and may be determined from the equation  $\text{wavelength} = 1884\sqrt{L \times C}$  where L = inductance in microhenries and C = capacity in mfd.

*Another Method*

In Fig. 2 another method of generating radio waves is illustrated. The connections are the same, except that the condenser is smaller and the inductance larger, which reduces the damping effect. High-frequency currents of considerable strength may be generated in this manner by applying several cells to the buzzer, and it has the merit of not seriously affecting other portions of the circuit by inducing stray currents therein.

Probably the most satisfactory circuit for general laboratory work is that shown in Fig. 3. When the contacts are closed, the coil, L, is surrounded by a magnetic field due to the

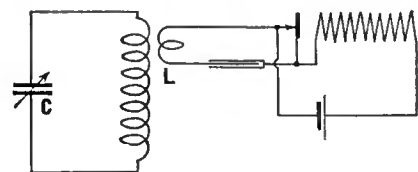

Fig. 1

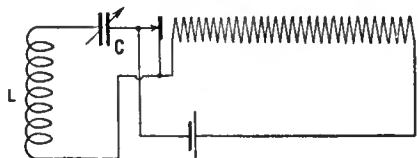

Fig. 2

direct current flowing therein. When the contacts are open, this field collapses rapidly and thereby induces a voltage in the coil, which charges the condenser, C. When the magnetic field has ceased to generate further voltage, the condenser discharges through the coil, and so on until the resistance of the circuit completely dampens the oscillations. At the next movement of the vibrator, the process is repeated.

The buzzer simply functions as an electrical hammer that applies a blow to an electrical hammer at regular intervals, the weight continuing to oscillate at its own natural period between the blows. If the value of L and C were such as to have a wavelength of 300 meters, and the buzzer had a pitch of 1000 per second, there would be time for 1000 radio oscillations for each oscillation of the buzzer.

By means of the buzzer and the inductance and capacity standards referred to in "Home-Study Sheets," Nos. 20 and 24, we are now in a position to set up a radio current of any desired wavelength, but before undertaking this it is desirable to consider the mechanical features of buzzers, and also to provide some additional measuring apparatus.

*Unsatisfactory Types*

There are several high-pitched buzzers on the market that will answer very well in this connection. These are made specially for radio work, such as code instruction and testing crystals. The ordinary house buzzer is of too low a pitch to be satisfactory. Also, the kind that is connected up as indicated in Fig. 4 should be avoided, for the reason that when the contacts are open there is still a fairly large capacity across them due to the fact that one of the binding posts is in contact with the case and the magnet cores, while the other is connected to the surrounding coils. Sometimes buzzers are provided with a resistor across the

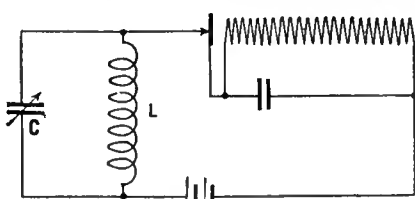

Fig. 3

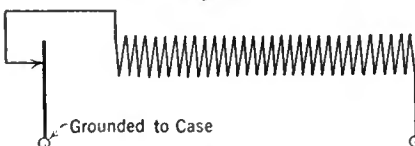

Fig. 4

contacts to prevent sparking. Such a resistor would have to be removed to make the buzzer suitable for radio work.

*Making a Buzzer*

It is quite surprising to learn what a satisfactory radio current may be generated by a single dry-cell battery and a very small buzzer. Suitable ones of high pitch are not very difficult to make, and they lend themselves admirably to the construction of bridges, wavemeters, etc. Fig. 5 illustrates the general plan of construction, and to what extent the dimensions may be reduced. Buzzers of this type may be made that will vibrate as high as 5000 times a second. The magnet core is simply a piece of soft iron wire about an eighth of an inch in diameter or a bundle of soft iron wire (stove-pipe wire will do) of the same size. In making the hair-pin turn, care will be necessary to keep the two legs straight and parallel. On a straight piece of the same material a thin paper tube is formed by wrapping it with a strip of paper to which glue has been applied. When the tube has hardened, two suitable lengths are cut, and each is wound with number 32 or 34 enameled wire. Shellac must be applied during the winding, and if considerable tension is used in placing the turns, each successive layer may be stepped back half a space, as indicated in the drawing. In this manner the necessity of making two very small bobbins is obviated. When the shellac has hardened thoroughly, the coils are then pushed onto the iron core and the connection between is soldered.

The vibrator is a one-eighth inch strip of the thinnest commercial tin, from which the tin coating has been polished off. While this may be supported by soldering it to one of the magnet poles, it is preferable to provide a separate brass block. This should be heated in a clean flame just enough to permit the tinning of the space where the vibrator is to be applied. The latter may then be coated with flux, and steadily held in position until cool. In this way there should be no danger of drawing the temper of the vibrator.

Considerable care will be necessary in providing the contacts. A small piece of platinum wire should be procured from the jeweler, say about an inch of No. 30 gauge. Hammer out one end to form a little spring, not over three-sixteenths of an inch long. Using a piece of heavy tinned copper wire as a soldering iron, attach the platinum to the vibrator with the least amount of solder possible. When the contact screw has been provided, a short length of the platinum wire is soldered on the end, care being taken to remove all surplus solder. The base should be cut from a piece of panel material, to which the magnet is secured by

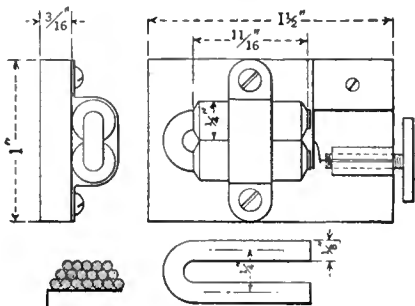

Fig. 5

means of a thin brass yoke held down by two 4-36 screws.

That such a buzzer is working properly cannot be determined by its sound, although it is essential that the note be clear, musical, and steady. It is only when the resulting radio currents are detected with a crystal and are listened to in a telephone receiver that the final result can be ascertained. Not infrequently the strength and quality of the note can be improved materially by placing a rather large fixed condenser across the magnet coils.

*Determining Frequency*

There is a simple way of determining with a fair degree of accuracy the frequency of high-pitched buzzers. It is also interesting and instructive from the standpoint of radio. In Fig. 6, L is a 1500-turn duo-lateral or honey-comb coil, the inductance and distributed capacity of which we will accept from the manufacturer's statement. L is 8 or 10 turns of wire wound on a wooden core and slipped inside of the large coil. L C is a calibrated condenser reading up to 0.001 mfd. and to one side is connected a crystal detector with a telephone receiver across it. If the buzzer is now started, the sound should be heard clearly in the receiver, and, as the condenser C is varied, the character and intensity of the note will pass through a series of changes, alternately becoming clear and loud, and then indistinct and confused. The points at which these changes

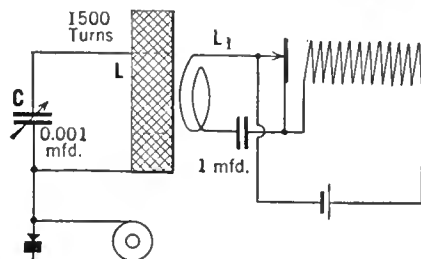

Fig. 6

occur will be found close together at the lower dial readings and further apart toward the upper end of the scale.

In the circuit with which we have been experimenting each impulse of the buzzer starts a series of oscillations in the circuit L C, and the frequency of these oscillations is given by the formula

$$f = \frac{159200}{\sqrt{LC}}$$

When the note in the telephone receiver is strong and clear, the frequency of the radio oscillations is an exact multiple of the frequency of the buzzer. To illustrate by figures, assume that at 100 on the condenser dial, C indicates a capacity of 0.001 mfd., and that the lower readings are strictly proportional, as would be the case if the condenser capacity curve were truly a straight line. Let it be further assumed that the coil, L, has an inductance of 175,000 microhenries. With these values a critical point might be noted at, say, number 23.1 on the condenser dial, a second one at 31.2, a third one at 41.1, and so on. The corresponding capacities would be 0.000231, 0.000315, and 0.000411 mfd. Multiplying these by 175,000 we find the value of LC, and the corresponding frequencies may then be found from the formula or by consulting the wavelength and frequency table presented in "Home-Study Sheet" No. 19 (April RADIO BROADCAST). In the present case, these will be found to be frequencies of approximately 12,000, 14,000, and 16,000 cycles per second. The uniform difference of 2000 is the frequency of the buzzer.

In actual practice, depending on the values involved, five or ten critical points may be identified, in which case it is necessary to divide only the difference between the first and last radio frequencies by the number of steps involved, which will, of course, be one less than the number of readings taken. It is also necessary, if accuracy is desired, to add to the capacity of the condenser at each reading the distributed capacity of the coil L, which will be of the order of .00003 mfd.

When a radio-frequency galvanometer, to be described later, has been made, it may be inserted directly in the oscillatory circuit LC, and the crystal and receiver may be dispensed with. The experiment is more striking when carried out in this manner, as the galvanometer shows a marked increase in deflection whenever a critical point is passed.

COUPLED CIRCUITS

"WHEN TWO circuits are placed or inter-connected so that energy may be transferred from one to the other they are said to be coupled." Morecroft, *Principles of Radio Communication*, p. 95, Second Edition

Kind of Coupling

Circuits may be coupled together by means of resistance, capacity, or inductance. Thus, in Fig. 1, the plate circuits of two radio-frequency amplifier tubes are coupled. These

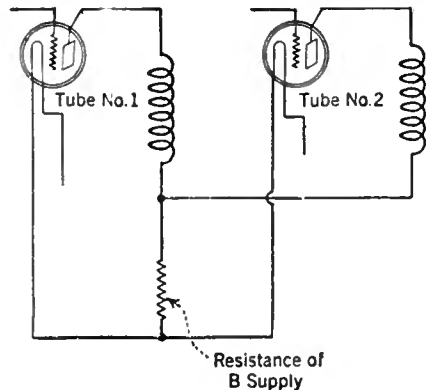

Fig. 1

tubes get plate current through some device that has an internal resistance, the voltage divider of power supply equipment, for example. Now the plate currents of tube No. 1 and tube No. 2 flow through this resistor which is common to both circuits. The voltage that is across this resistor due to the plate current of tube No. 2 is impressed in the plate circuit of tube No. 1. This is our definition of coupling; and so tubes Nos. 1 and 2 are coupled together. This is resistance coupling.

The classic example of undesired coupling due to capacity is that existing within a tube due to grid-plate capacity. Thus, in Fig. 2 is a representation of a tube circuit in which  $R_i$  is the input circuit, the voltage across which is amplified by the tube to reappear in the plate circuit as  $\mu E_g$ .  $R_o$  is the output resistance which is in series with the plate resistance and  $\mu E_g$ , and  $C_{gp}$  is the grid-plate capacity which couples  $R_o$  to  $R_i$ . If the coupling due to  $C_{gp}$  becomes great enough that a voltage is produced across  $R_i$  equal to that across  $R_o$  divided by the  $\mu$  of the tube, oscillations occur.

Of course, the most familiar example of coupling is that due the mutual inductance between two coils—a transformer as in Fig. 3. The bracket, marked M, indicates that mutual inductance exists between P and S.

Inductance formulas and laboratory experiments demonstrate that the inductance of a coil varies as the square of the number of turns, so that if one doubles the number of turns on a given coil he will have four times the inductance. Now let us suppose we have two identical coils,  $L_1$  and  $L_2$ , as in Fig. 4. If they are connected in series so that the turns are in the same direction the same effect will be produced as if twice as many turns had been wound on a single coil. The inductance will be four times the inductance of a single coil. Now if one of the coils is reversed so that its turns are in the opposite direction to those in the other coil, the inductance will be zero. Actually, however, the inductance will be neither four times that of a single coil in one case nor zero in the other because it is not possible to get perfect coupling between coils.

In the "series-aiding" case where the inductance is increased by adding two coils together, the measured inductance will be made up of the inductance of coil 1, plus the inductance of coil 2, plus the mutual inductance due to the lines of force from coil 1 that go through coil 2,

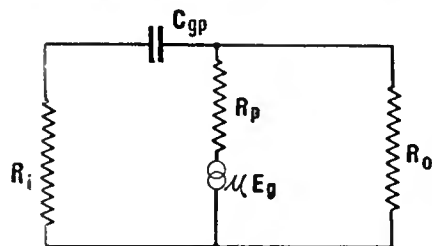

Fig. 2

and plus the mutual inductance due to the lines of force from coil 2 that go through coil 1. Thus:

$$\begin{aligned} \text{Series Aiding, } L_a &= L_1 + L_2 + 2M \\ \text{Series Opposing, } L_o &= L_1 + L_2 - 2M \end{aligned}$$

and if the coupling between coils is perfect and  $L_1$  is equal to  $L_2$ ,  $L_a$  will equal  $4L_1$ . If the coupling is less than perfect, and in air-core coils it is always much less than perfect, the total inductance will be less than  $L_o$  in the series-aiding case and greater than zero in the series-opposing case.

Measuring Mutual Inductance

Let us suppose we have a transformer, as in Fig. 3, and we want to know how much mutual inductance exists between the two coils, P and S. How shall we measure it? Let us connect the two coils in a series-aiding circuit and measure the inductance  $L_a$ . Then connect them in a series-opposing circuit and measure the inductance  $L_o$ . Then we have two equations given above and if they are subtracted, we shall have  $4M = L_a - L_o$ . Of course, if we already know  $L_1$  and  $L_2$  we can calculate M from either of the equations above, but when measuring inductance it is just as simple to measure both the series-aiding and series-opposing cases.

Example 1: In the Laboratory it was desirable to know the mutual inductance between the primary and the secondary of an interstage r.f. transformer. The primary and secondary inductances measured 10 and 160 microhenries, respectively, and the total series-aiding inductance was 210 microhenries. The series-opposing inductance was 130 microhenries. What was the mutual?

$$\begin{aligned} \text{Solution:} \\ L_a &= 160 + 10 + 2M = 210 \\ L_o &= 160 + 10 - 2M = 130 \\ \text{Subtracting } L_a - L_o &= 0 + 0 + 4M = 80 \\ M &= 20 \end{aligned}$$

and thus the mutual inductance was 20 microhenries.

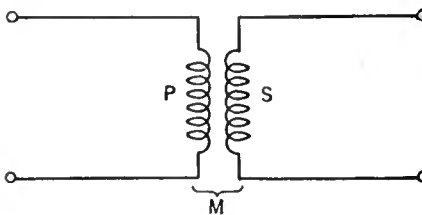

Fig. 3

Coefficient of Coupling

It is desirable to have some expression which tells us how much two circuits are coupled; that is, the expressions "loosely" or "closely" coupled are only relative and really tell us nothing at all about what the mutual inductance is. What would be considered as close coupling in an air-core transformer would be very loose in an iron-core transformer.

The expression "coefficient of coupling" is such a term. It is

$$K = \frac{M}{\sqrt{L_1 L_2}}$$

Perfect coupling gives a coefficient of 1; it is sometimes called "unity coupling." A closely coupled circuit at radio frequencies may give a coupling as high as 70 per cent. (a coefficient of 0.7), but this is higher than obtained in most cases. K can never be greater than 1.

Example 2: In Example 1 what is the coefficient of coupling between primary and secondary?

$$\begin{aligned} \text{Solution:} \\ K &= \frac{20}{\sqrt{160 \times 10}} = \frac{20}{\sqrt{1600}} = \frac{20}{40} = 0.5; \text{ or the} \\ &\text{coupling is 50 per cent.} \end{aligned}$$

Fig. 5, taken from Morecroft, p. 33, explains how the coefficient of coupling must be calculated.

When circuits are coupled by a transformer, or by any other kind of coupling, current flowing in one circuit induces a voltage in the other. This voltage forces current to flow through the load in the secondary circuit and thus uses power. The secondary voltage is given by

$$E_s = I_p \times M \phi$$

where  $I_p$  is the current in the primary.

Problem 1: If the a.c. current in the primary of the radio-frequency transformer in Example 1 is one microampere at 1000 kc. what is the secondary voltage? Answer 125.6 microvolts.

The case of the transformer with tuned secondary of the type used in the great majority of modern radio receivers was considered in "Home-Study Sheet" No. 22 (May, 1929, RADIO BROADCAST). Now what happens if both primary and secondary are tuned?

Such a transformer with both primary and secondary tuned to the same frequency

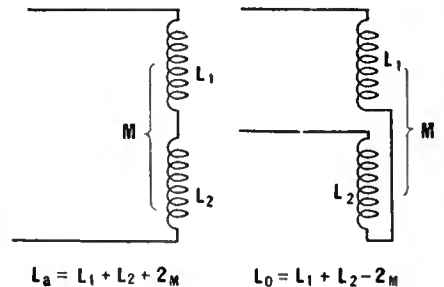

$$L_a = L_1 + L_2 + 2M \quad L_o = L_1 + L_2 - 2M$$

Fig. 4

may be applied to the antenna circuit as a sort of pre-selecting circuit or as a coupling means between tubes. As a pre-selector, the system is used, with certain modifications, in the Sparton receivers as well as the Continental Radio Corporation's "Sky Raider," both built under Technidyne patents. Between stages in an r.f. amplifier the doubly-tuned transformer is used in the "Hi-Q 29" kit receiver, in the Radiola 60 intermediate-frequency amplifier, and in the Freshman Mystery receiver.

If two circuits are tuned independently to the same frequency and then coupled to each other, there will be two frequencies to which the circuit will tune and neither of these frequencies will be the original frequency to which the two circuits were tuned individually. If the coupling is weak, the two frequencies will be close together and give a flat-topped response curve; if the coupling is close the two frequencies will be far apart and give a response curve looking like two peaks widely separated with a deep valley between them.

The two new frequencies to which the circuit will respond are given by

$$\begin{aligned} f_1 &= f_0 \sqrt{1+K} \\ f_2 &= f_0 \sqrt{1-K} \end{aligned}$$

in which  $f_0$  is the frequency to which the individual circuits are independently tuned and K is the coefficient of coupling.

Example 3: If the coupling between two such circuits is 10 per cent. ( $k = 0.1$ ), the two new frequencies will be respectively  $f_0 \times 1.05$  and  $f_0 \times 0.95$  and so, if the frequency  $f_0$  is 1000 kc. the two frequencies will be 1050 and 950 kc., respectively.

If the two circuits are identical, having the same capacity, inductance, and resistance, and are attached to similar circuits, the two peaks will have the same height.

Problem 2: Assume a fixed degree of coupling, say 1.0 per cent., and calculate the peaks of the two frequencies as  $f_0$  is, respectively, 600, 1000, and 1500 kc. As a result of these calculations do you see any reason why the system may fail in radio receivers?

Problem 3: Assume a fixed value of  $f_0$ , say 1000 kc., and various values of coupling. Calculate the frequencies of the two peaks as the coupling varies through small values, say 1 per cent. to 10 per cent.

Problem 4: Suppose the frequency  $f_0$  is 100 kc., as in a super-heterodyne, and calculate the response frequencies as the coefficient of coupling varies from 0.1 to 0.9.

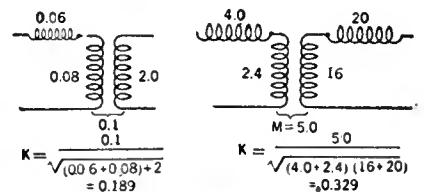

Fig. 5

# How the Engineers Solved Their Problem

## DESIGN DETAILS OF THE FADA SET

By E. A. UEHLING

Engineering Department, F. A. D. Andrea, Inc.

AMONG THE most important of the recent contributions to radio are the screen-grid tube and the band-pass filter. The first of these permits a flexibility in circuit design that has been possible with no other tube. It makes possible the separation of the function of station selection from the function of amplification.

Separating the functions of amplification and selection is essential if signal selection is to be accomplished in any other way than by the method of single-resonance circuits in cascade, with its attendant frequency distortion. There is another advantage in this separation of functions. If the desired signal is not entirely separated from the undesired signals before being passed on to the first amplifier tube, the latter may modulate the former, because of the non-linear characteristic of the amplifier tube. This modulation is especially noticeable in the neighborhood of a strong broadcast station, which, as a consequence, may be heard over a large portion of the broadcast range whenever another carrier is tuned-in, the frequency of which may be as much as 40 or 50 kilocycles from the fundamental frequency or harmonic frequency of the interfering station.

For the reason described above, if for no other, it is important to precede the amplification in the receiver by adequate signal selection. These functions can be separated by using a band-pass filter to precede the first amplifier tube with the result that very good selectivity can be combined with very slight frequency distortion in the radio-frequency part of the receiver.

The receiver described in this article has a band-pass station selector unit of pre-assigned characteristics followed by two stages of radio-frequency amplification, a detector of the plate-rectification type, and an audio amplifier having in the output stage two 245 tubes in push pull.

### Requirements of a Good Set

A GOOD RECEIVER should have a radio-frequency voltage amplification of about 5000. If the amplification is considerably less

than this value the receiver may not be capable of distance reception and a detector of the plate-rectification type is not entirely satisfactory. If the amplification is greater than this value, the receiver will, in general, amplify signals that are below the noise level, and it may be unsuited for general use in localities in which there are powerful broadcasting stations in this immediate vicinity.

Before considering the methods by which this value of amplification is to be obtained, let us consider the single stage. The amplification per stage with a screen-grid tube is

$$g = G_m R_L$$

where  $G_m$  is the mutual conductance of the tube and  $R_L$  is the load resistance.

This relationship holds for the 224-type tube because all values of  $R_L$  that can be attained in practice are small compared with  $r_p$ .

If  $R$  is 10 ohms at 535 meters,  $L$  is 200 microhenries, and  $C$  is 400 micromicrofarads,  $R_L$  is equal to approximately 50,000 ohms. Since the mutual conductance of the 224-type tube is about 1000 micromhos, the total amplification that can be obtained with one stage is equal to the product of  $1000 \times 10^{-6}$  and 50,000 or 50. Two stages will then give an amplification of about 2500, and, with a gain in the antenna and filter circuit of only 2 or 3, we have acquired the required amplification of 5000.

### Impedance Coupling

WHEN THE amplification problem was first considered, all methods were subjected to theory and experiment. The final choice of tuned impedance coupling is based on the results of actual experi-

ment, but these results check the theory so well that a description of the advantages of impedance coupling can be illustrated very adequately by considering the actual physical problem involved. Because of the very high plate resistance of the screen-grid tube, the coupling between plate and grid circuits must be very close in order to satisfy the conditions of optimum gain.

As a matter of fact, this condition can be realized only partially in practice. In order to realize this condition with transformer coupling the primary inductance must be very high, that is, equal to or greater than the secondary inductance, and the coefficient of coupling must be as near unity as possible. In general, this design means a transformer of rather high dielectric losses and high mutual capacity. There are other considerations of even greater importance. If the optimum resonance relation is as nearly satisfied with transformer coupling as it would be with impedance coupling, the primary will require a greater number of turns than the secondary even though the coefficient of coupling be very near unity. The effect of the plate resistance on the selectivity of the circuit then begins to assume proportions no longer negligible. The effective resistance due to the internal plate resistance added to the secondary circuit may amount, at 200 meters, to 10 ohms or more. The actual amplification that can be obtained with transformer coupling is approximately equal to that which can be obtained with impedance coupling under the same conditions. The mutual inductance, of course, must be very high, and practical difficulties are encountered that are not met when impedance coupling is used. That the amplification with impedance and transformer coupling is about equal becomes evident when the comparative values of  $L/R_2C$  and  $\omega^2 M^2/R^2$ , the load resistance for tuned impedance and transformer coupling, respectively, are considered. The value of the first of these two quantities in a given case we have found to be equal to 50,000 ohms at 535 meters. The value of the second of these two quantities at the

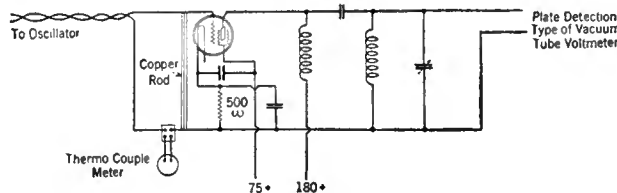

Fig. 1

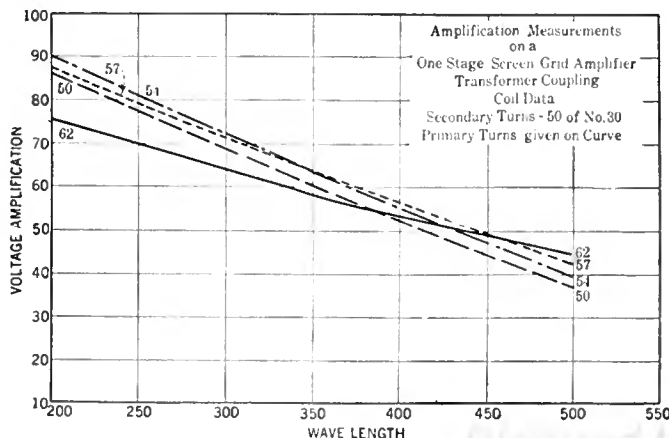

Fig. 2

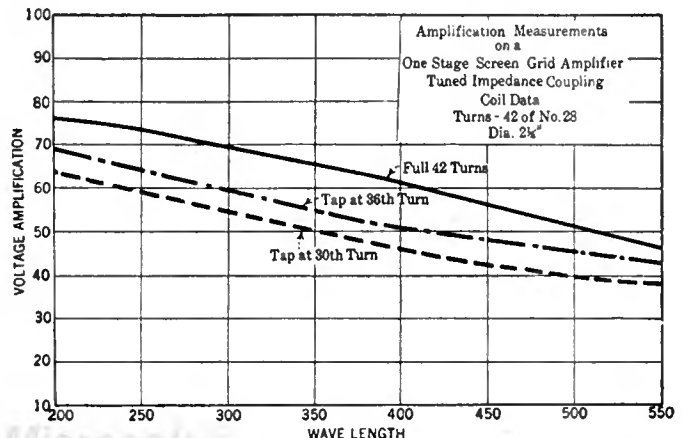

Fig. 3



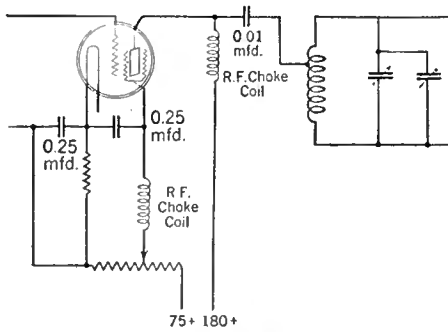

Fig. 4

same wavelength and for a transformer of mutual inductance equal to  $200 \times 10^{-6}$  henries is 51,000 ohms.

*Simplified Design*

Thus, the amplification problem has been considered without resort to the more complicated amplification formulas that must be used for other types of tubes. The very high plate resistance of the screen-grid tube makes for simplification in design as well as simplification in mathematical circuit considerations.

In the original experimental work on this receiver, it was necessary to measure the amplification under actual operating conditions in order to check the theoretical results. At that time there was no calibrated oscillator with a calibrated signal output of a wide range of values available and a method of making these measurements had to be developed.

Because of the high amplification of the screen-grid tube the required input voltage had to be so small as to offer considerable difficulty in measurement. Several methods of measuring these small voltages were tried with only partial satisfaction. Finally it was decided to use a method that did not require the measurement of the input voltage. A relatively large signal current that can be measured with a sensitive thermo-couple was made to flow through a definite length of straight copper rod of negligible resistance. The inductance of this short, straight rod of copper could be calculated and thus the reactive voltage drop was known. The circuit used in making of these measurements is illustrated in Fig. 1. The copper rod is 29.2 cm. in length and 0.14 cm. in diameter with a self inductance of 0.341 microhenries at 550 kc. and 0.339 microhenries at 1500 kc.

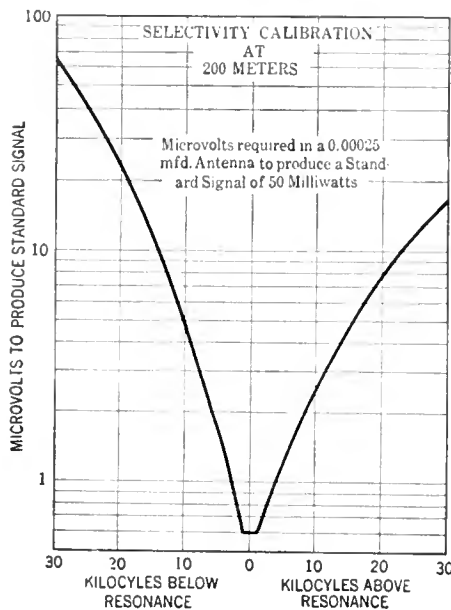

Fig. 7

Its impedance at 515 meters is, therefore, 1.179 ohms and at 200 meters it is 3.197 ohms. With a current of 2 milliamperes flowing through it, the reactive voltage drop is 2.358 millivolts at 545 meters and 6.394 millivolts at 200 meters. This method is not absolutely accurate because of end effects and the mutual reactance between the rod and the rest of the circuit and ground. But with a little care in arrangement of the rod itself, and the lead wires to the rod, errors arising from this source can be reduced to a very small value. Actual amplification measurements as obtained with this apparatus for a few of the more interesting conditions are shown in the graphs (Figs. 2 and 3) on the preceding page.

*Amplification per Stage*

Nothing has been said up to the present regarding the conditions that affect the actual value of amplification per stage. Regardless of the kind of coupling used, the amplification is inversely proportional to the radio-frequency resistance of the resonance circuit. Low-loss coils of large size wire and good shape factor are very important, and this implies further that the coil shielding itself must be as

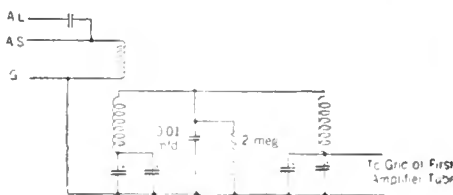

Fig. 5

large as it is practical to make it. As a second condition for good amplification, the ratio of L to C should be large. Making this ratio large also improves the selectivity of the circuit.

There is, however, a very practical upper limit to the value of the ratio of L to C. The larger L is made, the smaller will be the maximum capacity of C necessary to reach the upper limit of the broadcast range. There are, however, fixed capacities in the circuit such as the plate-filament capacity of the tube, and capacity of the compensating condenser, and the minimum capacity of the tuning condenser itself, the total value of which fixes the upper limit of L.

Attention may be called to the amplification curves of Figs. 2 and 3 which were made by using the circuit of Fig. 4. It will be seen at once there is a discrepancy between the calculated amplification for impedance coupling and the measured values. It is obvious that the results that can be obtained with impedance coupling are largely dependent on the characteristic of the r.f. choke coil supplying the tube plate voltage. The measurements on impedance coupling already referred to were made before the r.f. choke coil used in this receiver was designed. This choke coil has three sections. It has an impedance at 500 meters of 70,000 ohms which increases gradually as the frequency increases to a value of about 500,000 ohms at 200 meters. The resonance point of this choke coil falls at approximately 200 meters, or a little higher.

Thus far we have considered only the amplification per stage and find that the amplification of two stages on the basis of the results already discussed, is sufficient and all that is desirable in a good receiver. There will, of course, be some regeneration though none has been purposely introduced, and the actual shape of the amplification curve may be modified to some

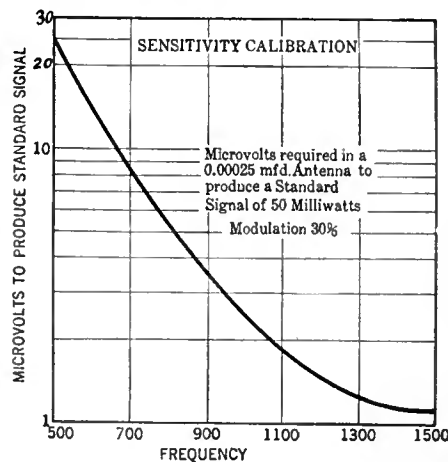

Fig. 6

extent in the completed receiver by the antenna coupling method used and other factors. Actual overall amplification measurements which will be discussed later indicate, however, that these effects are small and need not be considered further.

*Detection System*

Having obtained an overall radio-frequency amplification of approximately 5000, we are at liberty to use plate rectification (C bias) in the detector. It is less efficient than the grid rectification so commonly used up to the present time, but this efficiency is not necessary with the amplification available. It is capable of more faithful reproduction, or, to put it more accurately, the tendency to frequency distortion found in grid circuit rectification with the values of grid leak and condenser generally employed, does not exist in anode detection. A second advantage of plate rectification is the greater audio output power of the anode detector. Detector overloading has been one of the most serious limitations of radio receivers in the past. With the use of plate detection, and the high radio-frequency amplification that makes it possible, a serious defect of past receivers has been eliminated.

As already stated, there is a signal selector of band-pass characteristics preceding the first radio-frequency amplifier tube. There are at the present time many types of band-pass filters, and such filters have been used for a long time in tele-

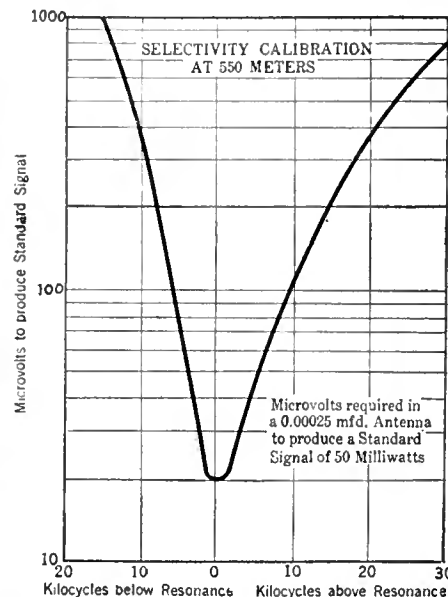

Fig. 8

phone work. But a filter that will meet the requirements for one case may not be at all suitable for another. As a result, it has not been easy to supply a filter of band-pass characteristics for broadcast use.

All filters that are simple enough mechanically and electrically for radio receiver use have the unfortunate characteristic of varying band width for different frequencies in the broadcast range. In most filters already used the band of frequencies transmitted is narrow at the high wavelengths and very wide at the short wavelengths. This condition is an unfortunate one, not only because the width of band varies with wavelength but also because it varies in the way it does. The selectivity at the short wavelengths is usually not very good even in the best receivers because of the increased resistance of the radio-frequency circuits at the higher frequencies. It is obvious that if the width of the band transmitted by a band-pass filter increases as the wavelength decreases, the tendency toward broad tuning at the shorter wavelengths will be even more pronounced.

*The Band-Pass Circuit*

A SIMPLIFIED circuit of a band-pass filter having more desirable characteristics is shown in Fig. 5. It will be noted first of all that no magnetic coupling exists between the two circuits. There are two principle advantages of coupling these circuits as shown and these advantages will be described as follows: We are interested in the width of the transmission band which depends on the value of the quantity  $\sqrt{R_1/R_2} (M^2 - R_1R_2)$  where  $R_1$  and  $R_2$  are the circuit resistances and  $M^2$  is the absolute value of square of the coupling impedance. It will be seen that this coupling impedance should vary as the product  $R_1R_2$  varies with frequency, so that the quantity  $(M^2 - R_1R_2)$  is as nearly constant with frequency as it can be made. When the coupling between the circuits is magnetic the variation of the mutual reactance is numerically equal to  $L$  and when the coupling between the circuits is capacitive, the variation of the mutual reactance with frequency is numerically equal to  $1/\omega^2C$ .

Suppose we decide on 4 per cent. coupling as the value which gives the desired width of band at the longest wavelengths. With 230-microhenry tuning coils the mutual inductance will then have to be 9.6 microhenries and the variation of the mutual reactance with frequency as expressed by

the first formula above will be  $9.6 \times 10^{-6}$ . Now, if the coupling between the circuits is capacitive, and a coupling of 4 per cent. is again chosen, the coupling capacity will be about 10,000 micromicrofarads, and at 550 meters the variation of reactance with frequency as determined by the author's mathematical calculations will be  $10 \times 10^{-6}$ . For either type of coupling the variation of reactance with frequency at 550 meters when the coupling percentage is adjusted for the same width of band is the same. But in the case of magnetic coupling this variation is constant regardless of frequency, and in the case of the capacity coupling the variation in reactance with change in frequency decreases

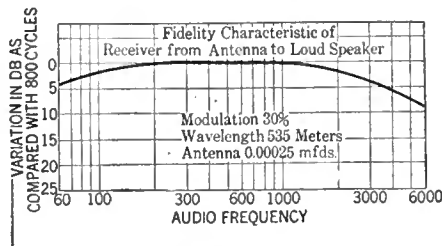

Fig. 9

as the frequency increases. Thus we find at 200 meters the variation of reactance with frequency is equal to only  $1 \times 10^{-6}$  as compared with  $10 \times 10^{-6}$  at the same frequency for magnetic coupling. So in the broadcast range capacity coupling gives a more nearly uniform width of band than magnetic coupling, provided the width of the band is made the same for both types of coupling at 550 meters. That is, the actual arithmetic variation in band width is less for capacity coupling than for inductive coupling.

The second of the two principle advantages of this type of band-pass filter is that whatever variation in band width there is, is in the most desirable direction as already stated. As the receiver tuning dial is turned to the shorter wavelengths, the coupling percentage is reduced constantly. This reduction in percentage of coupling is slightly more than is required to give constant width of band with the result that there is a slight decrease in band width at the lower wavelengths.

The use of a band-pass filter is not without some loss in voltage amplification as compared with other methods of signal selection. But in this receiver with its two stages of screen-grid amplification, the full voltage step-up usually obtained in

the antenna circuit is not only unnecessary but actually undesirable. In another part of this paper it was stated that there is a voltage gain in the antenna circuit of this receiver through the band-pass filter of about 2 at 550 kilocycles and about 4 or 5 at 1500 kilocycles.

*Overall Performance*

THE OVERALL performance of the receiver is adequately described by four sets of measurements made on the receiver with the aid of a calibrated signal generator. These measurements are illustrated in Figs. 6, 7, 8, and 9. In obtaining the data for all of the curves, the input to the dummy antenna of the receiver was adjusted until a standard signal of 50 millivolts in a resistance connected across the secondary of the output transformer was obtained. In all of these measurements an 0.00025-mfd. antenna was used. In Figs. 7 and 8 the data obtained in making a set of selectivity measurements at high and low wavelengths are plotted as a function of kilocycles below and above resonance. In Fig. 9 we have an overall fidelity curve of the receiver. The absence of sideband cutting is apparent, yet the selectivity measurements just described show that the receiver is unusually selective at both high and low wavelengths. In obtaining the fidelity curve the modulation was held constant at 30 per cent. as the audio frequency was varied. As before, the input was adjusted for a standard signal in the output, and the ratio of the input at various frequencies to that required at 800 cycles was taken as the basis for obtaining the variation in transmission units of the overall radio-frequency characteristic of the receiver.

A circuit diagram of the radio-frequency circuits of the new Fada-35 receiver which embodies the features that have been described is shown in Fig. 10. Provision is made for connecting the output of a phonograph reproducer or a condenser microphone in the detector grid circuit. This provision makes the receiver suitable for certain kinds of public-address work. The output is designed to match a 3-ohm voice coil of a dynamic loud speaker.

The receiver can be used with a short antenna in most localities with good results. In apartment buildings and other localities where an antenna is not available, the link switch can be closed connecting the receiver input to one side of the power line. With this connection no external antenna of any kind is required.

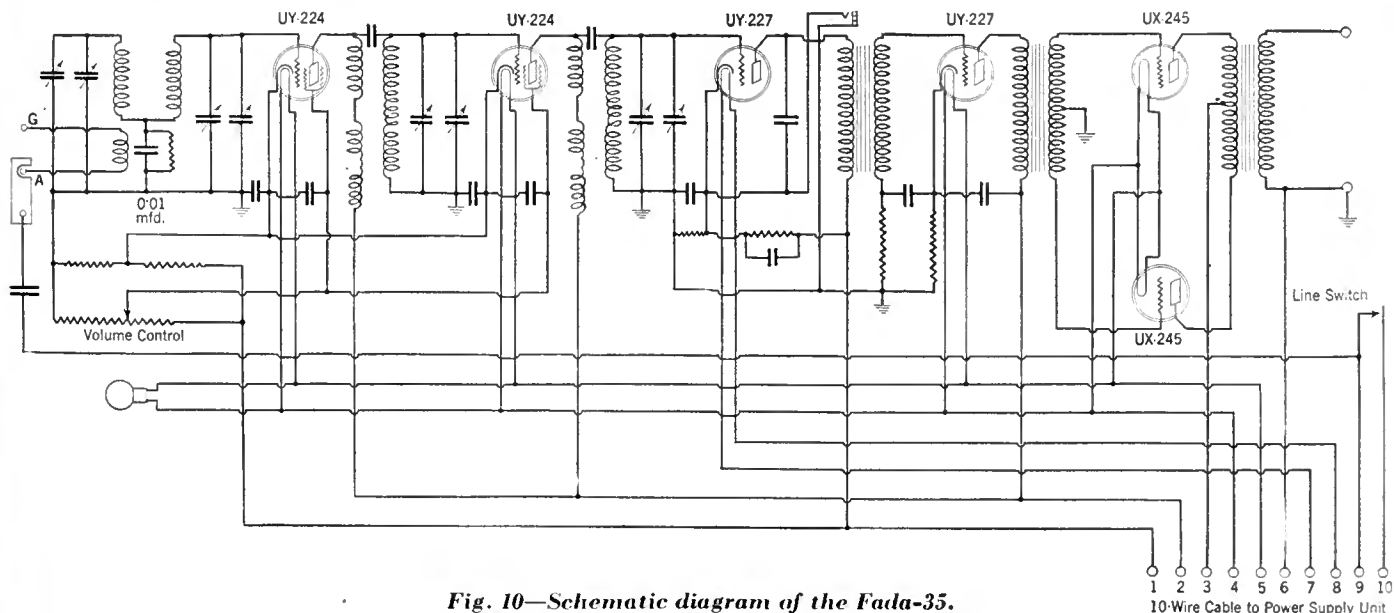
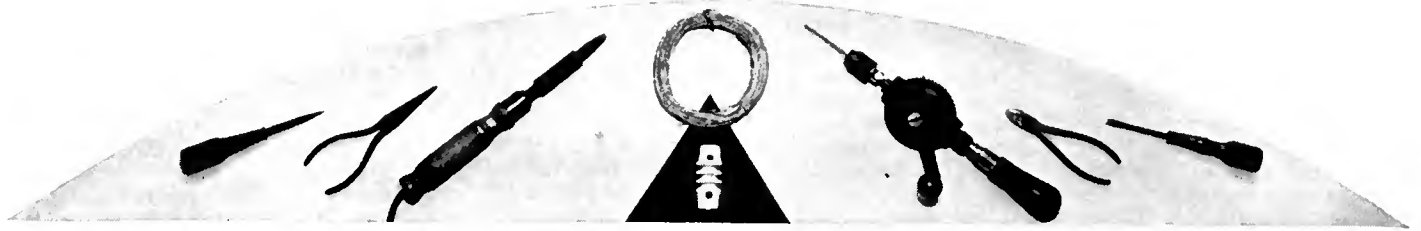

Fig. 10—Schematic diagram of the Fada-35.



## THE SERVICEMAN'S CORNER

### Hints on Majestic Sets

**T**HE MAJESTIC receiver is one of the season's most popular sets, and the following points on their servicing will be of assistance to many of our professional readers.

*Short by-pass condensers:* ART HUGHES, of Newark, N. J., writes: "I have been servicing Majestic Sets since they first made their appearance.

"The troubles with Majestics are very few and simple, but for a man who does not understand the set they may appear many and serious.

"When he goes to answer a service call and finds, through his Weston or Jewell, he gets only 50 volts on his r.f. and first a.f. and about 10 volts on his detector plate, first thing he blames is the power pack, takes it out, and puts same on bench for test. He is all wrong, the pack is ok., the trouble is in the chassis.

"The trouble invariably is a shorted twin by-pass condenser in the r.f. B-plus lead located near the volume control. Do not take chassis out, just take a 100-volt a.c. pair, put one wire on the chassis and touch the other on the outside terminals of the loud speaker connections. Before doing this remove the ground wire from the set, also the loud speaker from the terminal strip.

"The result of applying the a.c. is simply this: the short is cleared, due to the heavy current burning the condenser wide enough so that the comparatively low current and voltage used by the set will not jump the punctured section.

"To test a power pack on the bench you have to connect either the loud speaker field or a suitable choke across the 96-volt and 220-volt terminals on the connection block in power pack."

*Poor connection through eyelets:* "This trouble was encountered in a Majestic set. The set would play satisfactorily and then suddenly cut out. As usual the set would play all right when the serviceman arrived. Continuity test showed all connections apparently ok. It was found that upon pressing the speaker and speaker-field-coil connection strip that the machine would cut out. This strip was removed and to all appearances seemed to be in good condition. However, upon reconnecting, it acted the same as before. The lugs for the connections on this strip are held by eyelets punched through the bakelite. These eyelets are not soldered to the lugs so they form a possible chance for a poor connection. After the lugs were soldered to the eyelets, the receiver performed satisfactorily. This trouble was not due to failure to tighten the binding posts as might be suspected."

H. WEIMAN, Appleton, Wis.

*Adjusting gang condensers:* ROBERT FREEMAN, dealer in Majestic and Ever-ready receivers, of Adel, Iowa, helps the cause along as follows:

"In servicing Majestic radio receivers

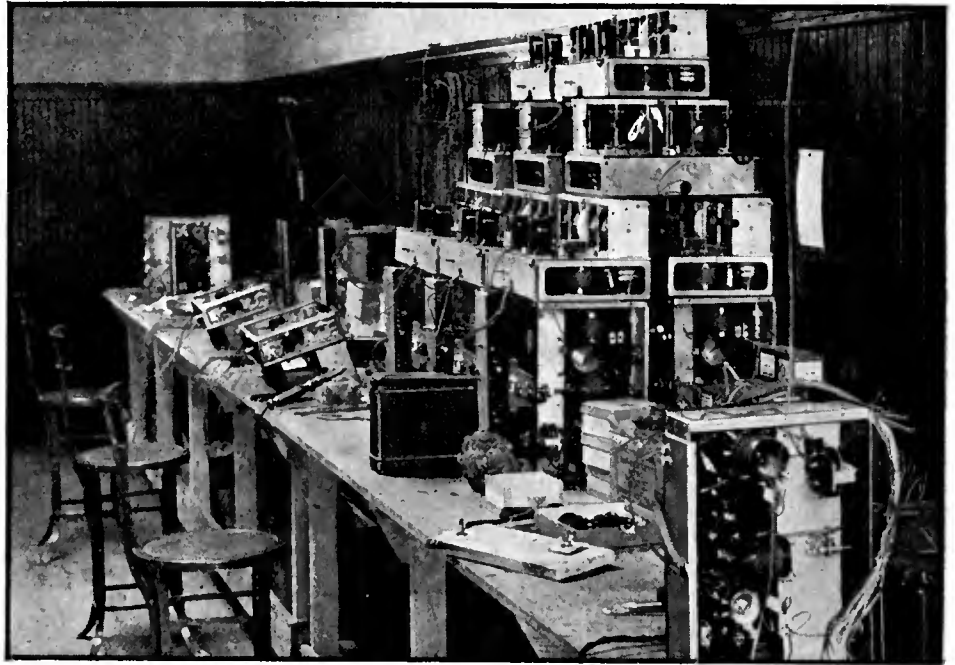

The well-arranged and equipped service department of the Electric Service Company, Inc., of Allston, Mass.

we required a method to adjust the gang condensers to resonance. A modulated oscillator and a 0-125 milliammeter across the input to the loud speaker did the trick. Each trimmer screw was adjusted to give a maximum reading on the meter.

"A fraction of a turn made a decided difference in the reading of the meter."

### Hum—Its Cause and Cure

**I**N A GENEROUS response to our request for data on hum, radio servicemen have contributed the following suggestions on this all important subject:

*Hum in dynamic speakers:* "The use of dry rectifiers in popular-priced dynamic

loud speakers has been discovered the source of hum in many instances.

"The hum which is common in a.c. dynamic loud speakers, can be eliminated almost entirely by connecting dry C batteries or flashlight batteries across the rectifier output. The positive terminal of the battery should connect to the positive side of the rectifier. As the voltage supplied to the field coil varies in different types of loud speakers, it should be measured before connecting the batteries. If no voltmeter is available, try various battery voltages, with the current turned on, until no spark is seen when the battery connection is made or broken. It is best to have the battery voltage slightly lower than the rectified output, so that no current will be drawn from the battery. A switch must be used to disconnect the battery when the loud speaker is not in use in order to prevent the battery from discharging into the rectifier. This arrangement makes a very effective filter, and is much cheaper than a low-voltage condenser."

A. H. GOUD, South Portland, Me.

*Hum from rectifier discs:* "When determining the cause of hum or extraneous noise in an a.c. outfit, if there is a dry disc metallic-type rectifier in the installation it should not be overlooked as a possible offender. The Elkon type as used on some dynamic loud speakers and A-power units seems to radiate, producing a peculiar grind which may be likened to the 'static' created by a large Tungar-type charging unit.

"In a Fada 70 receiver I traced this noise to the Elkon rectifier used on the

We like to think that RADIO BROADCAST is to the serviceman what the medical journals are to the physician. We endeavor to cover general and specific considerations involved in the servicing of all radio receivers. However, there are additional publications, in the nature of books, radio courses, and special pamphlets issued by manufacturers and other publishing sources that should not be neglected by the efficient serviceman. We review these from time to time in this department, stating specifically where they may be obtained, and the price, if any.

Fada 14b dynamic chassis. We had one set on the floor which was normal in every respect but terribly noisy, so bad, in fact, that some locals were blanketed. This is a common occurrence in our location, but in this case I 'smelled a rat.' Acting on a hunch gained through experience with Elkon trickle chargers, I disconnected the voice coil leads and plugged in a magnetic loud speaker, leaving the a.c. loud speaker leads in the circuit. The noise persisted but, on pulling out the a.c. plug to the loud speaker, it disappeared. With the dynamic chassis out of the cabinet and field coil energized, if I touched the chassis the interference was increased to a tremendous degree, making any reception impossible. This led me to believe the rectifier was producing some sort of r.f. and the metal chassis was acting as a radiator, because when I touched it, the radiating surface was increased. The remedy was evident: ground the loud speaker case. This may be accomplished with a one- or two-microfarad condenser between the case and one side of the a.c. line."

ELGIN D. MORELL, Service Radio Laboratory, East Orange, New Jersey.

**Hum from dynamic loud speaker:** "After hooking up a dynamic loud speaker with a 100-volt d.c. field to a high-grade amplifier supplying the current to this field, I was greeted with a loud deep-pitched hum. This hum seemed to be entirely in the field winding.

"After making several unsuccessful attempts to remove this hum, I hit upon a simple remedy that *entirely* eliminated it. This may prove of interest to those who are struggling with this condition, as I understand it as a common fault.

"Simply connect a 200-volt fixed condenser of from one to six microfrads across the loud speaker field. Theoretically the larger the condenser the better results. The writer used a four-microfarad unit which removed the hum to a point where it was inaudible a foot from the loud speaker, whereas without the condenser it could be heard all over the house."

E. R. HATHEWAY, Worcester, Mass.

Mr. Hatheway's experience is along the arguments adduced in the *Aerovox Research Worker*, March, 1929, which can be secured free of charge by writing to the Aerovox Wireless Corporation, 70 Washington Street, Brooklyn, N. Y. An article in this publication shows, by means of

interesting curves, how it is possible to eliminate such hum almost entirely by shunting an Aerovox 1500- or 2000-mfd. "A" condenser across the field winding. By use of high-capacity condensers it is possible to reduce the ripple level considerably below the minimum secured by hum coils.

**Reducing hum by tube shielding:** "A considerable reduction in hum can often be effected by shielding one or more of the tubes in a receiver—generally including the detector tube.

"A good many manufacturers are turning out a.c. sets in which the tubes are

**ALLEGHENY**  
**3071**  
**RADIO SERVICE**  
FRANK J. SHANNON  
5315 NAVERFORD AVE. PHILADELPHIA  
RADIOLA SPECIALIST  
AND ALL MAKES  
WORK GUARANTEED  
**KEEP THIS CARD FOR FUTURE REFERENCE**

*Original and effective! Black type on a yellow card makes this reminder easily located among the contents of the average desk drawer.*

placed adjacent to one another in a straight line. If the rectifying tube is close to any other tube, especially the detector tube, it introduces hum in the set. A very simple remedy for this trouble is to take an ordinary cylindrical baking-powder can and solder a lead to the bottom. If the can is then slipped over the rectifying tube and the lead connected to the ground post, the reduction in the hum will be gratifying."

GEORGE EARL SPEINS, Revere, Mass.

**Ballast cap reduces hum:** "In many of the modern electric sets using a heater-type detector tube (227) a bad hum will sometimes be noticed in the loud speaker. If an ordinary ballast tube cap of the type used for microphonic tubes is placed on the detector tube, and a wire from the ground attached to the cap, the hum will be found to diminish or disappear entirely."

W. GORDEN GENNER, JR., Great Neck, N. Y.

**Home-made tube ballast:** H. J. GODDARD of Ellendale, N. D., does the same thing a little more economically:

"A bad case of hum in an a.c. set that refused to respond to the usual treatment, was quieted by wrapping the 227-type detector tube with tinfoil and grounding this to the chassis."

**Miscellaneous cases of hum:** The "April installment of the 'Serviceman's Corner' discussed an interesting case of hum which recalled to my mind a similar trouble which I ran into some months ago. I was called upon to service a newly built power pack. It hummed badly, although it worked well otherwise. Apparently the circuit was connected properly as the plate, grid, and filament voltages checked correctly.

"After increasing the capacity of the detector by-pass condenser, the hum reduced materially, however, not sufficiently. It was apparent at once that something was wrong in the condenser bank. Upon careful inspection I found that the condenser bank consisted of two groups of condensers. The lead from the rectifier tube ran directly to the group of condensers which contained the detector by-pass condenser instead of first going through the choke. Thus, the hum was induced capacitatively into the detector circuit. By simply re-arranging the leads from the choke to the condenser groups the hum was eliminated."

FRED F. OERLEIN, Philadelphia, Pa.

**Poor arrangement of parts causes hum:** CHARLES H. JENKINS, JR., Radio Service, of Audubon, N. J., is both lyric and effective:

"'Hum'! How often have I heard it and how elusive it is sometimes.

"In power amplifiers where the audio system and the power-supply apparatus are on the one board or very close together you will often have a hum if the audio system is built of good transformers and the loud speaker a good dynamic cone. If the audio transformers are too near the chokes or transformer in the power supply, you will get a hum regardless of the fact that the transformers may be shielded and grounded. The greater the amplification the more likely you will hear the hum. Changing the relative positions does not help a great deal. There is only one sure answer, i.e., allow plenty of room between the power supply and the audio system.

"Another frequent cause of hum from good amplifiers that I have constructed, is the value of the grid leak. Generally speaking, a high-resistance leak in the detector circuit will permit more hum to come through than a low-value unit. Of course, the lower the resistance of the leak the less sensitive is the detector, but with sets having two or more stages of radio-frequency amplification a 1-meg. leak usually holds down the hum and does not impair the operation of the set.

"Another cause of hum is the voltage-divider system. Too low a resistance shunted across the high-voltage output places a load on the rectifying tube and causes hum."

**Hum in A-K Sets:** "The most common hum trouble that I have experienced in Atwater-Kent electric sets has been traced to a loose nut that makes connection with the common negative return to the transformer and the ground connection.

"This is one of the two screws that hold the bakelite terminal plates down to the ground connection in the transformer, choke, and condenser box, and the trouble seems to be caused by the warmth

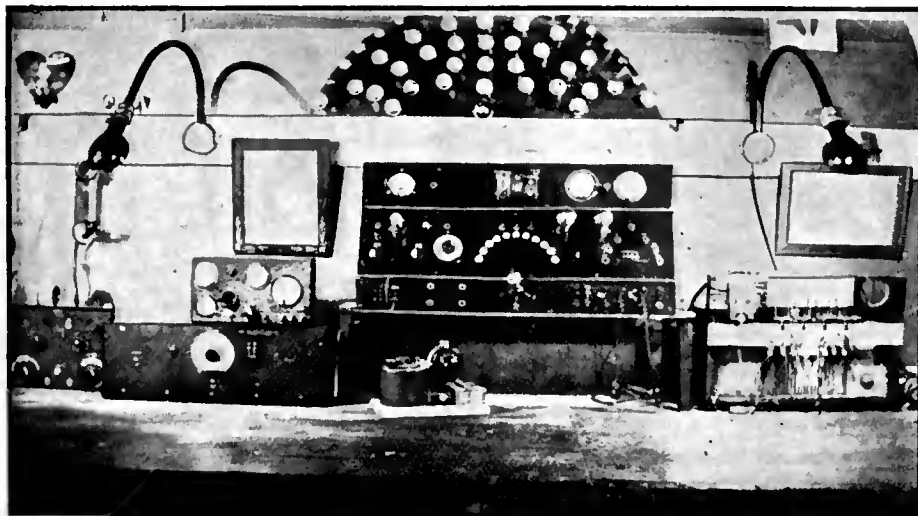

Test and service laboratory of E. F. McLaughlin, of Rockland, Mass., dealer in Atwater-Kent, Radiola, Kolster, and Majestic receivers. Prominent portions of this equipment include a modulated oscillator and a tube reactivator.



of the transformer causing the bakelite to contract enough to let the connection get loose and cause a bad hum.

"While I am at these bolts I always tighten all of the screws that hold the terminal plate of the cable down."

A. J. BARRON, Shawnee, Okla.

**Incorrect C bias:** "Just recently I serviced a home-made receiver using all a.c. tubes. When the dial was set to a place where no station could be heard the set showed no sign of any objectional hum, but as soon as a station was tuned-in there was a hum that could be heard all over the room. I happened to be able to correct this condition in a short time, because I had the same trouble on a set which I had constructed myself. The trouble was all in incorrect grid bias. When a tube has the wrong grid bias it is not being worked on the straight part of the curve, and in doing so the tube acts as a detector. This condition may often occur when a different tube is placed in the socket, the reason being that the tube is getting its grid bias by the voltage drop across a resistor, and when the plate current changes the drop across this resistor will also change and cause the wrong bias on the tube. An old tube that is losing its emission will readily show this condition to be true."

GEORGE J. WINTER, Kearny, N. J.

The C bias to all tubes except the power tube, secured by the IR drop method, can be checked with a zero to 1 milliammeter in series with a 10,000-ohm resistor, the voltage being equal to 10 times the fraction of a milliampere indicated. This, of course, is a simple application of Ohm's Law,  $E = IR$ .

**Identifying distilled water:** "Distilled water can be identified from tap water by its conductivity. Use a zero to 5 milliammeter in series with a 1½-volt

dry-cell battery and a 3000-ohm resistor. The resistor may be cut out if an original test indicates a safe deflection without it. The purer the water the higher its resistance. Good battery water should not pass more than 0.1 milliamperes."

J. P. KENNEDY, South Bend, Ind.

Items of Interest

**HAMMACHER, SCHLEMMER & Co., Inc.**, of New York City, have put together an excellent radio tool kit ("Radio Tool Kit

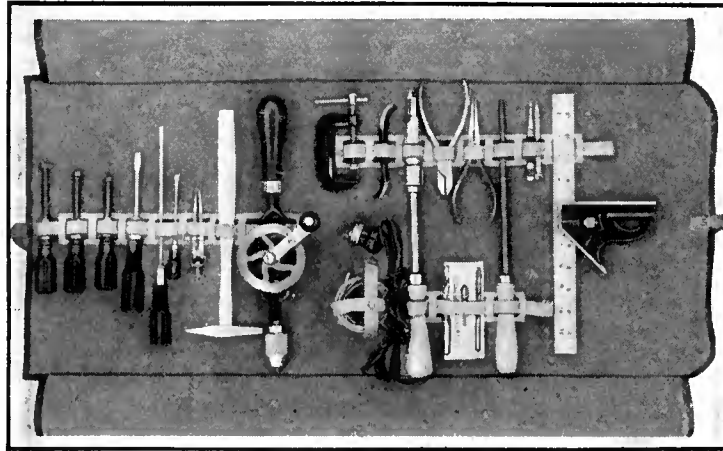

The "No. 1 Radio Tool Kit" as conceived by Hammacher-Schlemmer. A convenient outfit for the serviceman.

Number 1") selling for \$20.00. This contains all the tools the serviceman will require on the average call—from an electric soldering iron to socket wrenches—and it packs into a convenient canvas roll.

**THE KENNEDY MFG. Co.**, of Van Wert, Ohio, are featuring an interesting line of steel tool kits (without tools) several of which adapt themselves to the needs of the radio serviceman. These can be obtained in various combinations of shelves and drawers that will accommodate tools, test equipment, tubes, and spare parts. Their complete catalog can be secured for the asking.

**C. WASHBURN**, certified radiotrician, of Jacksonville, Fla., and authorized S-M service station, is a familiar contributor to readers of the "Corner." He refers the radio expert to the Sears Roebuck catalog for a tool container:

"In the search for a suitable carrying case for tools and supplies which a serviceman needs, I ran across a portable tool chest which can be procured from Sears-Roebuck Company at a cost of about \$2.75. It measures 20" x 8" x 8" and is made of wood with a thin covering of tin and brass-bound corners. It has a convenient carrying handle on the top and has a strong lock. In appearance it resembles a miniature steamer trunk. It has a sliding tray in which I carry an electric soldering iron, pliers, screw drivers, etc., and in the bottom there is room for new tubes, condensers, head-phones, and meters."

Miscellaneous Data

**RUN-DOWN B batteries:** H. B. MOULIN, of Gilman City, Mo., says, look for leaking by-pass condensers in all cases of short-lived B batteries, testing preferably with a high-resistance voltmeter. They can also be tested with phones in series with a B Battery. Completing the circuit through the condenser, a second

connection, made five seconds later, will give next to no click on a good condenser but a loud click on a poor one.

Original Advertising Cards

**FRANK J. SHANNON**, a consistent writer for this department, believes in effective mailing cards. In the following letter he tells us a few things about himself:

"As I have been at service game so long, I advertise 'all makes repaired' but emphasize Radiola Specialists, as I served one year straight as an employee of an exclusive RCA dealer and serviced only RCA models during that one year. It seems that few servicemen thoroughly understand RCA models—I suppose this is because of RCA's methods of 'Dealer-Service,' the closed policy system, and that they closely guard the distribution of their 'service data' so that none other than their dealers receive information.

"I have a total radio experience of approximately 15 or 16 years, counting back to amateur transmitting days before war—then to merchant ship operator, U. S. Navy during war, Naval Reserve, public-address work, radio serviceman, radio broadcast operator, etc.

"I am enclosing two additional cards which may interest you. The colored one is for leaving with customers—they lose the ordinary small card so quickly that I thought a contrasting colored card would be found among their papers more easily. This card may also be used as a distribution circular as it will fit into these new apartment 'locked mail box' slots. The printed government postal card is for brief communication and it serves also as a 'mail-ad.'

After Bridge - Radio Concert  
**United Electric Radio Store**  
 Unexcelled Standard.  
 SALES **RADIO** SERVICE  
 FRONT and MADISON AVENUE,  
 TELEPHONE 3366 PLAINFIELD, N. J.  
**BRIDGE SCORE**

HONORS		HONORS		HONORS	
WE	THEY	WE	THEY	WE	THEY

**ANOTHER BRIDGE PAD**  
 WILL BE FURNISHED ON REQUEST.

TRICKS ♠ TRICKS ♡ TRICKS ♣

Bridge score pads with your message printed on them constantly bring your name to the attention of customers and their friends.

RADIO SERVICE OF ALL MAKES  
**FRANK J. SHANNON**  
 RADIO ANNOUNCER - ENGINEER  
 WCAU  
 5515 HAVERFORD AVE. - PHILA. DELPHIA, PA.  
 ALLEGHENY 3071

*Frank J. Shannon*  
 P. S. More Power to You!

Making the most of the postcard. An attractive card that suggests wide-awake servicing.

# The TUBE Business



THE OPINION of George Lewis, vice-president of the Arcturus Radio Tube Company, the success of the 245-type power tube (Arcturus 145) will put a stop to the expensive clamor for higher-powered receivers. The way in which the demand for greater power output changed with time is shown in Fig. 1, and Fig. 2 gives Mr. Lewis' figures which show the relation between power output and cost of home-made B-power units. It is possible to build a 90-volt B-power unit for about \$20.00 (retail cost of parts), a 180-volt power unit for \$30.00, a 250-volt power unit for about \$45.00, and a 450-volt power unit for about \$120.00. In other words, a supply device that will furnish enough power for two 145-type power tubes in push-pull can be constructed for less than fifty dollars while a similar device for a single 250-type tube, which would furnish approximately the same undistorted power output, would cost over twice as much. "Proportionate savings will

well-known tube manufacturers about their expanding production plans, we believe that there will not be a tube shortage in 1929. According to M. F. Burns, sales manager of E. T. Cunningham, Inc., there will be ample tubes for all present and contemplated receiver sockets in 1929.

"The Cunningham organization will produce as many tubes during the first six months of 1929 as during the entire year of 1928, the banner year in the company's history. Our company delivered 61 per cent. more tubes in 1928 than in 1927, during which time production facilities were increased consistently until we were able to enter the present year with production capable of meeting demand.

"At present our personnel has been increased to 5000 employees, with factory space and equipment added to maintain full schedules. We are providing a tube supply well in excess of the trade's most optimistic estimate of the market's growth," he declared.

Readers may find other signs that there will be no dearth of tubes in the following items gathered from various sources.

A new plant has been projected for the Perryman Electric Company, Inc. It will cost \$300,000, will have a capacity of 50,000 radio and electric tubes, and will double the company's output. Unfilled orders (May 13, 1929) amounted to 2,000,000 tubes. Daily production is expected to be at the rate of 25,000 a day by September 1.

The Hygrade Lamp Company, of Salem, Mass., which produced 5000 tubes a day in May, expected to be in daily production of 10,000 tubes by the middle of July and 15,000 tubes by September 1.

Large orders on hand and demands from large set manufacturers have forced the Cable Radio Tube Corporation to add to their Brooklyn plant. The new plant is located at 80-90 No. Ninth Street, Brooklyn. The daily capacity of the Cable factories is now 25,000 tubes.

The Schickerling Radio Tube Corporation has been incorporated in Delaware to acquire the business and assets of Con-

rad Schickerling, Inc. To provide for the expansion of the company's Newark plant, the company will offer 100,000 shares of no-par-value capital stock. The principle

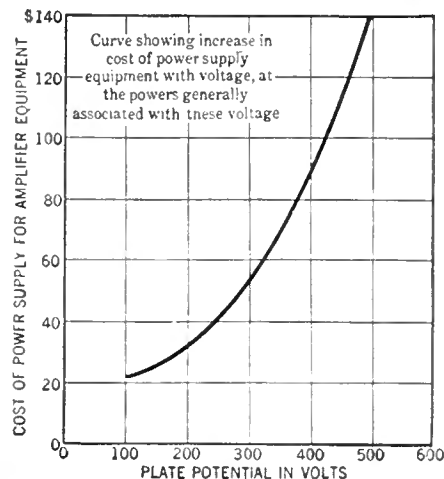

Fig. 2

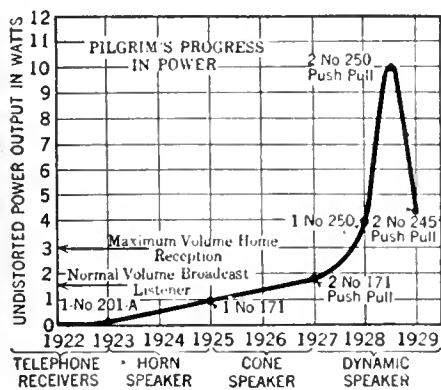

Fig. 1

be experienced by manufacturers," says Mr. Lewis.

Readers of "Strays from the Laboratory" may recall that in that department appeared Mr. Lewis' statement that the usefulness of a tube increases according to some "high-powered" function of the number of elements within the glass bulb. This statement, appearing at a time when many thought the screen-grid tube was a "dud," did not create the impression it should. Those who scoffed at the screen-grid tube will probably change their tune in 1929—this four-element tube will probably be the general-purpose tube of the next few years. Who knows but that the receiver of the future may be a three-tube set with a single stage of screen-grid r.f. amplification, a screen-grid detector, and a pentode power tube?

## No Tube Shortage in 1929

EVERYONE KNOWS that 1928 saw an enormous shortage in tubes and nearly everyone is wondering whether or not 1929 will see similar difficulty. After examining many statements from all of the

well-known tube manufacturers about their expanding production plans, we believe that there will not be a tube shortage in 1929. According to M. F. Burns, sales manager of E. T. Cunningham, Inc., there will be ample tubes for all present and contemplated receiver sockets in 1929.

"The Cunningham organization will produce as many tubes during the first six months of 1929 as during the entire year of 1928, the banner year in the company's history. Our company delivered 61 per cent. more tubes in 1928 than in 1927, during which time production facilities were increased consistently until we were able to enter the present year with production capable of meeting demand.

"At present our personnel has been increased to 5000 employees, with factory space and equipment added to maintain full schedules. We are providing a tube supply well in excess of the trade's most optimistic estimate of the market's growth," he declared.

Readers may find other signs that there will be no dearth of tubes in the following items gathered from various sources.

A new plant has been projected for the Perryman Electric Company, Inc. It will cost \$300,000, will have a capacity of 50,000 radio and electric tubes, and will double the company's output. Unfilled orders (May 13, 1929) amounted to 2,000,000 tubes. Daily production is expected to be at the rate of 25,000 a day by September 1.

The Hygrade Lamp Company, of Salem, Mass., which produced 5000 tubes a day in May, expected to be in daily production of 10,000 tubes by the middle of July and 15,000 tubes by September 1.

Large orders on hand and demands from large set manufacturers have forced the Cable Radio Tube Corporation to add to their Brooklyn plant. The new plant is located at 80-90 No. Ninth Street, Brooklyn. The daily capacity of the Cable factories is now 25,000 tubes.

The Schickerling Radio Tube Corporation has been incorporated in Delaware to acquire the business and assets of Con-

product of the company is the "Noblow" radio tube.

The CeCo Manufacturing Co., of Providence, R. I., maker of radio tubes, in a balance sheet issued as of March 31 (end of its fiscal year) shows current assets in excess of \$600,000. Cash on hand and in banks exceeds one-half million dollars; the remainder is in call loans. The ratio of current assets to current liabilities is as of 6 to 1. Patents, processes, and trademarks are carried at only one dollar.

The CeCo Manufacturing Company has just completed plant improvements costing more than \$500,000. Its new factory covering three and one-half acres will be occupied this month. It will have a capacity of 45,000 tubes daily. In addition to the Providence, R. I., plant, CeCo has purchased recently a property at 1312 South Michigan Boulevard, Chicago. It will be used as district headquarters office for the territory surrounding Chicago, and warehouse facilities will be added.

## Financial Statements of Tube Manufacturers

The data in this table have been gathered from various sources, chiefly from statements issued by the companies in question and from announcements of new stock issues—of which there are many. These figures have been obtained from sources believed to be reliable, but are not guaranteed.

TUBE MANUFACTURER	SALES	PERIOD	PROFIT	SHARES OUTSTANDING
Keu-Rad Corp., Inc.		1926	\$392,380	
		1927	315,213	
		1928	347,010	
		(First Quarter) 1929	138,675	150,000
DeForest Radio Co.	\$976,486	6 mos. ending Mar. 31, 1929	176,829	820,543
Northeru Mfg. Co.		July 1, 1928 to Jan. 31, 1929	191,072	150,000 50,000 (pref)
Arcturus Radio Co.	119,670	1927	(77,998)	
Cable Supply Co.	1,096,323	1928	93,909	600,000
Marvin Radio Co.	1,029,624	1928	92,829	200,000
Perryman		1928	263,030	146,000
		1928	207,581	250,000
		3 mos. ending Dec. 31, 1928	177,017	

# The Radio Broadcast LABORATORY INFORMATION SHEETS

By HOWARD E. RHODES

THE aim of the RADIO BROADCAST Laboratory Information Sheets is to present, in a convenient form, concise and accurate information in the field of radio and closely allied sciences. It is not the purpose of the Sheets to include only new information, but to present practical data, whether new or old, that may be of value to the experimenter, engineer, or serviceman. In order to make the Sheets easier to refer to, they are arranged so that they may be cut from the magazine and preserved, either in a blank book or on 4" x 6" filing cards. The cards should be arranged in numerical order.

Since they began, in June, 1926, the popularity of the Information Sheets has increased so greatly that it has been decided to reprint the first one hundred and ninety of them (June, 1926-May, 1928) in a single substantially bound volume. This volume, *Radio Broadcast's Data Sheets*, may now be bought on the newsstands, or from the Circulation Department, Doubleday, Doran & Company, Inc., Garden City, New York, for \$1.00. Inside each volume is a credit coupon which is worth \$1.00 toward the subscription price of this magazine. In other words, a year's subscription to RADIO BROADCAST accompanied by this \$1.00 credit coupon, gives you RADIO BROADCAST for one year for \$3.00 instead of the usual subscription price of \$4.00.

—THE EDITOR.

## Here's the Answer

# THE RADIO MANUAL

A Complete Course in  
Radio Operation  
In a Single Volume



A Handbook for  
Students  
Amateurs  
Operators  
Inspectors

For the first time an entire course of training in one book—the most complete and up-to-date work on radio. Developed simply and clearly from the elementary stage right through all phases of principles, practice, and apparatus so that a beginner with no knowledge of electricity may get all he needs either for amateur operation or to qualify for a government license as operator or inspector.

Prepared by Official  
Examining Officer

The author, **G. E. Sterling**, is Radio Inspector and Examining Officer, Radio Division, U. S. Dept. of Commerce. The book has been edited in detail by **Robert S. Kruse** for five years Technical Editor of QST, the Magazine of the Radio Relay League. Many other experts assisted them.

**16 Chapters Cover:** Elementary Electricity and Magnetism; Motors and Generators; Storage Batteries and Charging Circuits; The Vacuum Tube; Circuits Employed in Vacuum Tube Transmitters; Modulating Systems; Wavemeters; Piezo-Electric Oscillators; Wave Traps; Marine Vacuum Tube Transmitters; Radio Broadcasting Equipment; Arc Transmitters; Spark Transmitters; Commercial Radio Receivers; Radio Beacons and Direction Finders; Radio Laws and Regulations; Handling and Abstracting Traffic.

**New Information** never before available such as a complete description of the Western Electric 5 Kilowatt Broadcasting Transmitter; description and circuit diagram of Western Electric Superheterodyne Radio Receiving Outfit type 6004-C; Navy Standard 2-Kilowatt Spark Transmitter; etc., etc. Every detail up to the minute.

**Free Examination**

"The Radio Manual" has just been published. Nearly 700 pages. Profusely illustrated. Bound in Flexible Fabrikoïd. The coupon brings the volume for free examination. If you do not agree that it is the best Radio book you have seen, return it and owe nothing. If you keep it, send the price of \$6.00 within ten days.

Order on This Coupon

**D. Van Nostrand Co., Inc.,**  
8 Warren St., New York

Send me THE RADIO MANUAL for examination. Within ten days after receipt I will either return the volume or send you \$6.00, the price in full.

(Radio Broadcast 7-29)

Name.....

St. & No. ....

City and State.....

No. 288

RADIO BROADCAST Laboratory Information Sheet

July, 1929

Index

(June 1928 to May 1929)

SUBJECT	SHEET NO.	MONTH	SUBJECT	SHEET NO.	MONTH
Acoustics, Effect of	266	March	Coupling Transformers Used	251	January
A. C., r.m.s. Vs. Peak Voltage	241	December	Field Circuits of	228	October
Amplification Constant	197	June	Ear, Characteristics of	280, 281	May
Amimeters, How They Work	222	September	Effective Resistance	203	July
Audio Amplifiers:			Equalizers, Reason for Use	212, 213	August
By-pass Condensers in	252	January	Equalizing Wire Lines	207	July
Impedance-Coupled	231	October	Farm-Lighting Systems	202	July
Input Circuits of	282	May	Filament Voltages, Importance	272	March
Preventing Howling	194	June	Filter Circuits, Analysis of	258, 259	February
Preventing Distortion in Television	242, 243, 247, 248	December	Filters, Various Types	230	October
Antennas, Received Power	208	July	Galvanometers, Design of	205	July
Audio Transformers:			Graphs, Types of	264	February
Primary Inductance	227	October	Grid Bias from Power Units	275	April
High-Frequency Operation	234	November	Grid-Bias Resistances	225, 226	October
Balancing Radio Receivers	233	October	Harmonics, Power in	267	March
Band-pass Circuits, Width	255	January	Heater Connections	257	February
Bass Notes, Importance of	269	March	I-I-Q Receiver, Circuit	215, 216	August
Battery Sets, Electrification	265	March	Hum, Origin of	261	February
Books on Radio	224	September	Hum Voltage	284, 285	May
Broadcast and Short-Wave Set	238, 239	November	Impedance-Coupled Amplifiers	231	October
Capacity-Inductance Products	278, 279	May	Inductance-Capacity Products	278, 279	May
Current, Direction of Flow	199	June	Kilocycle-Wavelength Chart	263	February
Drill Sizes	219	September	Line Voltage, Effect on Tube	201, 204	July
Dynamic Loud Speakers	236	November	Measuring Instruments	214	August
Bucking Coils in	274	April	Meters, Protection of	283	May

No. 289

RADIO BROADCAST Laboratory Information Sheet

July, 1929

Index (Continued)

Milliometer, as a Voltmeter	217	September	Screen-Grid R. C. Amplifiers	195, 196	June
Motorboating, Prevention of	193	June		206	July
Neutralizing r.f. Circuits	273	April	Selectivity, R. F. Amplifier	209	August
Power Output:			Servicing Radio Receivers	218	September
Amount Required	215	December	Shielding, Use of	253	January
Effect of Impedance on Formulas for Various Tubes	256, 237	January, November	Short-Wave and Broadcast Set	238, 239	November
Operation on 220 Volts A. C.	270	March	Soldering Irons, Care of	211	August
Push-pull Amplifiers:	246	December	Tap Sizes	219	September
Preventing Howling of	241	December	Telephone Set	276, 277	April
Preventing Howling of	191	June	Telephone Transmission Units	229	October
Testing for Faults in Dual	271, 262	March, February	Television Amplifier	247, 248	December
Radio Receivers:			Television, Data on	240	November
Balancing of	233	October	Television, Frequency Band Tubes:	235	November
Servicing of	218	September	Grid Bias Resistance of A. C.	225, 226	October
Radio Transmission	223	September	Effect of Filament Voltage	254	January
Rectifier Tubes, Protection	210	August	Effect of Voltage on Life	201, 204	July
Resistance-Coupled Amplifiers:			Heater connections to A. G.	257	February
Distortion in	242, 243	December	Hum Voltage of A. C.	284, 285	May
Filter Circuits for	249, 250	January	Power Output of	246	December
Screen-Grid Tubes in	195, 196	June, July	Tuned Circuits:		
Voltage Gain of	206, 260	July, February	Effective Resistance of	203	July
Resistors, Determining Size	200	June	Mathematics of	268	March
R. F. Screen-Grid Amplifier	198	June	Voltage Gain of R. C. Amplifiers	260	February
Roberts Four-Tube A. C. Set	220, 221	September	Voltmeters, How They Work	232	October
Room Acoustics, Effect of	266	March	Voltmeter, Milliometer as a	217	September
Screen-Grid R. F. Amplifier	198	June	Wavelength-Kilocycle Chart	263	February
			Wire Lines, Equalizing	207	July

# Test them yourself

The new A. C. De Forest Audion 427 reduces hum to one thirtieth the usual value and eliminates crackle entirely.

DE FOREST RADIO CO.  
JERSEY CITY NEW JERSEY



# de Forest AUDIONS



## ROBERT S. KRUSE

Consultant and Technical Writer

103 Meadowbrook Road, West Hartford, Conn.  
Telephone Hartford 45327

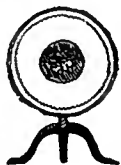

## ANTIQUES

by

Sarah M. Lockwood

Comprehensive, clear and handy, Antiques will solve your problem of getting the right furniture for the early American home.

Illustrated with 250 drawings  
\$3.50

DOUBLEDAY, DORAN



# Build Your 1929 Receiver with Approved Parts

A Complete Selection of Audio and  
Power Parts and Units



THIS year a new combination of Power and Tone Reality is available to the average radio owner at somewhat less cost than heretofore possible. This big new market of owners is attained by the introduction of the new UX-245 Tube and the accompanying Dongan Power Parts, all designed to coordinate with the remarkable tube.

Set Manufacturers and Custom Builders are invited to use the services of the Dongan Laboratories in planning their production. Prices quoted on request.

- No. 994 Power Amplifier Transformer \$12.00  
either
- No. 2189 Push-Pull Output Transformer - - - - - 12.00  
with
- No. 2142 Push-Pull Input Transformer 4.50  
or
- No. 3107 Straight Output Transformer 12.00  
with
- No. 2158 Audio Transformer - - - - 4.50  
Two Secondary Windings (for either No. 2189 or No. 3107), one for Magnetic type and the other for Dynamic type Speaker.

- D-946 Standard Condenser Unit - - 22.50  
This Condenser Unit is also designed especially for use with No. 994 Transformer for Power Amplification.

- No. 5554 Double Choke, use in Filter Circuit - - - - - 11.00

These Dongan Parts are available now. Equip your receiver with this new amplifier—and enjoy still another of Radio's greatest advancements.

### For Push-Pull Radio and Phonograph Amplifier

- No. 2124 Transformer - - - - - 6.00

Send check or money order for immediate delivery. Complete information on request.

## DONGAN ELECTRIC MANUFACTURING CO.

2991-3001 Franklin Street  
Detroit



Order your copy of *Radio Broadcast* from your news dealer or radio store. Make sure that he reserves a copy for you each month. If your favorite radio store does not stock the magazine write us giving name of radio dealer and address.

**For ANY Tube  
D.C. or A.C.**

AMPERITE automatic filament control increases tube efficiency and lengthens tube life. \$1.10 with mounting (in U. S. A.)

*Radiall Company*  
50 FRANKLIN ST., NEW YORK

FREE New "Amperite Blue Book" of latest radio information and circuit diagrams.  
Write Dept. RB-7

# AMPERITE

REG. U.S. PAT. OFF.  
The "SELF-ADJUSTING" Rheostat

## Just Off the Press

A NEW

# YAXLEY

Catalog



Send for it today for complete listings of Radio Convenience Outlets, Connector Plugs, Rheostats, Fixed and Grid Resistances, Jacks, Jack Switches, Phone Plugs, etc.

YAXLEY MFG. CO.

Dept. B, 9 So. Clinton St., Chicago, Ill.



# Sensitivity

-power-tone reproduction-unsurpassed volume-

all these and more in the



## RADIO TUBE

If you want a thrill from an extra-fine performance of your radio, install a complete set of CeCo Tubes at one time.

Users of CeCo Tubes have learned to expect exceptionally faithful reproduction of tone quality. They also know that it is not necessary to shift tubes from one socket to another in order to obtain the best reproduction their set is capable of giving—the high quality and character of CeCo Tubes are uniform.

There are 64 reasons for this. Every tube that leaves the CeCo factory is thoroughly seasoned and given 64 exacting tests for uniformity of quality and characteristics that affect successful radio reproduction. The result is not only uniformity, but much longer life as well.

If you need just one tube, try a CeCo. As the other tubes wear out, install CeCo's until you have a complete set. Then call in your neighbors and ask them if they ever heard better radio reproduction.

# CeCo

## Manufacturing Company, Inc.

PROVIDENCE, R. I.

Licensed under patents and applications of the Radio Corporation of America, the General Electric Company, and the Westinghouse Electric and Manufacturing Company.

MILLIONS IN USE

No. 290

RADIO BROADCAST Laboratory Information Sheet

July, 1929

### FILTER CIRCUIT DATA

IN "LABORATORY SHEETS" Nos. 258 and 259 some data were given on filter circuits showing the effect on the regulation, output voltage, and tube load when using and when not using a choke at the input to the filter system. Similar data will be found in Roger Wise's article "Characteristics of Power Rectifiers" in the April, 1929, RADIO BROADCAST. Several readers have written us to the effect that they have not been able to duplicate these curves when using a choke in the input. Some have obtained greater and others less output voltage than was indicated by the curves in "Laboratory Sheet" No. 259.

This discrepancy between the values we gave and that readers have obtained is undoubtedly due to the use of a different size choke coil in the input than was used to obtain the curves on Sheet No. 259. For these curves a standard filter choke of some 30 henries was used. The output voltage, of course, is greatest when there is no choke coil connected in the input and will decrease when a choke is placed at the

input. The greater the inductance of the choke, the greater the decrease in output voltage. Those experimenters who obtained greater voltages than the curves indicated probably used an input choke of low inductance and those that obtained smaller voltages used a choke of high inductance.

It could appear from these considerations that a small choke should be used but it should be remembered that the primary reason for the use of choke input circuits is to reduce the instantaneous load on the rectifier tubes so that their life will be a maximum. With chokes of low inductance this desirable effect of reduced load on the tube is not obtained to any considerable degree. In designing such systems a compromise must, therefore, be reached between the use of a large choke giving a good tube load characteristic and a small choke giving a less desirable load characteristic but greater output voltage (assuming that the transformer input voltage is not changed.)

No. 291

RADIO BROADCAST Laboratory Information Sheet

July, 1929

### VOLTAGE-DOUBLING CIRCUITS

IN CASES WHERE there is need of a plate-supply device delivering greater voltages than can ordinarily be obtained from the usual type of rectifier tube, such as the type 2B1, it is possible to use these tubes in "voltage-doubling" circuits. Two circuits together with their regulation characteristics are given on Laboratory Sheet No. 292. Although the 2B1-type rectifier in ordinary circuits can supply only about 600 volts to the filter system it should be noted that when using these special circuits it is possible to obtain an input to the filter of approximately 1600 volts.

The circuit shown at A is probably the more familiar type of voltage-doubling connection. As indicated by the curves the voltage regulation is rather poor but, when only small amounts of current are to be drawn from the system, this circuit can be used and has the advantage that it requires but little apparatus.

Improved results can be obtained from the circuit shown at B. With this arrangement four rectifier tubes are used in a full-wave system supplied from a center-tapped transformer having a secondary potential of from 500 to 700 volts a.c. either side of the center tap. Two separate transformers, each supplying from 500 to 700 volts might, of course, be used. The curves

for this rectifier system show it to have much better regulation than that obtained from the circuit in Sketch A. With circuit B a maximum current of up to 170 milliamperes can be drawn from the filter system.

The disadvantage of circuit B over circuit A is that the former requires three separate filament windings each of which must provide the full output voltage.

The first filter condensers in these circuits must be capable of withstanding a potential of one half the load voltage. The second condensers must, of course, be able to withstand the full load voltage. The filaments of the tubes should be turned on before the high-voltage winding is closed. If this is not done, the initial charging current may overheat the tubes or cause them to arc over. Across the output of the filter systems resistors should be connected as indicated at R. In general a 100,000-ohm resistor may be used and it should be capable of carrying some 20 milliamperes. This resistor is especially necessary when using circuit A since, with this arrangement, the voltage tends to increase quite rapidly when the load is less than 20 milliamperes.

The data for this "Laboratory Sheet" were supplied by E. T. Cunningham, Inc.

No. 292

RADIO BROADCAST Laboratory Information Sheet

July, 1929

### VOLTAGE-DOUBLING CIRCUITS

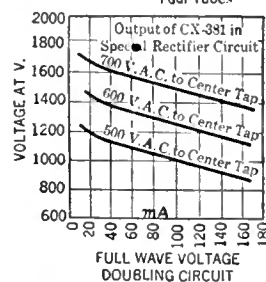
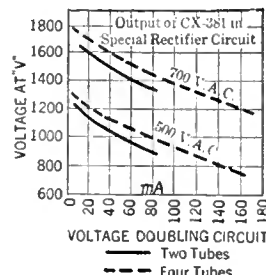
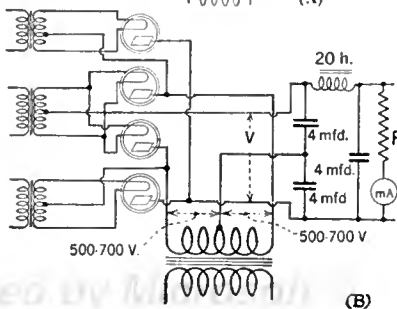
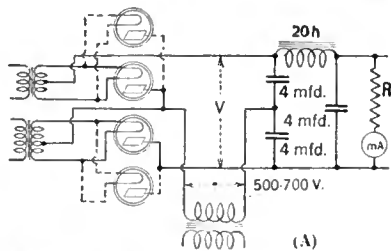



*Off the DEEP END*  
Christopher Morley

... "No one doubts the amazing vivacity and facility of Christopher Morley ... 'Off The Deep End,' like several of its predecessors is a collection of stray pieces, short stories, brief playlets, humorous squibs and Lambian essays. The reader saunters, so to speak, through Mr. Morley's engaging purlieus admiring the gusts of the greenery, the sparkling quality of the streamlet of wit and the whimsicality of the curious growths"—*New York Times*.

... "Whatever he does will be fascinating talk ... talk which makes his book of essays a pleasant adventure"—*New York Evening Post*.

... Other books by Christopher Morley. THE ROMANY STAIN, WHERE THE BLUE BEGINS, THUNDER ON THE LEFT and THE HAUNTED BOOKSHOP.



**DOUBLEDAY DORAN & COMPANY, INC.**  
Garden City, New York  
\$2.50 at all bookshops

# A RADIO RECEIVER IS LIKE A CHAIN....

A CHAIN of parts, if you please . . . transformers, tubes, condensers, resistances and the like as links of the chain. Unless each link performs to perfection the whole receiver is condemned and your name with it.

A lot of grief can be traced to one little part . . . the volume control. Noises are set up . . . unevenness of control develops . . . locals are hard to handle.

You can save yourself plenty of trouble by seeing that the name "Centralab" is stamped on the volume control. The Centralab exclusive rocking disc construction prevents any change in the resistance or the development of noise. Centralab controls give a perfect control of all stations with an even, "velvety" smooth action.

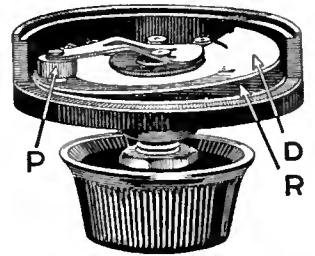

This shows the exclusive rocking disc construction of Centralab volume control. "R" is the resistance. Contact disc "D" has only a rocking action on the resistance. Pressure arm "P" together with shaft and bushing is fully insulated.



This is the action of the usual wire wound control after it has been in use for some time . . . like dragging a stick over a cobblesone pavement.



The tailor uses the same principle as Centralab. He does not want to ruin the garment by placing the iron on it so he places a cloth in between. Centralab controls cannot ruin the resistance because the rocking disc is in between the pressure arm and the resistance.

## Centralab

CENTRAL RADIO LABORATORIES  
20 Keefe Ave. Milwaukee, Wis.

### AERO-CALL

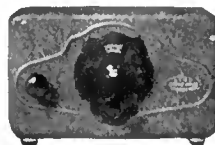

Factory-Built, Ready to Plug Into Any Set  
Shielded—Filtered  
No Motorboating

This amazing instrument now makes it possible to reach 'round the world. Geo. Morcroft of Pa. tuned in England, Australia and Holland on his initial test. Gets stations regular receivers cannot get. No change or wiring required. All complete, ready to operate. Golden brown, compact metal cabinet in crackle finish. Size 9x5 1/2 x 2 1/2 in. The only converter we know of that really works on all sets. Two models—A.C. and D.C., at \$25.00 each. Write for Catalog and literature and dealers' discounts; also give jobbers' name.

#### Send for Aero Short Wave Guide

Gives the very latest details on Aero Coils and Kits, Short Wave Radio, newest broadcast radio receivers, short wave converters, telephone transmitters, coil kits, adapters and a host of new wrinkles for 1929. The kits everyone is talking about are fully described. Chronophase, Metropolitan, Trio, International, Standard, Radiophone—in Shield Grid, A.C. and D.C. models—all good summer sellers. Be sure to send for your copy—worth \$25.00 to anyone who wants to keep up with the latest radio wrinkles. Mail coupon for your copy today—now!

### AERO PRODUCTS INCORPORATED

4611 E. Ravenswood Ave., Dept. 279, Chicago, Ill.

MAIL THIS COUPON NOW

AERO PRODUCTS Inc.  
4611 E. Ravenswood Ave., Dept. 279, Chicago, Ill.  
Send me your Short Wave Guide, giving the latest information on what's new in radio, short wave, etc. to help me boost my summer sales.  
Name.....  
St. & No.....  
City..... State.....

## Cunningham RADIO TUBES

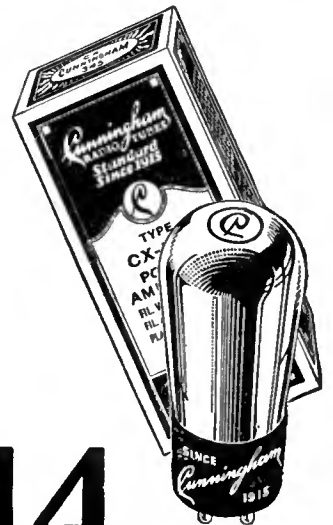

**14** years of proved reliability

Cunningham Radio Tubes continue to supply the demand for absolute inbuilt integrity and tube quality.

**E. T. CUNNINGHAM, Inc.**  
New York Chicago San Francisco  
Dallas Atlanta



Model No. 102  
A massive walnut cabinet equipped with automatic phonograph and an improved radio receiver.

**Steinite**  
ELECTRIC-RADIO

**Only DURHAMS**  
are good enough for  
*this Great Receiver!*

ANY manufacturer can cut his parts costs, but it takes leadership to aim at quality reception as a means of winning a quality market, such as Steinite has done in a few short years. Steinite operates on the principle that you can get out of a radio only what you put into it. And so Steinite means a quality circuit embracing every practical modern idea, not the least of which is DURHAM Resistors and Powerohms—the metallized resistances which are endorsed and used by leaders in every division of the industry. Durhams may cost a trifle more than average resistances, but experience has proved that their slight additional cost is cheap insurance against imperfect performance and against dissatisfied purchasers. Ask Steinite! We shall be glad to send engineering data sheets and samples for testing upon request. Please state ratings in which you are interested.

*Metallized*



DURHAM Metallized RESISTORS and POWEROHMS are available for every practical resistance purpose in radio and television circuits, 500 to 200,000 ohms in power types; 1 to 100 Megohms in resistor types; ratings for all limited power requirements; standard, pigtail, or special tips.

THE LEADERS STANDARDIZE ON

**DURHAM**  
METALLIZED

**RESISTORS & POWEROHMS**

INTERNATIONAL RESISTANCE CO.  
2006 Chestnut Street, Philadelphia, Pa.

No. 293

RADIO BROADCAST Laboratory Information Sheet

July, 1929

REGENERATIVE R. F. AMPLIFIERS

RADIO-FREQUENCY amplification may be obtained by the use of carefully designed r.f. circuits or by the use of carelessly designed circuits with regeneration. Many of the sets made a few seasons ago had considerable inherent regeneration in them, not because circuits to prevent regeneration were not known, but because the sets were not properly designed. The tendency to-day is to design the set so that without any regeneration the gain and selectivity are satisfactory. If an engineer relies on regeneration in a receiver to give it gain, it is generally found that in the mass production of the set in the factory it is not possible to control the set's characteristics closely enough to give just the right amount of regenerative amplification. As a result in production some of the sets will be found to oscillate while others will not have sufficient regeneration and will be practically dead. This is perhaps one of the major reasons why regeneration is being used less and less in manufactured sets.

There is one time, however, when the use of regeneration to increase the gain and the selectivity might be considered the best thing to do. This case arises in the servicing of an old receiver that has poor gain and poor selectivity. Such a set would be improved greatly by the use of some regeneration, and, since the service-

man who changes the circuit to give it some regeneration can introduce just enough in this particular set to provide satisfactory performance, there is little difficulty involved in its use.

Regeneration can be added most readily to an existing receiver by the use of one of the circuits indicated on Laboratory Sheet No. 294.

In Sketch A regeneration has been added by winding a coil (No. 32 or smaller wire) around the filament end of the secondary,  $L_1$ . The number of turns should be the maximum that can be used without causing the set to oscillate.

In Sketch B a small variable condenser,  $C_1$ —for example, a neutralizing condenser—is connected between the plate of the detector and the plate of the preceding r.f. amplifier tube. The capacity should be adjusted to the maximum possible without making the detector oscillate.

In Sketch C regeneration is secured by tapping the secondary,  $L_1$ , as indicated and connecting a small variable condenser (maximum capacity about 0.0001 mfd.) between the lower end of the secondary and the plate of the detector.

Arrangement B is generally the most convenient although in some cases it may be simpler to use the circuits of A or C.

No. 294

RADIO BROADCAST Laboratory Information Sheet

July, 1929

REGENERATIVE R. F. CIRCUITS

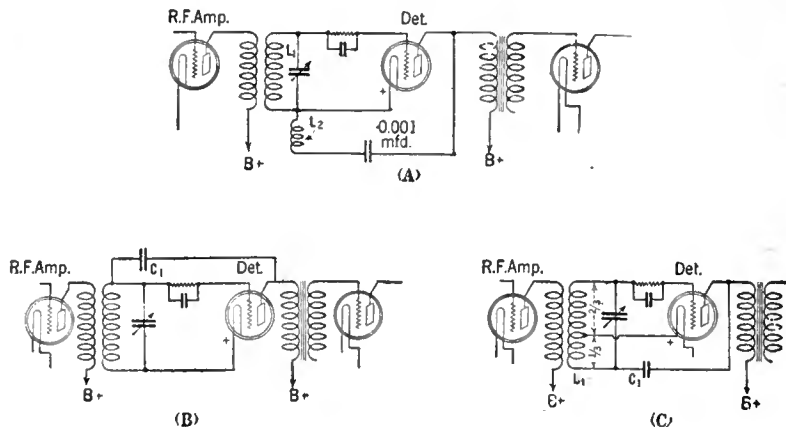

No. 295

RADIO BROADCAST Laboratory Information Sheet

July, 1929

TUBE-TESTING CIRCUITS

MANY COMMERCIAL tube-testing devices are equipped with a button which is used to determine whether or not the particular tube being tested is up to standard. Generally the procedure is to place the tube in the socket, read the plate current, then press the button, and again read the plate current. Then it is possible to determine from these two readings whether or not the tube is any good.

Just how this circuit functions should be of interest. The arrangement described below may not be the one actually used in some of the testers but the principles are certainly the same. When a tube is placed in the socket (see the sketch A on this sheet) the plate current as read on the plate milliammeter depends upon the plate voltage and upon the C-bias voltage. With the switch, S, which represents the button, in the open position, the bias is equal to the voltage of the C battery. When, however, the button is pressed the bias is reduced to zero. This change in bias, of course, produces a change in plate current and the amount of change determines how good the tube is. What

we are actually doing is determining the mutual conductance of the tube by noting the change in plate current obtained from a given change in C bias.

This circuit, it should be pointed out, indicates only one of the many possible arrangements. Another arrangement, for example, would be to make S a single-pole double-circuit switch (sketch B) so that in one position the bias is zero and in the other position it has a value equal to that of the C-battery voltage.

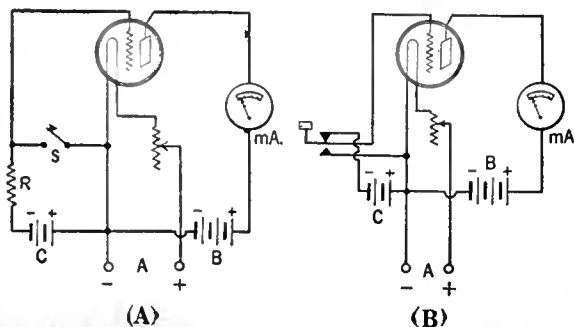

QUALITY RAW MATERIAL \*  
ADVANCED LABORATORY  
IMPROVE-  
MENTS \*

WE  
PUT THIS INTO  
THE TUBE

MODERN \* \*  
\* FACTORY  
TECHNIQUE  
MONEY \* \*  
\* TIME \* \*  
ORGANIZATION  
\* \* THOUGHT  
CRAFTSMANSHIP  
\* \* ENERGY \*  
\* BRAINS \* \*  
EXPERIENCE \*



UNIFORM  
\* \* QUALITY  
\* \* TONE \*  
PERFECTION \*  
\* FINER \* \*  
REPRODUCTION  
LONGER LIFE \*  
REASONABLE  
\* \* PRICES \* \*

A COMPLETE \*  
\* LINE \* \* \*  
A QUALITY LINE \*  
AN ADVERTISED  
\* LINE \* \* \*  
\* CONSUMER \*  
\* \* \* DEMAND \*

QUICK TURNOVER \* LIBERAL  
DISCOUNTS \* LARGE PROFITS

# SPEED

CABLE RADIO TUBE CORPORATION

(formerly Cable Supply Co.)

84-90 N. Ninth St., Brooklyn, N. Y.

MAKERS OF RADIO TUBES SINCE 1924







## *Sylvania Announces*

# THE SILENT SLEEVE CATHODE

The pioneering courage and exhaustive experimentation that always have been part of Sylvania development, again bear fruit. This time in the silent sleeve cathode which definitely solves the long baffling problem of crackle and hum in the 227 tube.

The Sylvania 227 now minimizes hum and further increases amplification as a result of the Sylvania designed sleeve which extends over the entire length of the heating element.

The same kind of diligent research and intelligent application of discoveries account for the superior performance found in all types of Sylvania tubes.

We will be glad to send you bulletins showing the characteristics and advantages of all Sylvania tubes.

### **SYLVANIA PRODUCTS COMPANY**

Emporium

Pennsylvania

# *Sylvania* **RADIO TUBES**

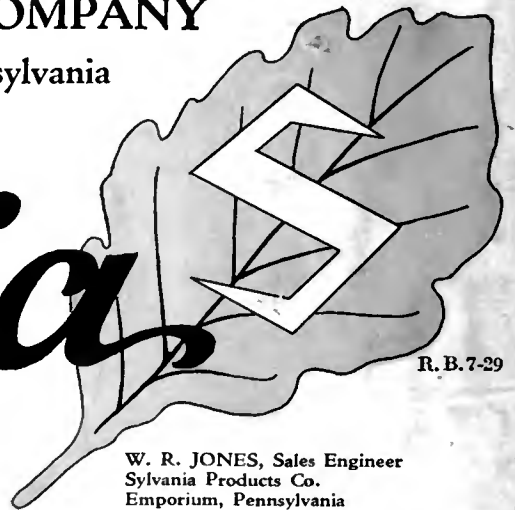

R. B. 7-29

W. R. JONES, Sales Engineer  
Sylvania Products Co.  
Emporium, Pennsylvania

Please send me bulletins showing characteristics of your humless 227. Also bulletins on the following other types:

For Further Information  
Please Use the Coupon  
**YOU'RE WELCOME!**

Name.....  
Company.....  
Position.....  
Address.....  
City and State.....